

# Miniature Ball Screw Assemblies Single Nut with Flange

The Drive & Control Company



# Ball Screw Assemblies

## Product Overview

### Miniature Ball Screw Assemblies

**Miniature Ball Screws are available from stock as complete assemblies with flanged nuts.**

The prefabricated end machining makes an easy combination with the fixed bearing (support block with bearing) LGL possible as a complete package.

The load capacity of the support bearing is critical. By friction welding the bearing journal we were able to enlarge smaller screw diameters and increase load capacity.

This can simplify the choices for many customer specific positioning and transport applications.

The construction and ordering process for new applications can also be handled more effectively.

Every nut comes pre-assembled with clearance and seals.

### End Bearing LGL

The end bearing LGL with angular contact ball bearing in an "X" arrangement makes an ideal accessory.

- High load capacity
- Very easy mounting with the flanged housing
- Corrosion resistant housing
- Seals provide protection from contaminants
- Simple preload of the fixed bearing
- Maintenance free for most applications due to the large lubricant reservoir with initial greasing

Economical turnkey solutions made easy.

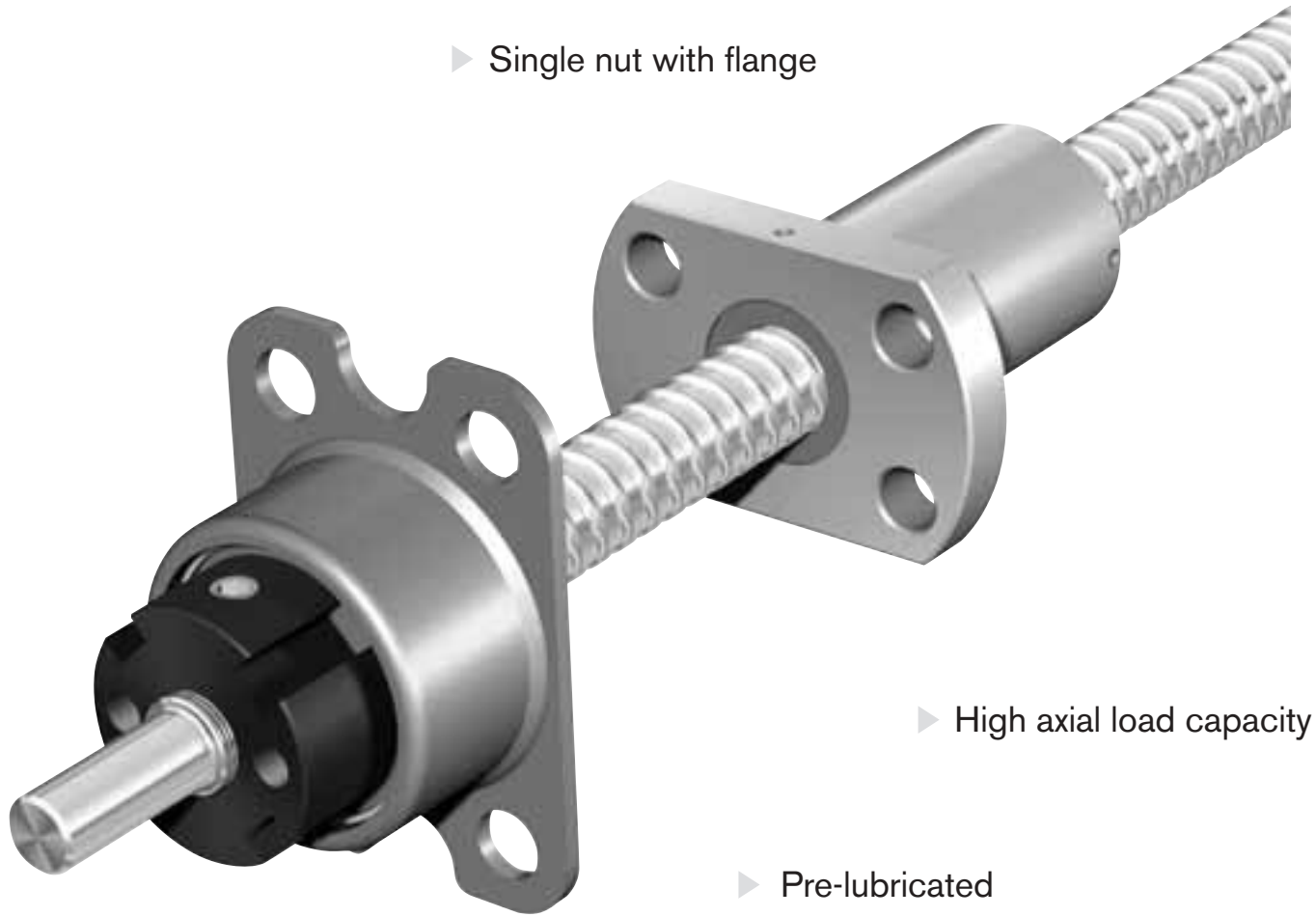

▶ Single nut with flange

▶ High axial load capacity

▶ Pre-lubricated

▶ Bearing and slotted nut optional

▶ From stock

# Ball Screw Assemblies

## Miniature Ball Screw Assemblies with Single Nut with Flange

### Miniature Line

Single Nut with Flange FEM-E-B with Rexroth mounting dimensions

With Seals

With backlash or reduced backlash  
Screw tolerance class T7

$d$  = Nominal diameter

$P$  = Lead  
(R = Right, L = Left)

$D_w$  = Ball diameter

$i$  = No. of turns

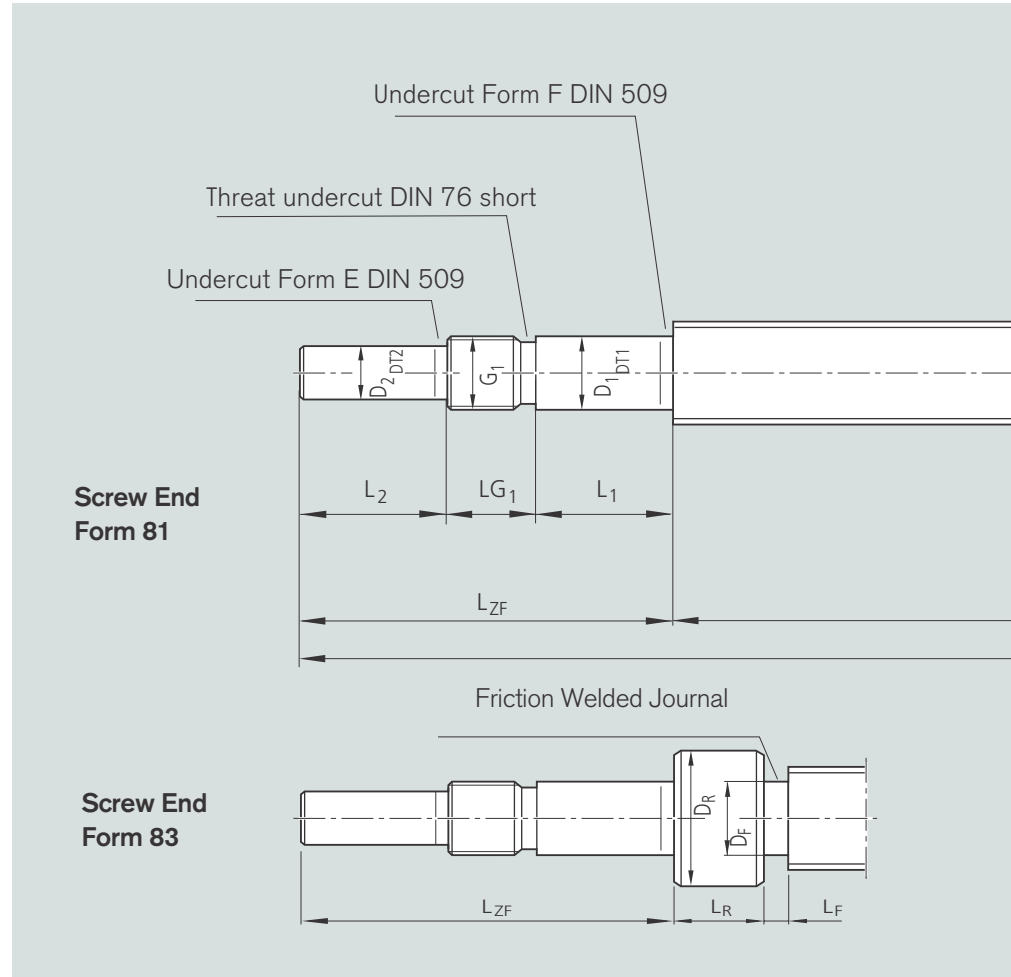

Size $d_0 \times P \times D_w - i$	Part No.	Basic load rating		Max. Speed $v_{max}$ [m/min]	$L_{Ges}$	$L_{Gew}$	
		dyn. C (N)	stat. $C_0$ (N)				
6 x 1 R x 0,8-4	1530-1-0040	900	1290	3	255	191	
6 x 2 R x 0,8-4	1530-1-0041	890	1280	6	255	191	
8 x 1 R x 0,8-4	1530-2-0720	1020	1740	3	355	291	
8 x 2 R x 1,2-4	1530-2-0721	1870	2760	6	355	291	
8 x 2,5R x 1,588-3	1530-2-0722	2200	2800	15	355	291	
12 x 2 R x 1,2-4	1530-4-1090	2240	4160	12	400	359	
12 x 5 R x 2-3	1530-4-1091	3800	5800	30	400	359	
12 x 10 R x 2-2	1530-4-1092	2500	3600	60	400	359	

### Ordering Codes

FEM-E-B	6x1Rx0,8-4	1	1	T7	R	83K061	00K060	255	0	1
FEM-E-B	6x2Rx0,8-4	1	1	T7	R	83K061	00K060	255	0	1
FEM-E-B	8x1Rx0,8-4	1	1	T7	R	83K062	00K080	355	0	1
FEM-E-B	8x2Rx1,2-4	1	1	T7	R	83K063	00K080	355	0	1
FEM-E-B	8x2,5Rx1,588-3	1	1	T7	R	83K064	00K080	355	0	1
FEM-E-B	12x2Rx1,2-4	1	1	T7	R	81K061	00K120	400	0	1
FEM-E-B	12x5Rx2-3	1	1	T7	R	81K061	00K120	400	0	1
FEM-E-B	12x10Rx2-2	1	1	T7	R	81K061	00K120	400	0	1

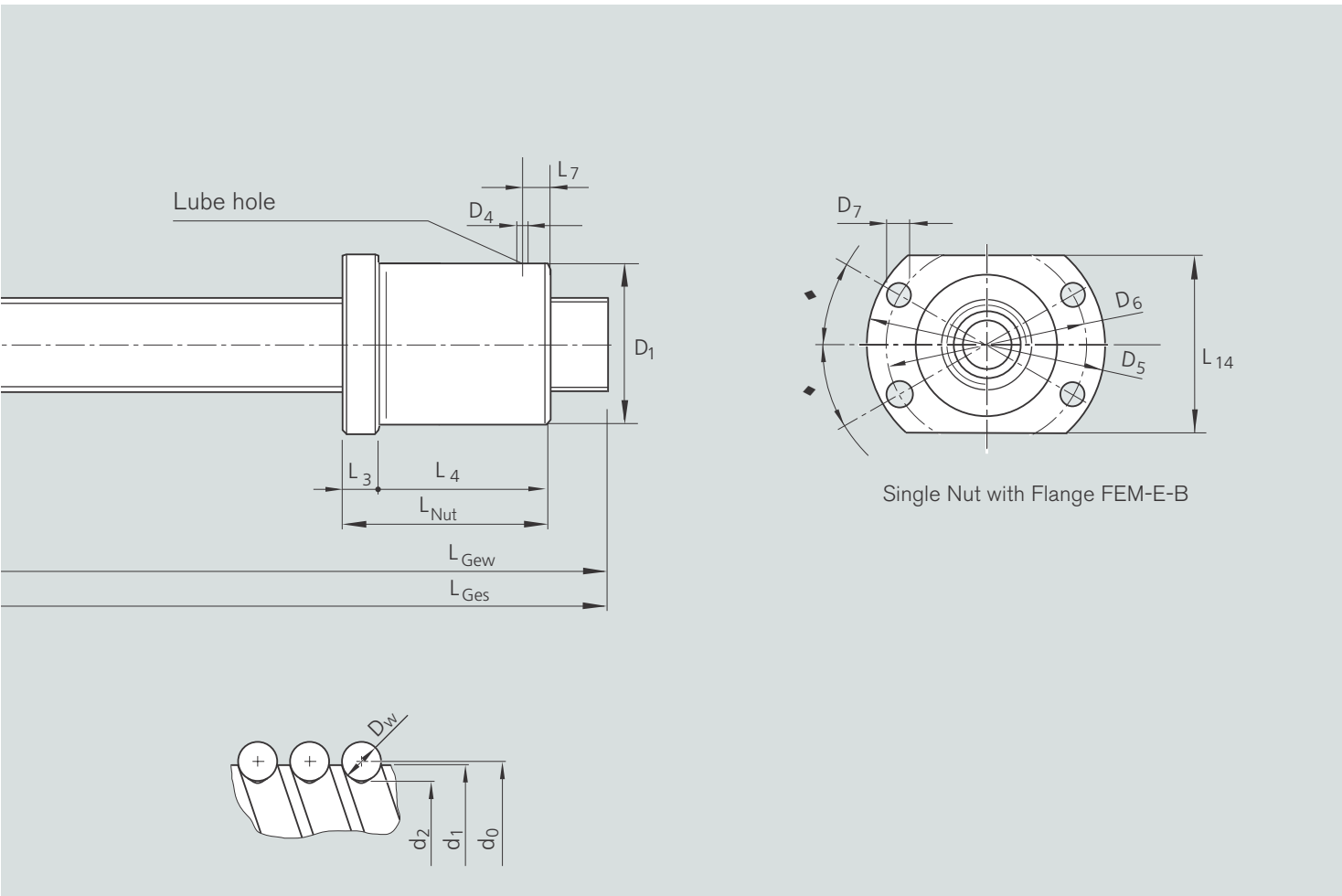

Nut Dimensions (mm)												Backlash (mm)
D <sub>1</sub> g6	D <sub>4</sub>	D <sub>5</sub>	D <sub>6</sub>	D <sub>7</sub>	L	L <sub>3</sub>	L <sub>4</sub>	L <sub>7</sub>	L <sub>14</sub>	◆ (°)		
12	2	24	18	3,4	19,5	3,5	16	3,5	16	30	0,01	
12	2	24	18	3,4	22,5	3,5	19	3	16	30	0,01	
16	2	28	22	3,4	22	6	16	3,5	19	30	0,01	
16	2	28	22	3,4	25	6	19	3	19	30	0,01	
16	2	28	22	3,4	16	6	10	3	19	30	0,01	
20	2	37	29	4,5	19	8	11	2,5	24	30	0,01	
22	2	37	29	4,5	28	8	20	6	24	30	0,01	
20	2	37	29	4,5	33	8	25	8	24	30	0,01	

Size		Form	Version	Screw Dimensions (mm)															
d <sub>0</sub>	P			d <sub>1</sub>	d <sub>2</sub>	L <sub>ZF</sub>	D <sub>R</sub>	L <sub>R</sub>	D <sub>F</sub>	L <sub>F</sub>	D <sub>1</sub>	DT1	L <sub>1</sub>	D <sub>2</sub>	DT2	L <sub>2</sub>	G <sub>1</sub>	LG <sub>1</sub>	
6	1		061	6	5,3	41	12	15	5,2	8	6	h6	10	5	h7	16	M6x0,5	15	
6	2		061	6	5,3	41	12	15	5,2	8	6	h6	10	5	h7	16	M6x0,5	15	
8	1		062	8	7,3	41	12	15	7,2	8	6	h6	10	5	h7	16	M6x0,5	15	
8	2		063	8	7,0	41	12	15	6,9	8	6	h6	10	5	h7	16	M6x0,5	15	
8	2,5		064	7,5	6,3	41	12	15	6,2	8	6	h6	10	5	h7	16	M6x0,5	15	
12	2		061	11,7	6,9	41	-	-	-	-	6	h6	10	5	h7	16	M6x0,5	15	
12	5		061	11,4	9,9	41	-	-	-	-	6	h6	10	5	h7	16	M6x0,5	15	
12	10		061	11,4	9,9	41	-	-	-	-	6	h6	10	5	h7	16	M6x0,5	15	

# Ball Screw Assemblies

## Bearing LGL

Fixed bearing with angular-contact thrust ball bearing LGL

Suitable for screw end forms on page 4

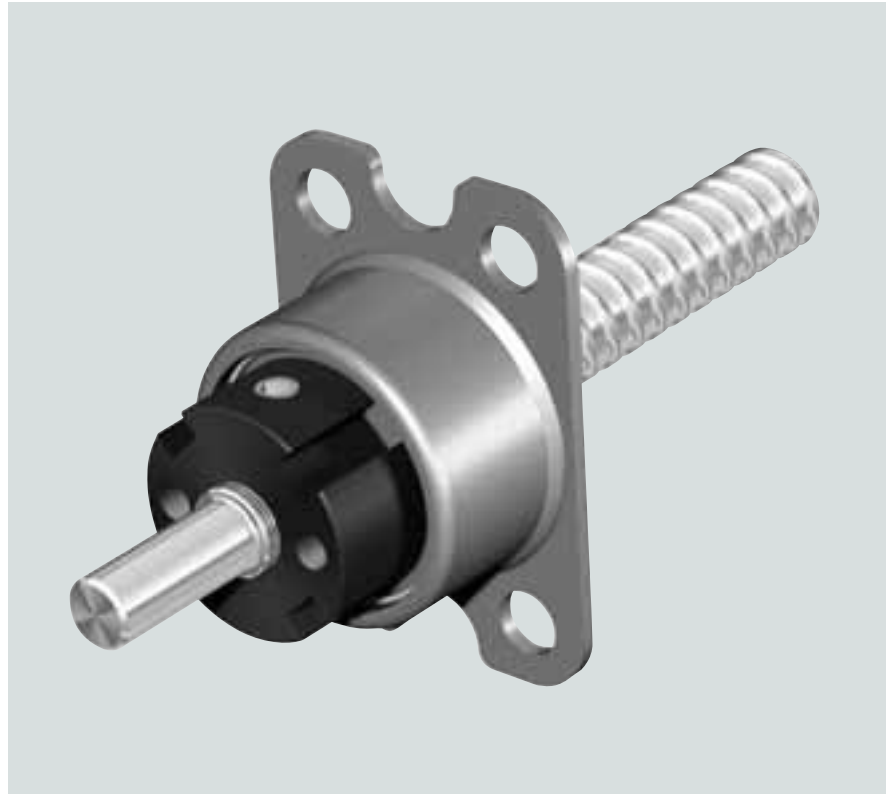

Size	Angular-contact thrust ball bearing				Slotted Nut	
	Part number	Designation	Load ratings (axial)		Designation	Part number
dyn. C (N)			stat. C <sub>0</sub> (N)			
d <sub>o</sub> x P						
6x1/2	8414-038-06	LGL-D-0624	1340	1250	NMG 6x0,5	8446-010-02
8x1/2/2,5	8414-038-06	LGL-D-0624	1340	1250	NMG 6x0,5	8446-010-02
12x2/5/10	8414-038-06	LGL-D-0624	1340	1250	NMG 6x0,5	8446-010-02

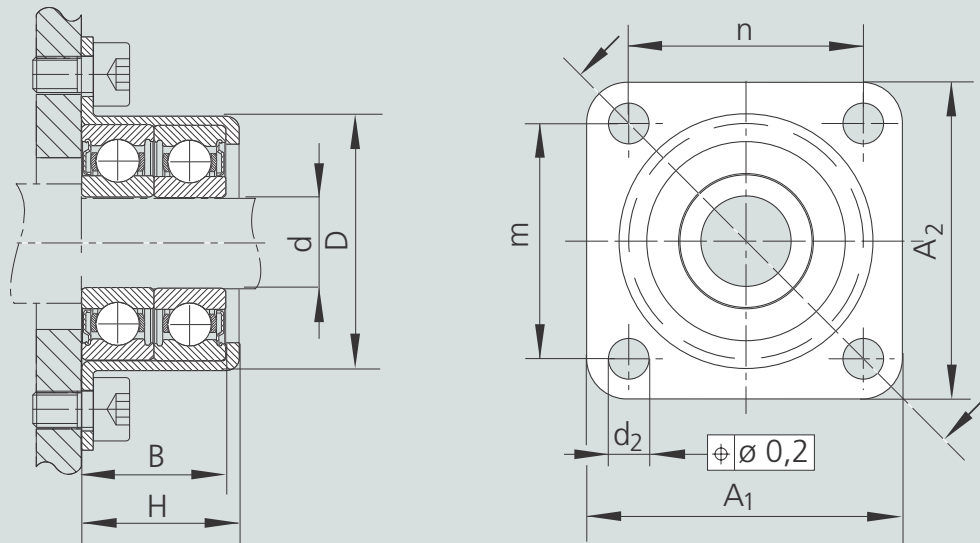

Dimensions (mm)										Weight bearing
d	D +0,03 -0,01	A <sub>1</sub>	A <sub>2</sub>	n	m	H	B	d <sub>2</sub>		(kg)
6	20,5	24	35	15	26	13	-0,25 12	4,5		0,023
6	20,5	24	35	15	26	13	12	4,5		0,023
6	20,5	24	35	15	26	13	12	4,5		0,023

# Ball Screw Assemblies

## Acceptable Conditions and Tolerance Grades

### Permissible travel deviation

similar to DIN 69 051, Part 3 and ISO 3408-3

### Symbol definitions

- $l$  = Nominal travel
- $l_1$  = Thread length
- $l_e$  = Excess travel
- $l_u$  = Useful travel
- $c$  = Travel compensation for useful travel, defined by use (standard:  $c=0$ )

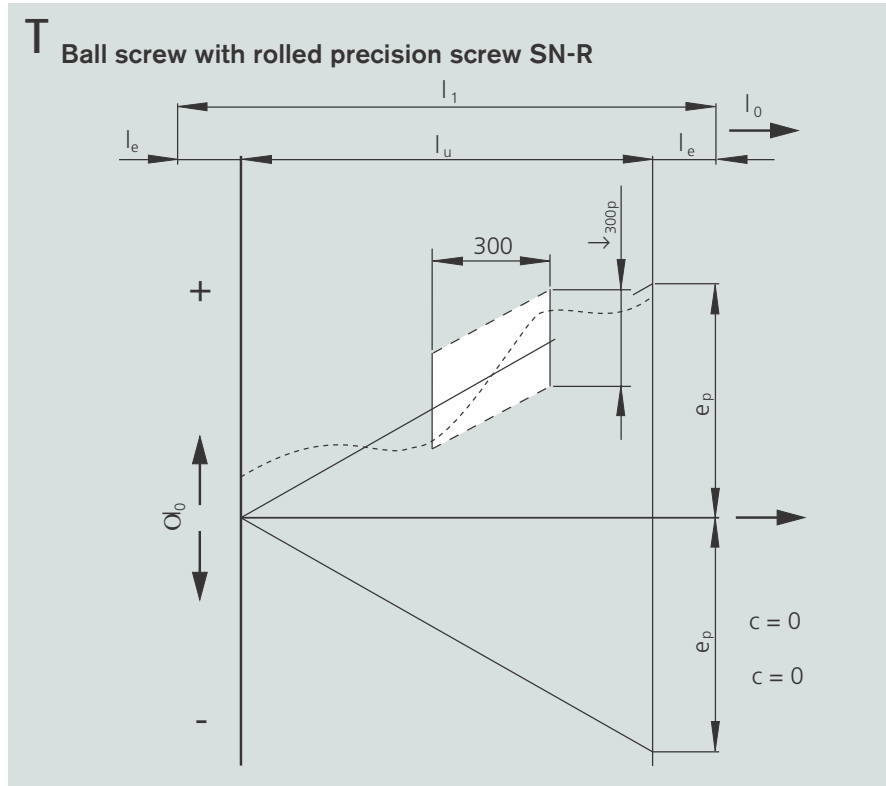

$e_p$  = tolerance for actual mean travel deviation

$\downarrow_{up}$  = permissible travel variation within useful travel  $l_u$

$\downarrow_p$  = permissible travel deviation within 300 mm travel

$\downarrow_{ep}$  = permissible travel deviation within 1 revolution

$l_u$	$e_p$ ( $\mu\text{m}$ )					
	Tolerance grade					
>	A	1	3	5	7	9
0	100	-	8	18	44	110
100	200	-	10	20	48	130
200	315	6	12	23	52	150
315	400	7	13	25	57	170

Minimum number of measurements within 300 mm (measuring interval) and permissible excess travel.

Subindices:

- $p$  = permissible
- $a$  = actual

Lead P	Min. no measurements for tolerance grades					Excess Travel $l_{e\text{max}}$ (mm)
	1	3	5	7	9	
2,5	30	20	10	5	5	10
5	15	10	6	3	3	20
10	10	5	3	1	1	40
16	8	5	3	1	1	50
20	5	5	3	1	1	60
25	4	4	3	1	1	70
32	3	3	2	1	1	80
40	-	2	1	1	1	100

# Run-outs and Location Deviations

Based on DIN 69 051, Part 3 and ISO 3408-3

Radial run out  $t_5$  of the outer diameter of the ball screw shaft over the length  $l_5$  used to determine the straightness in relation to  $AA'$

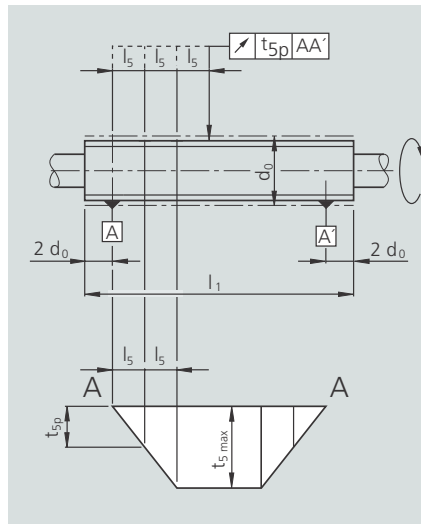

d	l	$t_p$ in $\mu\text{m}$ for I				
		for Tolerance grade				
above	up to					
= 6	12	80	20	25	32	40
12	25	160	20	25	32	40

l	d	$t_{max}$ in $\mu\text{m}$ for I B I			
		Tolerance grade			
above	up to				
	40	40	50	64	80
40	60	60	75	96	120

Radial run out  $t_6$  of the bearing diameter in relation to  $AA'$

Where  $l_6 > l$  then  $t_{6a} \leq t_6 \cdot \frac{l_{6a}}{l}$

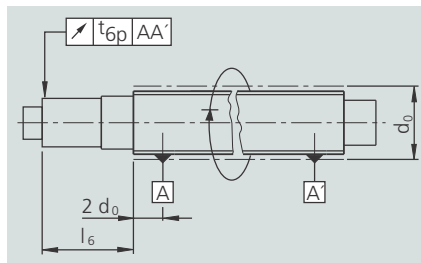

Nominal diameter d	length l	$t_p$ in $\mu\text{m}$ for I A I			
		Tolerance grade			
above	up to				
= 6	20	80	10	12	20

Coaxial deviation  $t_7$  of the journal diameter of the ball screw shaft in relation to the bearing diameter for I A I

Where  $l_7 > l$  then  $t_{7a} \leq t_7 \cdot \frac{l_{7a}}{l}$

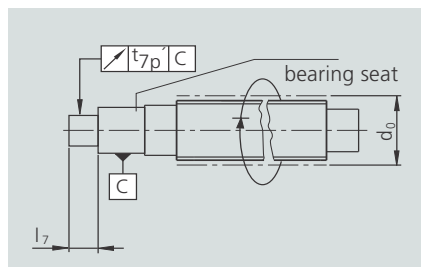

Nominal diameter d	length Ref length l	$t_p$ in $\mu\text{m}$ for I A I			
		Tolerance grade			
above	up to				
= 6	20	80	5	5	6

Axial run out  $t_8$  of the shaft bearing face of the ball screw shaft in relation to the bearing diameter

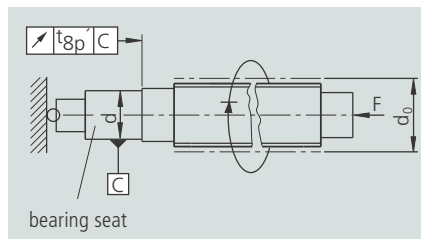

Nominal diameter d	über above	bis up to	$t_p$ in $\mu\text{m}$ for Tolerance grade		
= 6	63		3	4	5

Axial run out  $t_9$  of the ball nut location face in relation to A and A' for preloaded ball nuts only

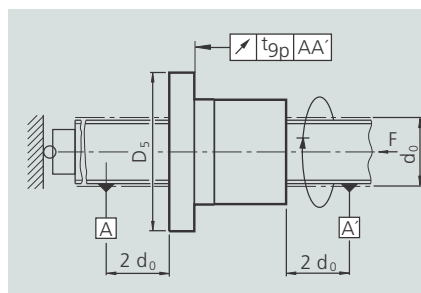

Flange diameter D	über above	bis up to	$t_p$ in $\mu\text{m}$ for Tolerance grade		
16	32		10	12	16
32	63		12	16	20

Radial run out  $t_{10}$  of the outer diameter D of the ball nut in relation to A and A' for preloaded and rotating ball nuts only. Fix screw against rotation

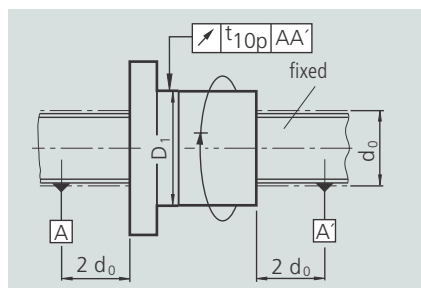

Outer diameter D	above	up to	$t_p$ in $\mu\text{m}$ for tolerance grade		
16	32		10	12	16
32	63		12	16	20

# Ball Screw Assemblies

## Preload and Rigidity Single nut

Size $d_o \times P \times D_w - i$	Load ratings		Backlash of Single nut		Stiffness of the Screw $R_s$ $\frac{N \cdot m}{\mu m}$
	dyn. C (N)	stat. C <sub>0</sub> (N)	Standard	Reduced	
6 x 1R x 0,8 - 4	900	1290	0,01	0	5
6 x 2R x 0,8 - 4	890	1280	0,01	0	5
8 x 1R x 0,8 - 4	1020	1740	0,01	0	9
8 x 2R x 1,2 - 4	1870	2760	0,01	0	9
8 x 2,5R x 1,588 - 3	2200	2800	0,02	0,010	8
12 x 2R x 1,2 - 4	2240	4160	0,01	0	21
12 x 5R x 2 - 3	3800	5800	0,02	0,010	18
12 x 10R x 2 - 2	2500	3600	0,02	0,010	18

Dynamic drag torque, preload  
and rigidity for screws with  
miniature single nut

- T = overall dynamic drag torque
- T = T<sub>pr0</sub> + T<sub>RD</sub>
- C = basic dynamic load rating
- C = basic static load rating
- T<sub>RD</sub> = dynamic drag torque of 2 seals
- R<sub>S</sub> = rigidity of the screw
- R<sub>nu</sub> = rigidity of the nut
- T<sub>pr</sub> = dynamic drag torque without a seal

- d = Nominal diameter
- P = Lead (R = Right, L = Left)
- D<sub>w</sub> = Ball Diameter
- i = No. of Turns

Size $d_o \times P \times D_w - i$	Dynamic drag torque of 2 seals
	T <sub>RD</sub> ca. (Nm) Standard seal
6 x 1R x 0,8 - 4	0,010
6 x 2R x 0,8 - 4	0,010
8 x 1R x 0,8 - 4	0,010
8 x 2R x 1,2 - 4	0,020
8 x 2,5R x 1,588 - 3	0,015
12 x 2R x 1,2 - 4	0,030
12 x 5R x 2 - 3	0,030
12 x 10R x 2 - 2	0,030

# Relubrication

## Quantities and Intervals

The nut must be lubricated with lubricant via the lube port prior to operation.

### Oil Lubrication

d <sub>o</sub>	Initial lubrication oil V <sub>e</sub> (ml)	Relubrication oil V <sub>n</sub> (ml)/10h	Revolutions U M io M ill	Travel (km) with lead P =						
				5	10	16	20	25	32	40
6	0,300	0,030	1,3	7	13	21	26	33	42	52
8	0,300	0,030	1,3	7	13	21	26	33	42	52
12	0,300	0,030	1,3	7	13	21	26	33	42	52

### Relubrication intervals for NLGI resp Greases

Size d <sub>o</sub> x P x D <sub>w</sub> -i	Relubrication quantity of grease g
	FEM-E-B Miniature
6 x 1R x 0,8- 4	0,06
6 x 2R x 0,8- 4	0,12
8 x 1R x 0,8- 4	0,12
8 x 2R x 1,2- 4	0,24
8 x 2,5R x 1,588- 3	0,10
12 x 2R x 1,2- 4	0,15
12 x 5R x 2- 3	0,30
12 x 10R x 2- 2	0,30

Bosch Rexroth Corporation  
Linear Motion and  
Assembly Technologies  
14001 South Lakes Drive  
Charlotte, NC 28273  
Telephone (800) 438-5983  
Facsimile (704) 583-0523  
[www.boschrexroth-us.com](http://www.boschrexroth-us.com)

Bosch Rexroth Corporation  
Corporate Headquarters  
5150 Prairie Stone Parkway  
Hoffman Estates, IL 60192-3707  
Telephone (847) 645-3600  
Facsimile (847) 645-6201

Bosch Rexroth Corporation  
Industrial Hydraulics  
2315 City Line Road  
Bethlehem, PA 18017-2131  
Telephone (610) 694-8300  
Facsimile (610) 694-8467

Bosch Rexroth Corporation  
Electric Drives and Controls  
5150 Prairie Stone Parkway  
Hoffman Estates, IL 60192-3707  
Telephone (847) 645-3600  
Facsimile (847) 645-6201

Bosch Rexroth Corporation  
Pneumatics  
1953 Mercer Road  
Lexington, KY 40511-1021  
Telephone (859) 254-8031  
Facsimile (859) 281-3491

Bosch Rexroth Corporation  
Mobile Hydraulics  
1700 Old Mansfield Road  
Wooster, OH 44691-0394  
Telephone (330) 263-3300  
Facsimile (330) 263-3333