

# Lubrication Guide

The Drive and Control Company



# Linear Motion Technology

## Ball Rail Systems

Standard Ball Rail Systems  
Ball Rail Systems with Aluminum Runner Blocks  
Super Ball Rail Systems  
Wide Ball Rail Systems

---

Miniature Ball Rail Systems  
Cam Roller Guides

## Roller Rail Systems

### Linear Bushing and Shafts

Linear Bushings  
Linear Sets  
Shafts  
Shaft Support Rails  
Shaft Support Blocks

---

Ball Transfer Units  
Other Engineering Components

## Screw Drives

### Linear Motion Systems

Linear Motion Slides

- Ball Screw Drive
- Toothed Belt Drive

Linear Modules

- Ball Screw Drive
- Toothed Belt Drive
- Rack and Pinion Drive
- Pneumatic Drive
- Linear Motor

Compact Modules

- Ball Screw Drive

Precision Modules

- Ball Screw Drive

Ball Rail Tables

- Ball Screw Drive
- Linear Motor

---

Controllers, Motors, Electrical Accessories  
Linear Actuators

# Lubrication Guide

<b>About this Guide</b>	<b>4</b>
<b>Initial Lubrication, Relubrication</b>	<b>4</b>
<b>Lubricant Supply</b>	<b>5</b>
<b>Lubricant Operating Conditions</b>	<b>6</b>
<b>Selection Table</b>	<b>9</b>
<b>Suitable Lubricants</b>	<b>10</b>
<b>Applicable DIN Standards</b>	<b>22</b>
– Codes for Lubricants According to DIN 51502	22
– K, KP, KF and KPF Lubricants According to DIN 51825	24
– C, CL, CL and CGLP Lubricants According to DIN 51517	24
– HL, HLP and HLVP Hydraulic Oils According to DIN 51524	25
– ISO Viscosity Classification for Oil Lubricants According to DIN 51519	26
<b>Addresses of Lubricant Manufacturers</b>	<b>27</b>

# Lubrication Guide

## About this Guide

The reliable operation of linear motion elements depends on selecting the right lubricants for the particular conditions of use.

A lubricant has to

- reduce friction and wear
- provide protection from corrosion and soiling.

Lubricant has a decisive impact on the operation and service life of linear guides. A shortage of lubricant or the use of an unsuitable lubricant are often the cause of linear guide failure.

The choice of suitable lubricants requires careful consideration during the design, operation and servicing of linear guides. It depends above all on the **operating temperature range** and the **environmental and operating conditions** at the point of use. Consideration must also be given to the type of **lubricant supply**.

Most linear motion elements work with grease or oil lubrication. Oil/air lubrication is used in some cases.

This Lubrication Guide is generally valid for all STAR products. No distinction is made, therefore, between models or types.

The guide is designed to provide you with fast help in choosing a suitable lubricant for your application.

STAR products can be provided with an initial supply of lubricant to ensure their smooth start-up. It is essential to ensure that these products are relubricated with a medium that is compatible with the initial lubricant.

## Initial Lubrication, Relubrication

Our initial lubricant and preservatives are chemically compatible with mineral oil and PAO (polyalphaolefin).

The thickening agents in our grease lubricants can be lithium, calcium or aluminum base saponification agents.

# Lubricant Supply

## Front Lube Units from Rexroth Star

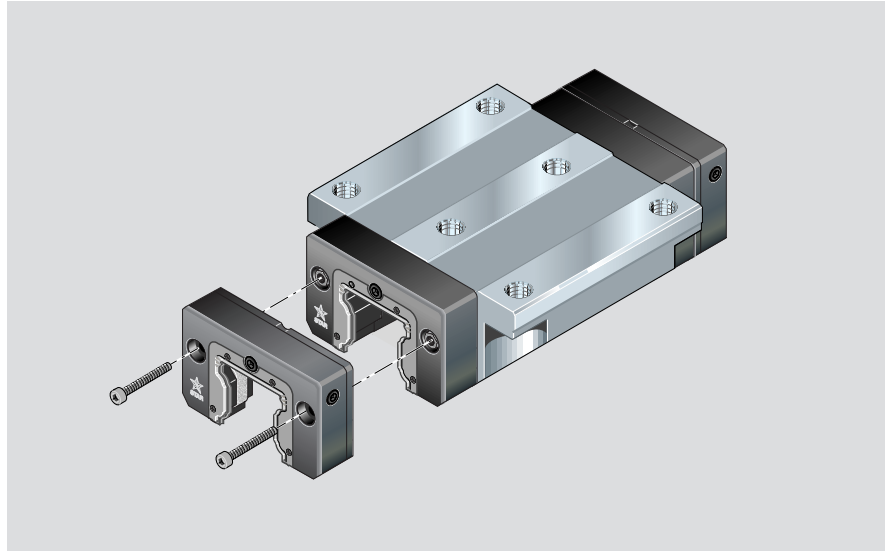

The maintenance-free operation of ball and roller rail systems is possible under favorable conditions with the use of front lube units from Rexroth STAR. Front lube units form an optimal seal between the guide rail and the runner block, which is filled with grease lubricant. They themselves work with oil lubrication and have an oil reservoir to replace oil losses.

## Seal Functions

Under favorable conditions the fine-tuned system ensures that a film of lubricant remains on the guide rail. Where dirt is a factor, there has to be a change of priority. In this case the seals are required to keep the dirt on the outside and the lubricant on the inside as far as possible.

## Grease Lubricant

Through their firm consistency, grease lubricants help to prevent dirt getting into the linear guide and promote the action of sealing and wiping elements. Grease lubricants exert an enduring and defined effect at the point of contact between the friction partners and permit long relubrication intervals, including life-long lubrication. The thickening agents used in grease lubricants also create certain emergency running characteristics.

## Grease Lubricant from a Central Lubrication System

Central lubrication systems often use liquid greases which, because of their soft fluid structure, can be distributed far better than grease grades of higher viscosity. The consistency of some liquid greases makes them unsuitable for conveyance in central lubrication systems. Consideration must be given to the geometric conditions of the central lubrication system (DIN 24271) as well as to the consistency class.

## Oil Lubricants

Oil lubricants can be distributed more evenly than greases and are better able therefore to reach the points of contact. They are also good at removing frictional heat. It should be noted, however, that oil lubricants tend to collect by force of gravity at the bottom of equipment and escape more easily than grease lubricants.

## Oil/Air Lubrication, Oil Mist Lubrication

Oil/air or oil mist lubrication is used for special applications. Oil/air lubrication causes less environmental pollution.

# Lubrication Guide

## Lubricant Operating Conditions

### Operating Temperature Range

By far the majority of applications takes place at quite „normal“ operating temperatures from +10°C to +35°C. This temperature range is covered without difficulty by conventional standard greases on a mineral oil basis with lithium saponification.

For applications in the high temperature range up to +100°C or in the low temperature down to -40°C (where the products themselves must first be checked for temperature resistance) it may be necessary to use special grease lubricants.

An operating temperature range is quoted for each grease lubricant, specifying the temperature limits between which it develops its assured characteristics to the full. Grease lubricant manufacturers use test methods and empirical values to determine the operating temperature range.

The maximal operating temperature of grease lubricants largely depends on the thickening agent used as well as on the base oil. Each thickening agent has a defined melting point. The melting point is the temperature at which, under test conditions, a grease lubricant achieves a specific viscosity and drips out of the tester. In practice the maximal operating temperature should be between +40°C and +60°C lower than the melting point.

The minimal operating temperature of grease lubricants depends above all on the viscosity of the base oil. Generally speaking, the lower the viscosity of the base oil, the lower the minimal operating temperature. Synthetic base oils are at an advantage in this respect over mineral base oils. Base oils with viscosity < 100 mm<sup>2</sup>/s at +40°C are often used for grease lubricants in the low-temperature range.

When oil lubricants are used, the selected product has to build up a lubricating film of sufficient bearing capacity throughout the temperature range, i.e. its viscosity must not become too low when heated or too high when cooled. Viscosity/temperature diagrams show the relationship between viscosity and temperature.

### Loads from Vibrations, Short Strokes and Oscillations

Machinery and equipment are often affected by high vibration frequencies, permanently oscillating movements or short strokes. The results are oscillating sliding and rotating movements at the points of contact, which destroy the lubricating film.

Key lubricant selection parameters are: rotary speed, vibratory load, stroke travel, loading forces and other environmental and operating conditions.

### High Mechanical-Dynamic Loads

High mechanical-dynamic loads require grease lubricants with extreme pressure characteristics. Grease lubricants of this type are identified by a „P“ as the second digit in the code according to DIN 51502, e.g. **KP 2 K-30**.

The suitability of the grease lubricant is determined in special tests (e.g. with a four-ball tester) designed to establish the capacity of the grease to absorb pressure and provide protection from wear. Solid lubricants such as molybdenum sulfide and graphite are often used to increase pressure absorption and prevent wear. They reduce wear in the start-up phase and in emergency running situations. **There is a risk, however, of molybdenum sulfide and graphite forming irregular deposits on antifriction bearings and rail guides. These irregularities may result in local concentrations of stress on the rolling elements and hence in premature failure.** Greases with a basic viscosity > 220 mm<sup>2</sup>/s at +40°C are often used in the heavy load range.

When oil lubricants are used instead of grease lubricants, preference should be given to high-viscosity products of at least 680 mm<sup>2</sup>/s. It is imperative for these products to have CLP rating, i.e. enhanced load capacity.

## Use in Clean Rooms

If grease lubricants are to be used under clean-room conditions it is important to ensure that there are no emissions from the grease lubricants selected. Normally this can be assumed to be the case with all grease lubricants within their permissible operating temperature range.

For clean-room applications special attention must be paid to providing adequate sealing of the lubrication points.

## Use in Vacuum

Special lubricants with extremely low rates of evaporation have been developed for applications in vacuum. The production of high-vacuum greases uses only specially pre-treated raw materials whose vapor pressure cannot have a negative effect even in the highest vacuum.

## Use in the Food Industry

Lubricants used in the production, processing and packing of food may only contain recipe components which are harmless and do not change either the taste or the smell of the food.

In Europe there is no institute which issues special permits for the food industry. Individual approvals for use are issued e.g. by the German Water and Gas Association (**DVGW**), the Bavarian State Office of Trading (**LGA**) and the Weihenstephan Engineering Test Institute (**BPVA**). In the USA, on the other hand, there are two different permits issued by the United States Department of Agriculture (**USDA**): USDA H1 and USDA H2 are both recognized in Germany.

### UDA H1 Permit

This permit is issued for lubricants whose contact with food is occasional and cannot be prevented for technical reasons.

To qualify for this permit, lubricants must contain only raw materials which meet the requirements of the American Food and Drug Administration (**FDA**). These requirements are set out in special approval lists.

### USDA H2 Permit

This permit is issued for lubricants which have no direct contact with food. To qualify, lubricants must contain none of the raw materials on the negative list drawn up by the **FDA**.

EU Directive 93/43/EEC has been in force in Europe since 1996, and the new Food Hygiene Regulation since February 1998. Both require adequate safety measures to be taken in each company to guarantee the safety of food and to combat health hazards. The practical feasibility of this safety system is based on an analysis and assessment of the risks and assumes the use of certain hygiene testing and monitoring methods (HACCP concept).

For the greatest assurance users should select lubricants whose safety can be verified by relevant approvals (DVGW, LGA, USDA H1, USDA H2).

# Lubrication Guide

## Lubricant Operating Conditions

### Use in conjunction with

- aqueous media
- diluted acids, alkalis or saline solutions

Grease lubricants are exposed in practice to environmental influences such as:

- spray water
- condensation water
- coolants
- cleaning agents
- acids and alkalis
- saline solutions
- corrosion-promoting substances

Grease lubricants saponified with calcium or a calcium complex are regarded as particularly resistant to water. Good resistance is also displayed by grease lubricants with lithium saponification. Resistance to spray water is examined in standardized tests.

Resistance to coolants and cleaning agents should be tested from case to case. Grease lubricants saponified with a calcium complex display good resistance to diluted acids and alkalis. It is recommendable, however, to carry out a separate test for each case of application.

The corrosion-preventing characteristics of grease lubricants are tested under near-operating conditions. This entails filling the bearing case of two pendulating ball bearings with a defined quantity of distilled water or artificial sea water, after which a 7-day test cycle (8 hours running, 16 hours standstill) is performed at  $80 \text{ min}^{-1}$ . At the end of the test the outer rings of the test bearings are examined for signs of corrosion.

For applications likely to be accompanied by corrosion phenomena it is best to resort to grease lubricants which have scored good marks in this test.

With few exceptions, oil lubricants are unsuitable for these applications.

# Selection Table

## How to find the right lubricant for your application:

- First consult the table along side.
- Search in the table for the **operating temperature range** and the **environmental and operating conditions** <sup>1)</sup> which apply to your case of application.
- A cross-reference **➡** points you to the page containing further details of lubricants for your application.

The addresses of lubricant manufacturers are listed on page 27.

Operating temperature range	Environmental and operating <sup>1)</sup> conditions	Suitable lubricant
<b>Normal temperature +10°C bis +35°C</b>	Dry, relative humidity 35 to 70%	➡ page 10
	Damp, relative humidity 70 to 100%	➡ page 11
	Loaded by vibrations, short strokes, oscillations	➡ page 12
	High mechanical-dynamic loads	➡ page 13
	Clean room / vacuum	➡ page 14
	Food industry USDA H1 requirements USDA H2 requirements	➡ page 15 ➡ page 16
	Aqueous Media	➡ page 17
	Diluted acids, alkalis, saline solutions (max. 10% solutions)	➡ page 18
<b>High temperature up to +100°C</b>	Dry, relative humidity 35 to 70%, Damp, relative humidity 70 to 100%	➡ page 19 ➡ page 20
<b>Low temperature down to -40°C</b>	Dry, relative humidity 35 to 70%	➡ page 21

1) These environmental and operating conditions apply providing there are no extreme dust deposits (e.g. stone dust, wood sanding dust). If there are such desposits, it will be necessary to introduce special design measures. Please inquire.

# Lubrication Guide

## Suitable Lubricants

Normal temperature +10°C bis +35°C

Environmental and operating conditions: Dry, relative humidity 35 to 70%

### Examples

Automatic assembly machines  
Transport systems

### Suitable lubricants

#### Grease lubricants

Manufacturer	Name	Specification
Agip	Longtime Grease 2	KPE 2 N-40
Aral	Aralub HLP 2	KP 2 K-30
BP	Energrease LS-EP 2	KP 2 K-20
DEA	Glissando R EP 2 LF	KGKP 2 K-30
Esso	Beacon EP 2	KP 2 N-20
Fuchs-DEA	Renolit MP	KP 2 K-40
Klüber	Centoplex 2	KP 2 K-20
Mobil	Mobilux EP 2	KP 2 K-20
Optimol	Longtime PD 2	KP 2 N-40
Shell	Alvania G2	KP 2 N-20
Tribol	Tribol 3030/100	KP 2 K-30

#### Liquid greases

Manufacturer	Name	Specification
Aral	Aralub GFP 000	GP 000 K-30
BP	Energrease PR-EP 00	GLP 00 G-30
Esso	Grease TCL 435	GP 00/000 K-50
Fuchs-DEA	Renolit LZR 000	KP 000 K-40
Klüber	Microlube GB 00	KP 00/000 N-20
Mobil	Mobilux EP 004	GP 00 G-20
Optimol	Longtime PD 00	KP 00 N-30
Tribol	Tribol 3020/1000	GP 00 K-40

#### Oil lubricants

Manufacturer	Name	Specification
Agip	Blasia 220	Minimum requirements: CLP to DIN 51517  Viscosity ISO VG 220 to DIN 51519
Aral	Degol BG 220	
BP	Energol GR-XP 220	
DEA	Falcon CLP 220	
Esso	Spartan EP 220	
Fuchs-DEA	Renolin CLP 220	
Klüber	Klüberoil GEM 1-220	
Mobil	Mobilgear 630	
Optimol	Optigear BM 220	
Tribol	Tribol 1100/220	

Normal temperature +10°C to +35°C

Environmental and operating conditions: Damp, relative humidity 70 to 100%

Examples

Cleaning system feed zone  
Machine tools

Suitable lubricants

Grease lubricants

Manufacturer	Name	Specification
Agip	Longtime Grease 2	KPE 2N-40
Aral	Aralub HLP 2	KP 2 K-30
BP	Energrease LC 2	KP 2 P-25
DEA	Spectron FO 20 EP	KP 2 N-30
Fuchs-DEA	Renolit CX-EP 2	KP 2 K-30
Klüber	Isoflex NCA 15	KP 2 K-40
Mobil	Mobilgrease XHP 222	KP2 N-20
Mobil	Mobilplex 47	
Optimol	Olista Longtime 2	KP 2 N-30
Shell	Aldida RL 2	KP 2 N-20
Tribol	Tribol 4020/220-2	KP 2 N-30

Liquid greases

Manufacturer	Name	Specification
Aral	Aralub GFP 000	GP 00 K-30
BP	Energrease PR-EP 00	GLP 00 G-30
Fuchs-DEA	SF 7-041	KP 000 K-30
Klüber	Microlube GB 00	KP 00N-20
Mobil	Mobilux EP 004	GP 00 G-20
Optimol	Olit CLS 0	KP 0 G-40
Tribol	Tribol 3020/1000-00	GP 00K-40

Oil lubricants

Manufacturer	Name	Specification
Agip	Exidia 220	Minimum requirements: CLP to DIN 51517 Viscosity ISO VG 220 to DIN 51519
Aral	Degol BG 220	
DEA	Trion EP 220	
Esso	Spartan Synthetic EP 220	
Klüber	Klübersynth EG 4-220	
Mobil	Mobilgear XMP 220	
Optimol	Optileb GT 220	
Tripol	Molub-Alloy 90/220	

# Lubrication Guide

## Suitable Lubricants

Normal temperature +10°C to +35°C

Environmental and operating conditions: Loads from vibrations, short strokes, oscillations

### Examples

Printing presses, forming systems, clamping systems, centering devices  
Plastic injection molding machines

### Suitable lubricants

#### Grease lubricants

Manufacturer	Name	Specification
Agip	Autol Top 2000	KP 2 G-30
Aral	Aralub 4034	KP 2 K-20
Aral	Aralub MKL 2	KP 2 K-20
BP	Energrease LC 2	KP 2 P-25
Esso	Beacon EP 1	KP 1 K-30
Klüber	Microlube GL 261	KP 1 N-30
Mobil	Mobilgrease XHP 222	KP 2 N-20
Optimol	Longtime PD 2	KP 2 N-30
Tribol	Tribol 3020/1000-2	KP 2 K-30

#### Liquid greases

Manufacturer	Name	Specification
Aral	Aralub MFL 00	GP 00 K-30
BP	Energrease PR-EP 00	GLP 00 G-30
Esso	Beacon EP 0	KP 0 K-30
Esso	Grease TCL 435	GP 00/000 G-40
Fuchs-DEA	Renolit G-FHT 00	KP 00 P-30
Klüber	Microlube GB 0	KP 0 N-20
Mobil	Mobilux EP 004	GP 00 G-20
Optimol	Longtime PD 0	KP 0 N-30
Tribol	Tribol 3020/1000-00	GP 00 K-40

#### Oil lubricants

Manufacturer	Name	Specification
Agip	Exidia 220	Minimum requirements: CLP to DIN 51517 Viscosity ISO VG 220 to DIN 51519
Aral	Degol BG 220 plus	
Esso	Milcot K 220	
Fuchs-DEA	Renotac 345	
Klüber	Klüberoil GEM 1-220	
Optimol	Optigear BM 220	
Tribol	Molub-Alloy 90/220	

Normal temperature +10°C to +35°C

Environmental and operating conditions: High mechanical-dynamic loads

Examples

Machine tools  
Robots

Suitable lubricants

Grease lubricants

Manufacturer	Name	Specification
Agip	Autol Top 2000	KP 2 G-30
Aral	Aralub 4034	KP 2 K-20
BP	Energrease LC 2	KP 2 P-25
Esso	Ronex MP-D	
Fuchs-DEA	Renolit CXI 2	KP 2 P-20
Klüber	Microlube GL 261	KP 1 N-30
Mobil	Mobilith SHC 1500	KP 1 K-10
Optimol	Longtime PD 2	KP 2 K-40
Tribol	Tribol 3020/1000-2	KP 2 K-30

Liquid greases

Manufacturer	Name	Specification
Aral	Aralub MFL 00	GP 00 K-30
BP	Energrease PR-EP 00	GLP 00 G-30
Esso	Grease TCL 435	GP 00/000 G-40
Fuchs-DEA	Renolit G-FHT 00	KP 00 P-30
Klüber	Microlube GB 0	KP 0 N-20
Mobil	Mobilux EP 004	GP 00 G-20
Optimol	Longtime PD 0	KP 0 N-30

Oil lubricants

Manufacturer	Name	Specification
Agip	Blasia 680	Minimum requirements: CLP to DIN 51517 Viscosity ISO VG 680 to DIN 51519
Aral	Degol BG 680 plus	
BP	Energol GR-XP 680	
DEA	Falcon CLP 680	
Esso	Spartan EP 680	
Fuchs-DEA	Renolin CLP 680	
Klüber	Klüberoil GEM 1-220	
Mobil	Mobilgear XMP 680	
Optimol	Optigear BM 220	
Shell	Omala Oel 680	
Tribol	Tribol 1100/680	

# Lubrication Guide

## Suitable Lubricants

Normal temperature +10°C to +35°C

Environmental and operating conditions: Clean room / vacuum

### Examples

Computer industry  
Printed circuit-board production

### Suitable lubricants

#### Grease lubricants

Manufacturer	Name	Specification
BP	Energrease LS EP 2	KP 2 K-20
Fuchs-DEA	Renolit G 2000	
Klüber	Isoflex Topas NCA 52 <sup>1)</sup>	KHC 2 N-50
Klüber	Klüberalfa HX 83-302 <sup>2)</sup>	KPFK Z 4-60
Mobil	Mobilux EP 2	KP 2 K-10
Optimol	Inertox Medium	KFK 2 U-20
Tribol	Molub-Alloy 2115-1	KFFK 1 U-30

#### Liquid greases

Manufacturer	Name	Specification
BP	Energrease PR-EP 00	GLP 00 G-30
Mobil	Mobilux EP 004	GLP 00 G-20
Optimol	Inertox Fluid	KFK 0 U-20
Tribol	Molub-Alloy 2115-0	KFFK 0 U-30

#### Oil lubricants

Manufacturer	Name	Specification
BP	Energol GR-XP 68	
Esso	Vakuumpumpenöl 100 plus	
Mobil	Mobilgear 626	
Tribol	Tribol 1895	

<sup>1)</sup> Clean room

<sup>2)</sup> Ultra high vacuum

### N.B.:

The lubricants for clean room and vacuum applications sometimes contain solid lubricants and in some cases are **not** compatible with our anti-corrosion oil. Please check with us.

Normal temperature +10°C to +35°C

Environmental and operating conditions: USDA H1 requirements for the food industry

Examples

Filling and packing systems in the food industry  
Pharmaceutical industry

Suitable lubricants

Grease lubricants

Manufacturer	Name	Specification
Aral	Aralub 4822	KP 2 K-20
Aral	Eural Grease EP 2	KPHC 2 R-60
Esso	Carum 330	KP 1 K-20
Fuchs-DEA	Renolit G-7-FG 1	K 2 N-20
Klüber	Klübersynth UH 1 14-151	KHC 1 K-40
Mobil	Mobilgrease FM 102	K 2 K-20
Optimol	Obeen UF 2	KPHC 2 N-30
Tribol	FoodProof 8765	KP 1 K-30

Liquid greases

Manufacturer	Name	Specification
Aral	Eural Grease EP 000	KP 000
Klüber	Klübersynth UH 1 14-1600	GHC 00 K-40
Mobil	Mobilgrease FM 003	K 00 K-20
Optimol	Obeen UF 00	KPHC 00 N-40
Shell	Cassida RLS 00	KP 00 H-30

Oil lubricants

Manufacturer	Name	Specification
Aral	Eural Gear 220	Minimum requirements: CL to DIN 51517  Viscosity ISO VG 220 to DIN 51519
Esso	Gear Oil FM 220	
Klüber	Klüberoil GEM 1-220	
Optimol	Optileb GT 220	
Tribol	FoodProof 1810/220	

# Lubrication Guide

## Suitable Lubricants

Normal temperature +10°C to +35°C

Environmental and operating conditions: USDA H2 requirements for the food industry

Examples

Cosmetics industry  
Drinks industry

Suitable lubricants

Grease lubricants

Manufacturer	Name	Specification
Aral	Aralub 4822	KP 2 K-20
Klüber	Barrierta L 55/2	K 2 K-30
Klüber	Klüberplex BE 31-222	KP 2 K-20
Mobil	Mobilith SHC 220	KPHC 2 N-30
Optimol	Olit CLS	KP 2 K-30
Tribol	Tribob 4020/220-1	KP 1 N-30

Liquid greases

Manufacturer	Name	Specification
Aral	Euralgrease EP 000	KP 000
Klüber	Centoplex GLP 500	KP 000 K-30
Mobil	Mobil SHC 007	GPHC 00 N-40
Optimol	Olit CLS 0	KP 0 G-40
Tribol	Tribol 3020/1000-00	GP 00 K-40

Oil lubricants

Manufacturer	Name	Specification
Aral	Eural Gear 220	Minimum requirements: CLP to DIN 51517  Viscosity ISO VG 220 to DIN 51519
Klüber	Klüberoil GEM 1-220	
Optimol	Optileb GT 220	
Tribol	Tribol 1100/220	

**Normal temperature +10°C to +35°C**  
**Environmental and operating conditions: Aqueous media**

Examples

Machine tools  
 Cleaning systems

Suitable lubricants

Grease lubricants

Manufacturer	Name	Specification
Agip	Longtime Grease 2	KPE 2 N-40
Aral	Aralub MKL 2	KP 2 N-30
BP	Energrease LC 2	KP 2 P-25
Esso	Nebula EP 2	KP 2 K-20
Fuchs-DEA	Renolit CXI 2	KP 2 P- 20
Klüber	Klüberplex BE 31-222	KP 2 N-10
Mobil	Mobilgrease XHP 222	KP 2 N-20
Optimol	Olit CLS	KP 2 K-30
Tribol	Tribol 4020/460-2	KP 2 N-20

Liquid greases

Manufacturer	Name	Specification
BP	Energrease PR-EP 00	GLP 00 G-30
Fuchs-DEA	Renolit Epilith 00	GP 00 K-20
Mobil	Mobilith SHC 007	GPHC 00 N-40
Optimol	Olit CLS 0	KP 0 G-40
Tribol	Tribol 3020/1000-00	GP 00 K-40

Oil lubricants

Manufacturer	Name	Specification
Agip	Exidia 220	Minimum requirements:  CLP to DIN 51517  Viscosity ISO VG 220 to DIN 51519
Aral	Deganit BWX 220	
BP	Energol GR-XP 220	
Fuchs-DEA	Renep 220 K	
Mobil	Mobilgear XMP 220	
Optimol	Optileb GT 220	
Shell	Tonna Öl S 220	
Tribol	Molub-Alloy 90/220	

# Lubrication Guide

## Suitable Lubricants

Normal temperature +10°C to +35°C

Environmental and operating conditions: Diluted acids, alkalis, saline solutions (max. 10% solutions)

### Examples

Bottle cleaning machines  
Periphery of galvanizing and pickling lines

### Suitable lubricants

#### Grease lubricants

Manufacturer	Name	Specification
Agip	Autol Top 2000	KP 2 G-30
Aral	Aralub MKL 2	KP 2 N-30
BP	Energrease LC 2	KP 2 P-25
Fuchs-DEA	Renolit CXI 2	KP 2 P-20
Klüber	Klüberplex BE 31-222	KP 2 K-20
Mobil	Mobilgrease XHP 222	
Optimol	Olit CLS	KP 2 K-30

#### Liquid greases

Manufacturer	Name	Specification
BP	Energrease PR-EP 00	GLP 00 G-30
Fuchs-DEA	Renolit Epilith 00	GP 00 K-20
Mobil	Mobilith SHC 007	GPHC 00 N-40
Optimol	Olit CLS 0	KP 0 G-40

## High temperature up to +100°C

Environmental and operating conditions: Dry, relative humidity 35 - 70%

### Examples

Paper processing industry  
Tempering lines

### Suitable lubricants

#### Grease lubricants

Manufacturer	Name	Specification
Agip	Autol Top 2000 High Temp	KP 2 R-20
Aral	Aralub MKC 2	KP 2 N-30
BP	Energrease LC 2	KP 2 P-25
DEA	Glissando EP 2	KP 2 K-30
Esso	Norva HT 2	KP 2 N-10
Fuchs-DEA	Renolit Duraplex EP 2	KP 2 N-30
Klüber	Polylub GLY 791	KP 2 N-40
Mobil	Mobilux EP 2	KP 2 K-20
Optimol	Firetemp XT 2	KPHC 2 R-30
Shell	Albida EP 2	KP 2 N-30
Tribol	Tribol 9540-2	KPHC 2 R-40

#### Liquid greases

Manufacturer	Name	Specification
Aral	Aralub MFL 00	GP 00 K-30
BP	Energrease PR-EP 00	GLP 00 G-30
Fuchs-DEA	Renolit G-FHT 00	KP 00 P-30
Klüber	Klübersynth UH 1 14-1600	GHC 00 K-40
Mobil	Mobilux EP 004	GP 00 G-20
Optimol	Longtime PD 0	KP 0 N-40

#### Oil lubricants

Manufacturer	Name	Specification
Agip	Blasia 680	Minimum requirements: CLP to DIN 51517  Viscosity ISO VG 680 to DIN 51519
Aral	Degol BG 680	
Fuchs-DEA	Renolin Unisyn CLP 680	
Klüber	Klübersynth EG 4-680	
Mobil	SHC 639	
Optimol	Optileb GT 680	
Tribol	Tribol 800/680	

# Lubrication Guide

## Suitable Lubricants

High temperature up to +100°C

Environmental and operating conditions: Damp, relative humidity 70 - 100%

Examples

Steam degreasing systems  
Cleaning systems

Suitable lubricants

Grease lubricants

Manufacturer	Name	Specification
Agip	Autol Top 2000 High Temp	KP 2 R-20
Aral	Aralub MKC 2	KP 2 N-30
BP	Energrease LC 2	KP 2 P-25
DEA	Glissando EP 2	KP 2 K-30
Esso	Norva HT 2	KP 2 N-10
Fuchs-DEA	Renolit HLT 2	KP 2 N-40
Klüber	Polylub GLY 791	KP 2 N-40
Mobil	Mobilux XHP 222	KP 2 N-20
Optimol	Olista Longtime 2	KP 2 N-30
Shell	Albida RL2	KP 2 N-20
Tribol	Tribol 9141	KP 2/1 N-20

Liquid greases

Manufacturer	Name	Specification
Aral	Aralub MFL 00	GP 00 K-30
BP	Energrease PR-EP 00	GLP 00 G-30
Fuchs-DEA	Renolit G-FHT 00	KP 00 P-30
Klüber	Klübersynth UH 1 14-1600	
Mobil	Mobilith SHC 007	GPHC 00 N-40
Optimol	Viscofluid PD 300	KPE 000 N-20

Oil lubricants

Manufacturer	Name	Specification
Agip	Exidia 680	Minimum requirements: CLP to DIN 51517 Viscosity ISO VG 680 to DIN 51519
Aral	Degol BG 680	

## Low temperature down up -40°C

Environmental and operating conditions: Dry, relative humidity 35 - 70%

### Examples

Aerospace  
Refrigerating machines

### Suitable lubricants

#### Grease lubricants

Manufacturer	Name	Specification
Agip	Longtime Grease 2	KPE N-40
Aral	Aralub SEL	K 2 G-50
Esso	Unirex S 2	KE 2 S-50
Fuchs-DEA	Renolit S2	KP 1 K-60
Klüber	Isoflex LDS 18 Special A	KPe 2 K-50
Optimol	Optitemp TT1	KPE 1 K-60
Tribol	Mollub-Alloy 243 Arktik	KF 2/1 E-50

#### Liquid greases

Manufacturer	Name	Specification
Aral	Fließfett N	GP 00/000 G-40
Fuchs-DEA	Renolit GLS 00	GP 00 K-50
Klüber	Klübersynth UH 1 14-1600	GHC 00 K-40
Mobil	Mobilith SHC 007	GPHC 00 N-40
Optimol	Optitemp LG 0	KPHC 0 G-50
Tribol	Tribol 3020/1000-000	GP 000 K-40

#### Oil lubricants

Manufacturer	Name	Specification
Aral	Vitam HF 32	Minimum requirements: CLP to DIN 51517  Viscosity ISO VG 32 to DIN 51519
Esso	Univis N 32	
Optimol	Optileb HY 32	
Tribol	Tribol 1555/32	

# Lubrication Guide

## Applicable DIN Standards

Codes for Lubricants  
According to DIN 51502

	Code letters				
	K	P	2	K	-30
Type of grease lubricant					
Lubricating materials					
Consistency index (NLGI Class)					
Additional code letter (reaction to water)					
Additional code number for lower service temperature					

Example **K**P 2 K-30

Code letter	Type of grease lubricant
<b>K</b>	Grease lubricants for antifriction bearings, plain bearings and sliding faces according to DIN 51825
G	Grease lubricants for enclosed drives according to DIN 51826
OG	Grease lubricants for open drives, gearing (adhesive lubricants without bitumen)
M	Lubricants for plain bearings and seals

Lubricating materials

Example K**P**2 K-30

Code letter	Lubricating materials
D	for oil lubricants with detergent additives, e.g. hydraulic oil HLPD
E	for lubricants which are used mixed with water, e.g. water-miscible coolants, coolant SE
F	for lubricants with a solid lubricating additive (such as graphite, molybdenum sulfide), e.g. oil lubricant CLPF
L	for oil lubricants with active ingredients for increasing the resistance to corrosion and/or aging, e.g. oil lubricant C100 according to DIN 51517
M	for water-miscible coolants with mineral oil components, e.g. coolant SEM
S	for water-miscible coolants on a synthetic base, e.g. coolant SES
<b>P</b>	for lubricants with active ingredients for reducing friction and wear in the mixed friction zone and/or for increasing load capacity, e.g. oil lubricant CLP 100 according to DIN 51517
V	for lubricants diluted with solvents, e.g. oil lubricant BB-V according to DIN 51513

**Additional code letter\* for synthetic or partially synthetic liquids according to DIN 51502**

Example KP **(HC)**2 K-30

\* Not included in the code for lubricants according to DIN 51502

Code letter	Synthetic or partially synthetic liquids
E	Ester, organic
FK	Perfluor liquids
<b>(HC)</b>	Synthetic hydrocarbons
PH	Ester of phosphoric acid
PG	Polyglycols
SI	Silicon oils
X	Others

**Consistency index (NLGI- Class according to DIN 51818)**

Example KP **(2)**K-30

NLGI-Class	Worked penetration according to DIN ISO 2137
000	44,5 mm to 47,5 mm
00	40,0 mm to 43,0 mm
0	35,5 mm to 38,5 mm
1	31,0 mm to 34,0 mm
<b>(2)</b>	26,5 mm to 29,5 mm
3	22,0 mm to 25,0 mm
4	17,5 mm to 20,5 mm
5	13,0 mm to 16,0 mm
6	8,5 mm to 11,5 mm

**Additional code letter**

(reaction to water according to DIN 51807 Part 1, assessment level DIN 51807)

Example KP 2 **(K)**-30

- <sup>1)</sup> 0 stands for no change
- 1 stands for a slight change
- 2 stands for a moderate change
- 3 stands for a major change
- 40 test temperature +40 °C
- 90 test temperature +90 °C

Additional code letter	Upper operating temp.	Reaction to water <sup>1)</sup>
C	+ 60°C	0-40 or 1-40
D	+ 60°C	2-40 or 3-40
E	+ 80°C	0-40 or 1-40
F	+ 80°C	2-40 or 3-40
G	+ 100°C	0-90 or 1-90
H	+ 100°C	2-90 or 3-90
<b>(K)</b>	+ 120°C	0-90 or 1-90
M	+ 120°C	2-90 or 3-90
N	+ 140 °C	by agreement
P	+ 160 °C	by agreement
R	+ 180 °C	by agreement
S	+ 200 °C	by agreement
T	+ 220 °C	by agreement
U	over + 220 °C	by agreement

**Additional code number for lower Seville temperature**

Example KP 2 K **(-30)**

Additional code number	Lower service temperature
-10	-10 °C
-20	-20 °C
<b>(-30)</b>	-30 °C
-40	-40 °C
-50	-50 °C
-60	-60 °C

# Lubrication Guide

## Applicable DIN Standards

### K, KP, KF and KPF grease lubricants according to DIN 51825

#### K grease lubricants

K grease lubricants are high-viscosity lubricants made of mineral oil and/or synthetic oil plus a thickening agent. The addition of active ingredients and/or solid lubricants is permitted. Codes are the same as those in DIN 51502.

#### KP grease lubricants

K grease lubricants with active ingredients for reducing friction and wear in the mixed friction zone and/or for increasing load capacity are identified with the additional code letter P (**KP** grease lubricants). They are used, for example, to lubricate antifriction bearings whose dynamic equivalent load P exceeds one tenth of the dynamic load capacity C (see the information published by the manufacturer of the antifriction bearings).

#### KF grease lubricants

K grease lubricants with solid lubricating additives are identified with the additional code letter F.

#### KPF grease lubricants

K grease lubricants containing active ingredients and solid lubricating additives are identified by the two additional code letters P and F.

### C, CL, CLP and CGLP oil lubricants according to DIN 51517

#### C oil lubricants

C oil lubricants according to DIN 51517 are aging-resistant mineral oils without active ingredients. Their codes are the same as those in DIN 51502.

#### CL oil lubricants

CL oil lubricants are recommended when there is a risk of corrosion, e.g. due to water, or when the service life of type C oil lubricants used at high temperatures would be too short.

CL oil lubricants according to DIN 51 517 are mineral oils with active ingredients for increasing the resistance to corrosion and aging (L).

#### CLP oil lubricants

CLP oil lubricants are recommended when enhanced wear protection in the mixed friction zone is required for friction areas due to high loads and/or it is necessary to prevent surface damage such as score marks caused by overloading.

CLP oil lubricants according to DIN 51 517 are mineral oils with active ingredients for increasing the resistance to corrosion and aging (L) plus active ingredients for reducing wear in the mixed friction zone (P).

#### CGLP oil lubricants

CGLP oil lubricants are recommended when there is a need for constant sliding characteristics and high adhesion (e.g. for horizontal and vertical guide tracks). Good demulsifying characteristics prevent mixing with water-miscible coolants.

CGLP oil lubricants according to DIN 51 517 are mineral oils with active ingredients for increasing the resistance to corrosion and aging (L) plus active ingredients for reducing wear in the mixed friction zone (P) plus very good sliding characteristics (G).

## HL, HLP and HVLP hydraulic oils according to DIN 51524

### HL hydraulic oils

HL hydraulic oils according to DIN 51524 are hydraulic fluids made of mineral oils with active ingredients for increasing the resistance to corrosion and aging.

Type of hydr. oil	Requirements					
Identification according to DIN 51502	HL 10	HL 22	HL 32	HL 46	HL 68	HL 100
ISO viscosity class according to DIN 51519	ISO VG 10	ISO VG 22	ISO VG 32	ISO VG 46	ISO VG 68	ISO VG 100

### HLP hydraulic oils

HLP hydraulic oils according to DIN 51524 are hydraulic fluids made of mineral oils with active ingredients for increasing the resistance to corrosion and aging and for preventing fretting in the mixed friction zone.

Type of hydr. oil	Requirements					
Identification according to DIN 51502	HLP 10	HLP 22	HLP 32	HLP 46	HLP 68	HLP 100
ISO viscosity class according to DIN 51519	ISO VG 10	ISO VG 22	ISO VG 32	ISO VG 46	ISO VG 68	ISO VG 100

### HVLP hydraulic oils

HVLP hydraulic oils according to DIN 51524 are hydraulic fluids made of mineral oils with active ingredients for increasing the resistance to corrosion and aging, for preventing fretting in the mixed friction zone, and for improving the viscosity-temperature characteristic.

Type of hydr. oil	Requirements				
Identification according to DIN 51502	HVLP 15	HVLP 32	HVLP 46	HVLP 68	HVLP 100
ISO viscosity class according to DIN 51519	ISO VG 15	ISO VG 32	ISO VG 46	ISO VG 68	ISO VG 100

# Lubrication Guide

## Applicable DIN Standards

ISO viscosity classification  
for oil lubricants according  
to DIN 51519

Viscosity class ISO	Center viscosity at +40 °C [mm <sup>2</sup> /s]	Kinematic Viscosity limits at +40 °C [mm <sup>2</sup> /s]	
		min.	max.
ISO VG 2	2,20	1,98	2,42
ISO VG 3	3,20	2,88	3,52
ISO VG 5	4,60	4,14	5,06
ISO VG 7	6,80	6,12	7,48
ISO VG 10	10,00	9,00	11,00
ISO VG 15	15,00	13,50	16,50
ISO VG 22	22,00	19,80	24,20
ISO VG 32	32,00	28,80	35,20
ISO VG 46	46,00	41,40	50,60
ISO VG 68	68,00	61,20	74,80
ISO VG 100	100,00	90,00	110,00
ISO VG 150	150,00	135,00	165,00
ISO VG 220	220,00	198,00	242,00
ISO VG 320	320,00	288,00	352,00
ISO VG 460	460,00	414,00	506,00
ISO VG 680	680,00	612,00	748,00
ISO VG 1000	1000,00	900,00	1100,00
ISO VG 1500	1500,00	1350,00	1650,00
ISO VG 2200	2200,00	1980,00	2420,00
ISO VG 3200	3200,00	2880,00	3520,00

# Notes

Bosch Rexroth Corporation  
Linear Motion and  
Assembly Technologies  
14001 South Lakes Drive  
Charlotte, NC 28273  
Phone: 800-438-5983  
Fax: 704-583-0523  
info.chr@boschrexroth-us.com  
www.boschrexroth-us.com

Bosch Rexroth Corporation  
5150 Prairie Stone Parkway  
Hoffman Estates, IL 60192-3707  
Phone: 847-645-3600  
Fax: 847-645-0811

Bosch Rexroth Corporation  
Industrial Hydraulics  
2315 City Line Road  
Bethlehem, PA 18017-2131  
Phone: 610-694-8300  
Fax: 610-694-8467

Bosch Rexroth Corporation  
Electric Drives and Controls  
5150 Prairie Stone Parkway  
Hoffman Estates, IL 60192-3707  
Phone: 847-645-3600  
Fax: 847-645-6201

Bosch Rexroth Corporation  
Pneumatics  
1953 Mercer Road  
Lexington, KY 40511-1021  
Phone: 859-254-8031  
Fax: 859-281-3483

Bosch Rexroth Corporation  
Mobile Hydraulics  
P.O. Box 394  
1700 Old Mansfield Road  
Wooster, OH 44692-0394  
Phone: 330-263-3300  
Fax: 330-263-3333