

## Electro-Motor-Pumps ET



motion and progress

## Contents

1	General information	3
2	D.C. Electric motors	3
3	Gear pumps	6
4	Starter relays	6
5	Electro-Motor-Pumps for group 05 pumps	8
6	D.C. Electric motors for group 05 pumps	9
7	Drive and connecting flange for group 05 pumps	15
8	Group 05 gear pumps	16
9	Electro-Motor-Pumps for group 1 pumps	18
10	D.C. Electric motors for group 1 pumps	19
11	Drives and connecting flange for group 1 pumps	27
12	Group 1 gear pumps	28
13	Components	30
14	Order designation examples of Electro-Motor-Pumps	30

## 1 General information

Electro-motor-pump is the simplest and more compact unit able to supply hydraulic power, as flow and pressure, to oil-dynamic actuators.

The Electro-motor-pumps are largely used on industrial operating machines particularly on mobile machines, where, through simple valves and hoses connections it makes possible to operate and control different hydraulics actuators.

In the present technical catalogue the most common versions, obtained as combination of DC motors and External Gear Pumps, either 05 (AP05) and 1 (AP100) group, are shown, although, many and different customised versions have been designed and realised in order to satisfy to specific and dedicated customer' requests.

## 2 D.C. Electric motors

### 2.1 Technical information

#### Versions:

Available voltage: 12-24 V D.C.

Available power rating: 0.8 - 3 kW.

For other input voltage and power rating, consult our Sales Department.

#### Direction of rotation:

Unless otherwise stated, all motors are specified clockwise rotation, suitable for driving counterclockwise pumps.

### Directives and standards

- **Atex:**

The equipment and protective systems of these catalogue ARE NOT intended for use in potentially explosive atmospheres that is to say where there is an explosive atmosphere referred to in Article 2 of the Directive 99/92/EC and referred to Article 1.3 of the Directive 94/9/EC.

- **ISO 9001: 2000**

Bucher Hydraulics S.p.A. is certified for research, development and production of directional control valves, power units, gear pumps and motors, electro pumps, cartridge valves and integrated operating blocks for hydraulic applications.

#### Permanent magnets

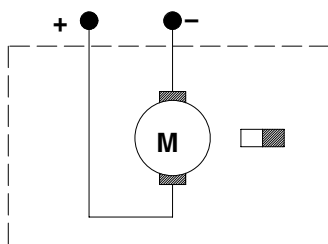

#### Series

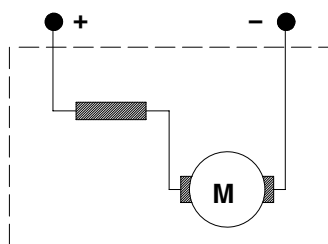

#### Compound

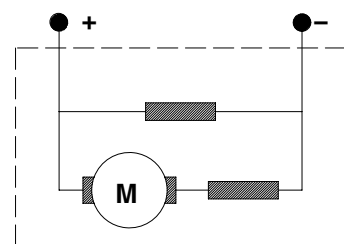

#### Insulation class:

The class of electric insulation reflects the maximum temperature motor can register during operation without damage to the insulating material internally of motor itself. The following table indicates insulation classes to CEI 15-26.

Class	Y	A	E	B	F	H
Temperature (°C)	90	105	120	130	155	180

#### Type of duty:

To ensure selection of the electric motor best suited to a given set of operating conditions, the duty cycle needs to be verified. Duty cycles S1, S2 and S3 are defined below in accordance with CEI 2-3

#### Type of winding:

D.C. motors can be manufactured with different types of field windings:

- Permanent magnets
- Series
- Compound

#### Continuous duty S1:

Operation on-load (Steady conditions) for a period of indefinite duration, during which the motor reaches thermal equilibrium without exceeding the maximum permissible temperature.

#### Short time duty S2

Operation on-load (steady conditions) for a period of limited duration, denoted  $t_d$ , during which maximum permissible temperature is reached, followed by an off-load period of duration sufficient for the temperature of the motor to return to ambient temperature.

#### Intermittent duty S3

A sequence of identical cycles, each 10 minutes in duration, the single cycle comprises a period of operation on-load ( $t_d$ ), during which the motor may reach its maximum permissible temperature followed by an off-load period of limited duration ( $t_m$ ), insufficient for the temperature of the motor to return to ambient temperature. The value of S3 indicates the duration of the on-load period ( $t_d$ ) in relation to the overall cycle time ( $t_p$ ), as a percentage.

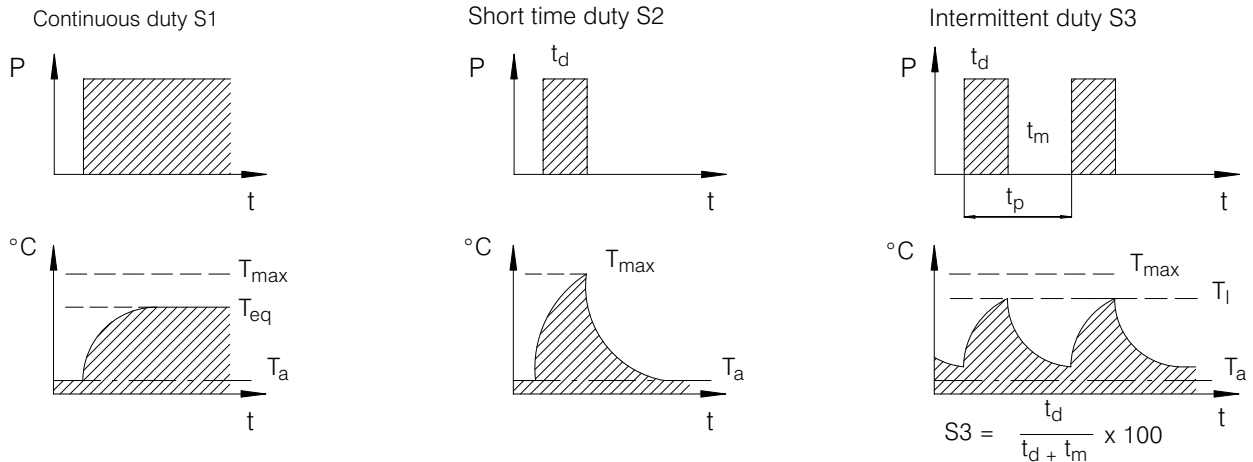

**P** = load  
**T<sub>eq</sub>** = temperature at thermal equilibrium  
**T<sub>max</sub>** = maximum permissible temperature  
**T<sub>I</sub>** = operating temperature  
**T<sub>a</sub>** = ambient temperature  
**t<sub>d</sub>** = duration of on-load period  
**t<sub>m</sub>** = duration of off-load period  
**t<sub>p</sub>** = duration of cycle (10 min.)

**Protection degree:**

This indicates the level of protection afforded in preventing contact between live parts of the motor and people or foreign matter generally, and preventing the penetration of

water.

The degree of protection is indicated in accordance with CEI 2-16 by the initials IP and two identifying digits:  
Example:

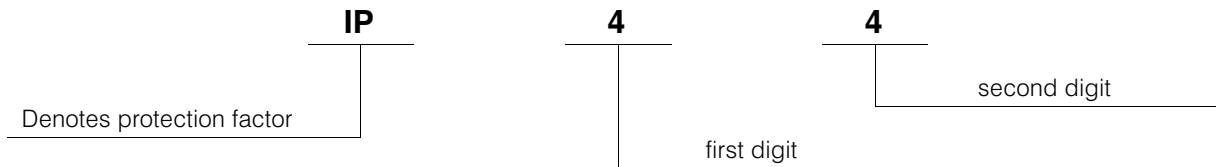

The first digit indicates the degree of protection afforded to the motor against contact with people or foreign bodies.

<b>0</b>	no protection
<b>1</b>	protection against solid particles measuring > 50 mm
<b>2</b>	protection against solid particles measuring > 12 mm
<b>3</b>	protection against solid particles measuring > 2.5 mm
<b>4</b>	protection against solid particles measuring > 1 mm
<b>5</b>	protection against dust

The second digit indicates the degree of protection afforded to the motor against the effects of penetration by water.

The degree of protection indicated for each individual electric motor refers to the motor when mounted to a Bucher Hydraulics S.p.A. electro-motor-pump.

<b>0</b>	no protection
<b>1</b>	protection against water dripping vertically
<b>2</b>	protection against water dripping at 15° max
<b>3</b>	protection against rain
<b>4</b>	protected against water splash
<b>5</b>	protected against water spray

## 2.2 Characteristic curves

Characteristic curves are given for each motors, from which to establish pressure, flow rate and current

consumption values, and S2 and S3 duty cycles.

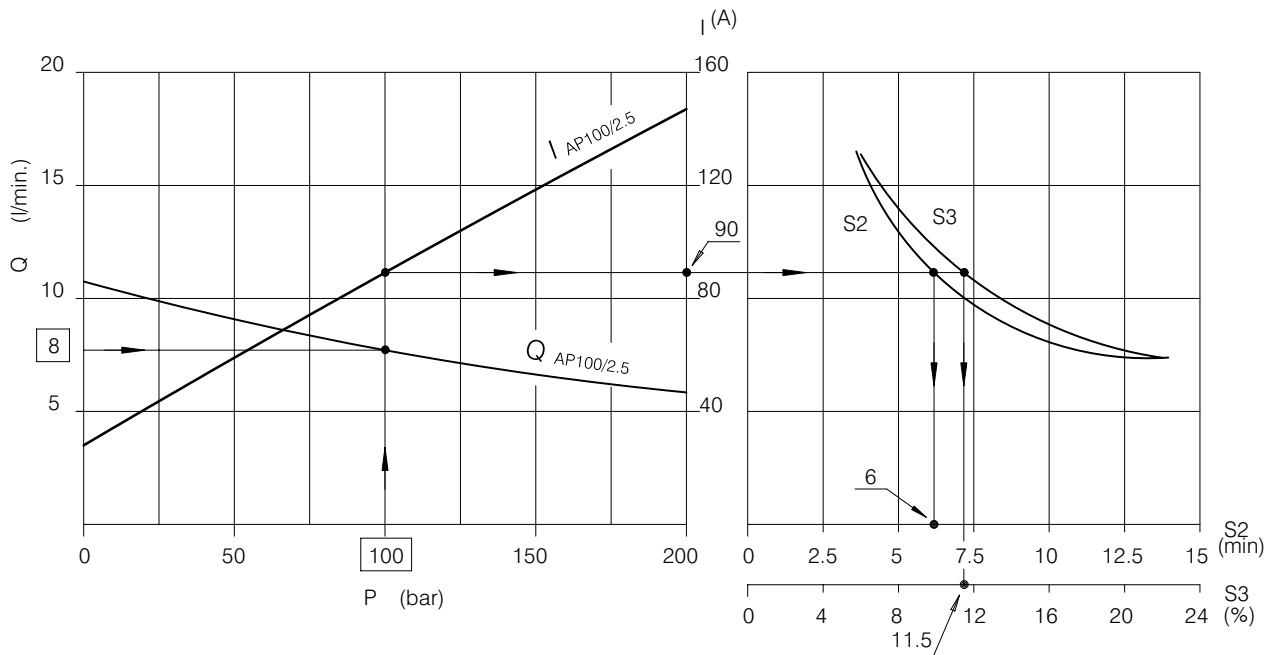

## 2.3 Example of how the graphs are used

### Required data

Flow rate  $Q = 8$  l/min  
Pressure  $p = 100$  bar

### Pump displacement

Determined by the intersection of the required  $p$  and  $Q$  curves.

In the example indicated, pump AP100/2.5 has the required  $p$  and  $Q$  specifications.

In the event that there is no point of intersection with any curve, a displacement as near as possible to the required flow rate should be selected.

### Current consumption

This is determined by taking a vertical line from the pressure value to its point of intersection with the  $I$  curve corresponding to the selected displacement.

In the example illustrated, current consumption is:  
 $I = 90$  Ampere

### Type of use

Having established the current, the relationship of the  $S2$  and  $S3$  curves will give the following values:  
 $S2 = 6$  min.  $S3 = 11.5\%$

## 2.4 Mounting directions

The tie bolts must not be withdrawn completely when fitting motors, but retracted a short distance (30–50 mm max).

Once fitted to the electro-motor-pump, the motor should be run off-load momentarily (5 seconds max) to verify its correct operation: supply power to the windings and measure the current drain, which must not exceed the following values:

24 V motor -  $I < 35$  Ampere  
12 V motor -  $I < 70$  Ampere

### Power cable

The wire selected for power connections must be of cross section appropriate for the rated current of the motor.

### Tightening torques

When assembling the motor and power pack and securing the wires of the power cable to the motor terminals, observe the tightening torque values indicated.

### Brush life

The brushes will wear down progressively with continued operation of the motor, and must be replaced when reduced to their minimum useful length.

Since the rate of wear on the brushes is dictated by the operating conditions and cannot therefore be broadly specified, consult our Sales Department for guidance.

### 3 Gear pumps

#### 3.1 Suitable fluids

Only mineral oil based hydraulic fluids responding to ISO/ DIN standard should be used.

Viscosity range:

recommended 20 - 120 mm<sup>2</sup>/s (cSt)

permissible up to 700 mm<sup>2</sup>/s (cSt)

Operating temperature range: -15 +80 °C

For other fluids consult our Sales Department.

**\* Caution! – Use of pumps at temperatures above 80°C must always be agreed upon with our Technical Office, and in any case this can cause a significant worsening in the volumetric efficiency.**

**For use under conditions different from those indicated in this catalogue, please contact our Sales Department.**

#### 3.2 Inlet

Absolute pressure at the pump inlet must be

$V > 0.75$  bar (11 PSI)

Accordingly, avoid:

- significant differences in height of pump and tank
- long pipeline runs
- sharp bends, restrictions, etc. causing turbulent flow

In certain applications, inlet pressure may be higher than 1 bar (14.3 PSI), or at any rate higher than atmospheric.

For pumps with standard configuration, the pressure registering at the gauge M1 should be:

$M1 < 3.5$  bar (50 PSI).

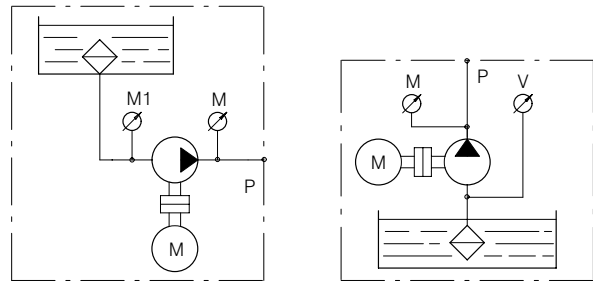

#### 3.3 Outlet

Pressure levels:

P1 = continuous operating pressure

P2 = intermittent operating pressure

P3 = peak pressure

The recommended delivery pipe oil speed is between:  $v = 2 - 5$  m/s

In the next pages are indicated the performances for each pump.

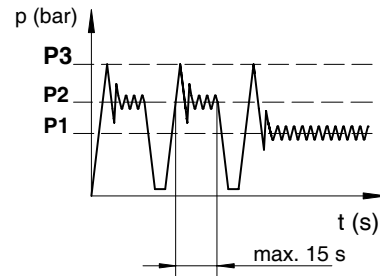

### 4 Starter relays

Technical information

Versions:

Available voltages: 12-24 V D.C.

Standard: suitable for most applications.

Heavy duty: for more arduous conditions

See relative table for technical data

Contact life:

The contacts of the relay will wear down progressively during operation.

Since the rate of wear is dedicated by the type of duty and cannot therefore be broadly specified, consult our Sales dept. for guideline information.

Fitment to electric motor

Starter relays can be fitted to the frame of the motor by two different methods:

#### 1. Direct

The relay is secured with screws, using holes already tapped in motor frame. In this instance there is one standard mounting position only.

#### 2. Metal clip

Suitable for standard relays only.

The relay is secured by means of a clip encircling the motor frame and inserted through special slots in the feet of the relay itself.

In this instance, several mounting positions are possible.

#### Electrical diagram

A typical arrangement for connection of the relay to the electric motor is shown in the diagram.

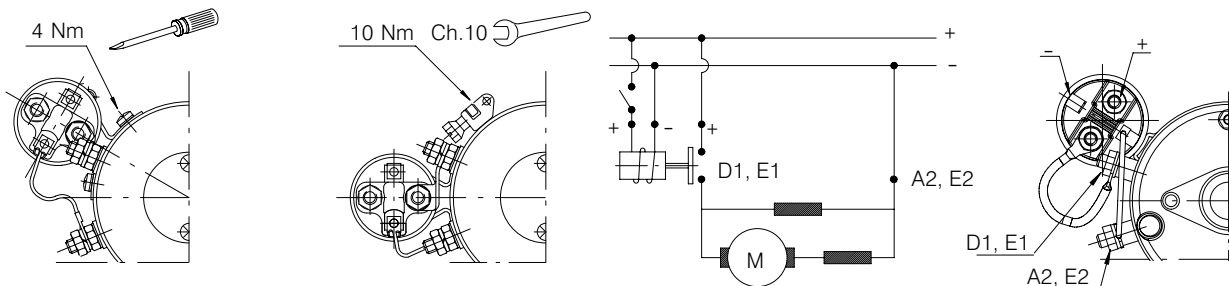

### Motor starter relays

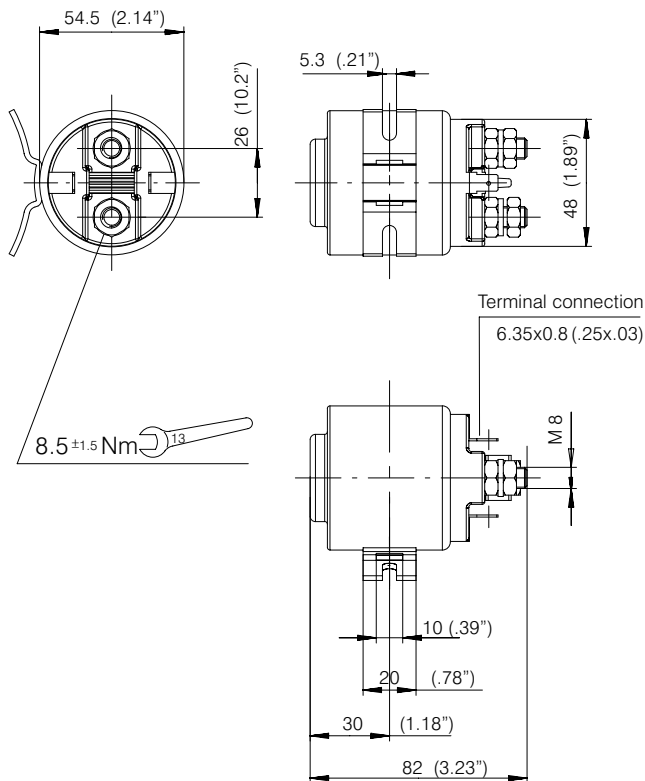

Weight : 0.70 Kg (1.52 lb)

Voltage	12 V	24 V
<b>Type</b>	<b>R106</b>	<b>R209</b>
<b>Code</b>	<b>200544134106</b>	<b>200544134209</b>
Amps Consumption by the coil	2.8 A	1.1 A
Current for continuous duty		80 A
Max. current (5 sec.)		500 A
Protection index		IP54
Insulation class		F
Electric diagram		

### Heavy duty version

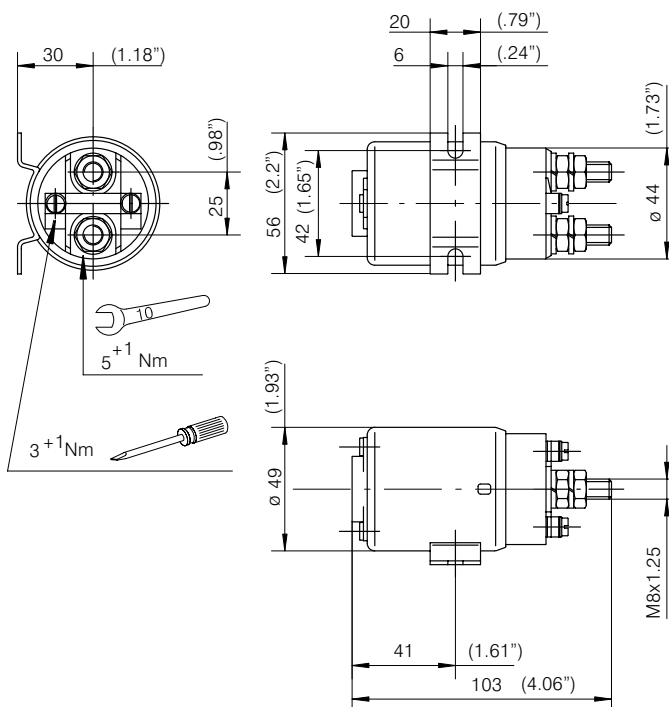

Weight : 0.78 Kg (1.69 lb)

Voltage	12 V	24 V
<b>Type</b>	<b>R107</b>	<b>R210</b>
<b>Code</b>	<b>200544134107</b>	<b>200544134210</b>
Amps Consumption by the coil	2 A	1.1 A
Current for continuous duty		150 A
Max. current (5 sec.)		800 A
Protection index		IP42
Insulation class		B
Electric diagram		

5 Electro-Motor-Pumps for group 05 pumps

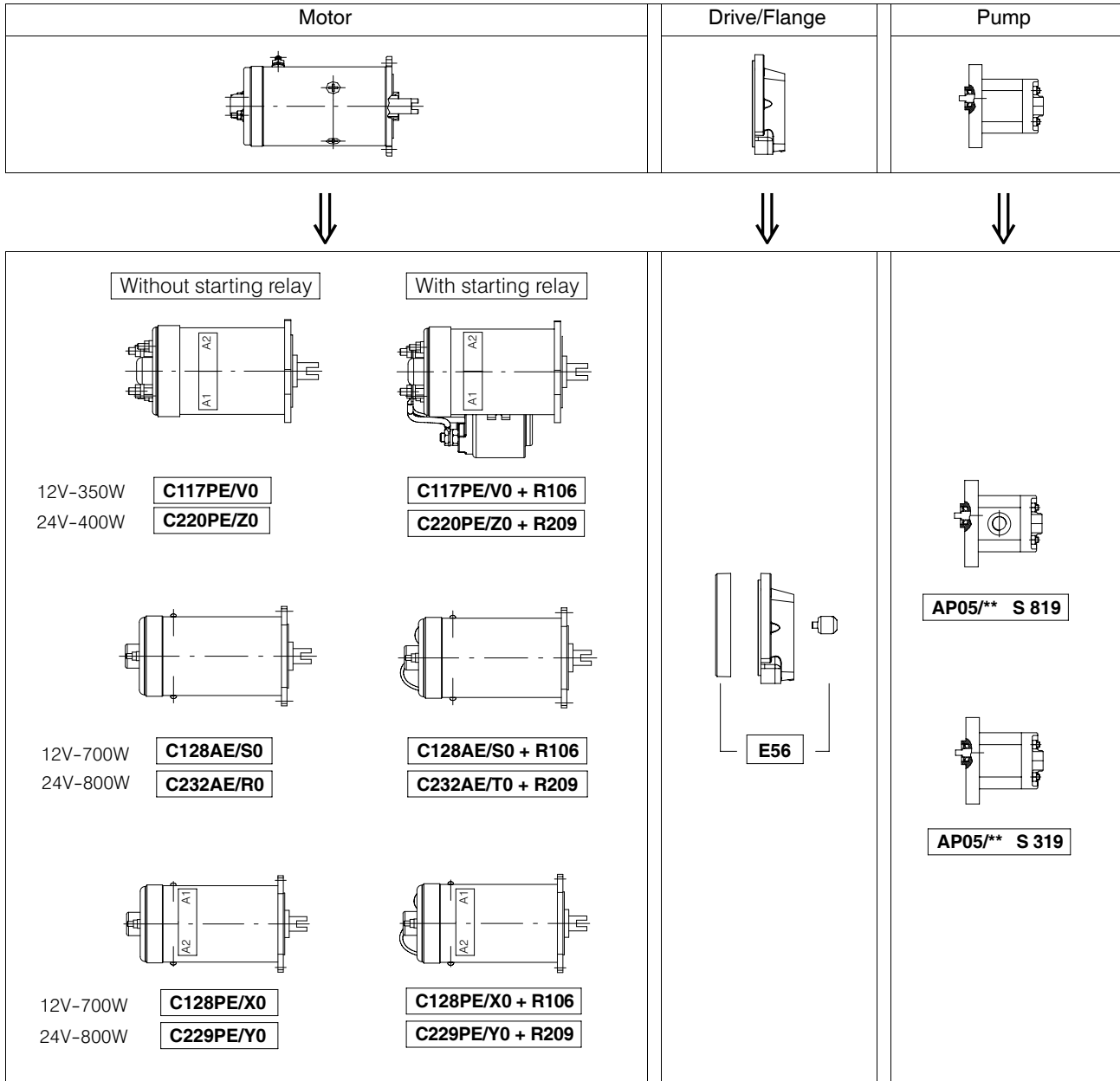

## 6 D.C. Electric motors for group 05 pumps

Voltage	12 V	24 V
Nominal Power	350 W	400W

Protection index: ..... IP54  
 Insulation class: ..... F  
 Type of winding: ..... Permanent magnets  
 Brushes kit: ..... 200544138021  
 Relay fixing kit ..... 200544108005  
 Minimum brushes length: ..... 6 mm (0.24 inches)

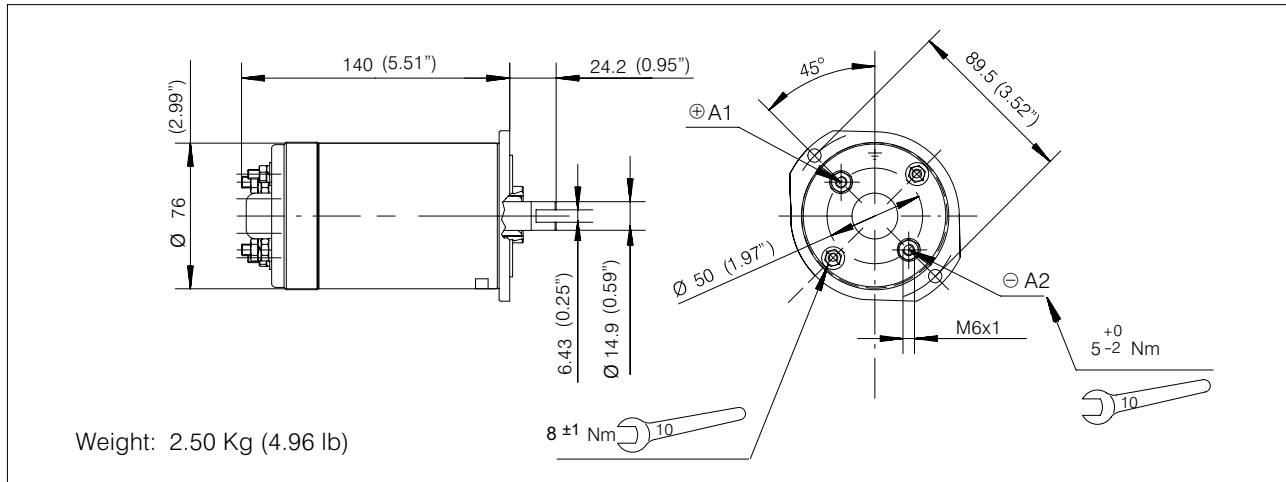

	Motor		Motor with relay			
Rotation Right						
Type	<b>C117PE/V0</b>	<b>C220PE/Z0</b>	<b>C117PE/V0 + R106</b>	<b>C220PE/Z0 + R209</b>		
Code	200543911701	200543922001	200763310130	200763320130		
Relay			The standard single relay can be used for clock-wise rotation only			
Relay type			<b>R106</b>	<b>R209</b>		

### Motor mounting position

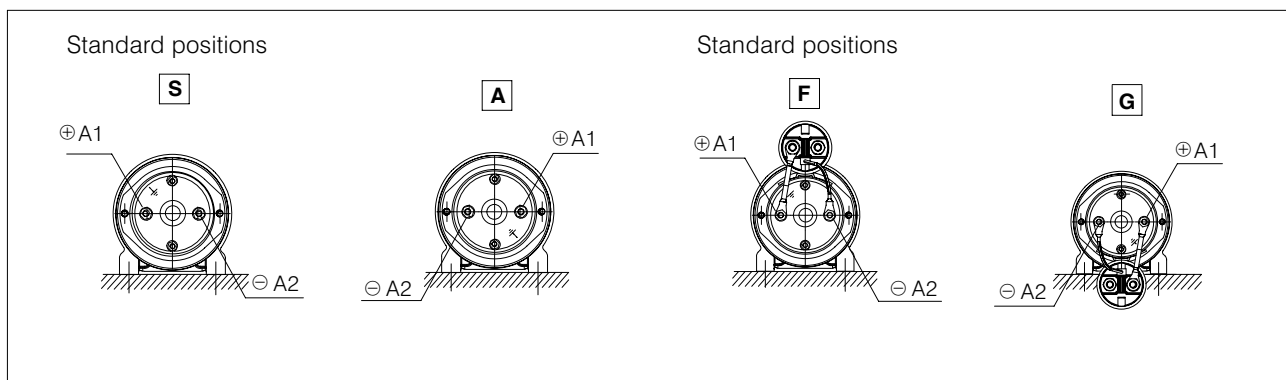

**12 V – 350 W**

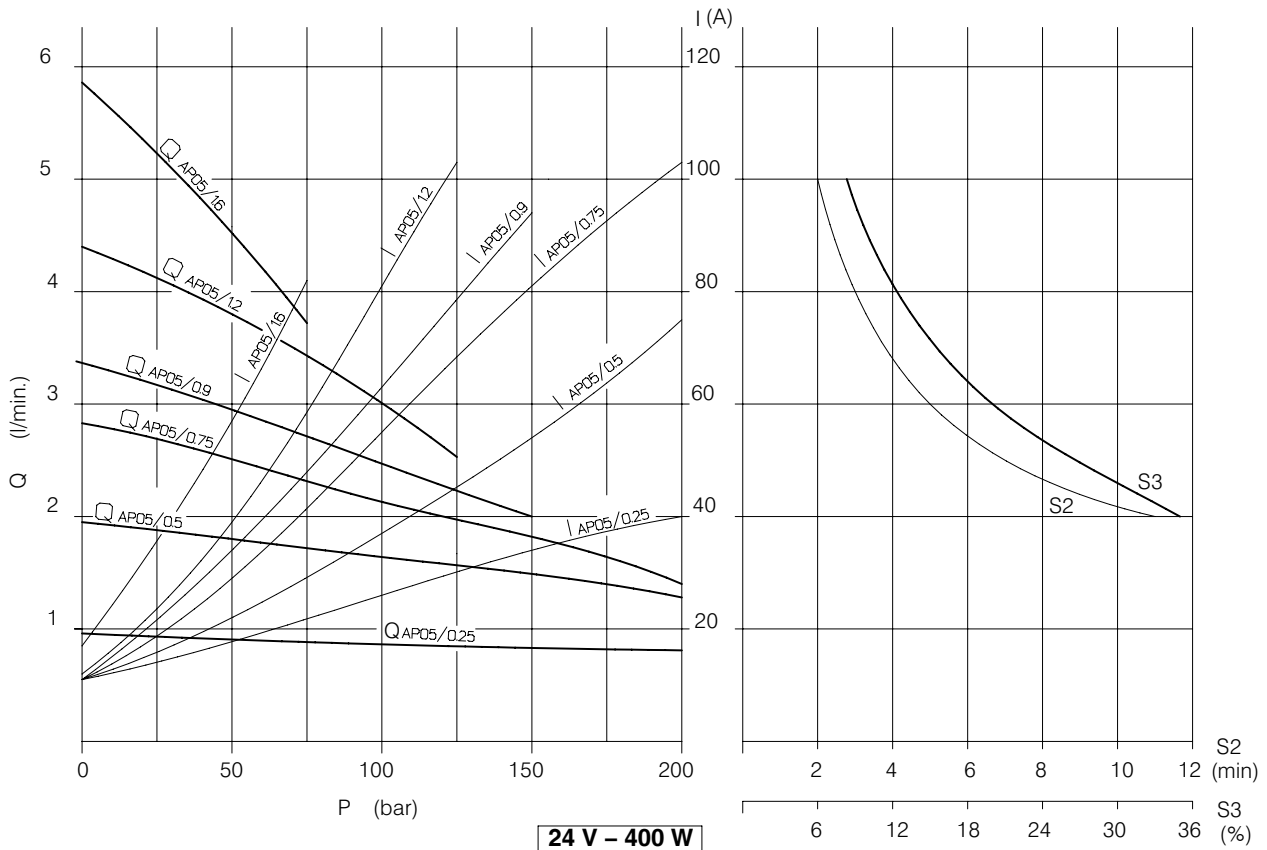

**24 V – 400 W**

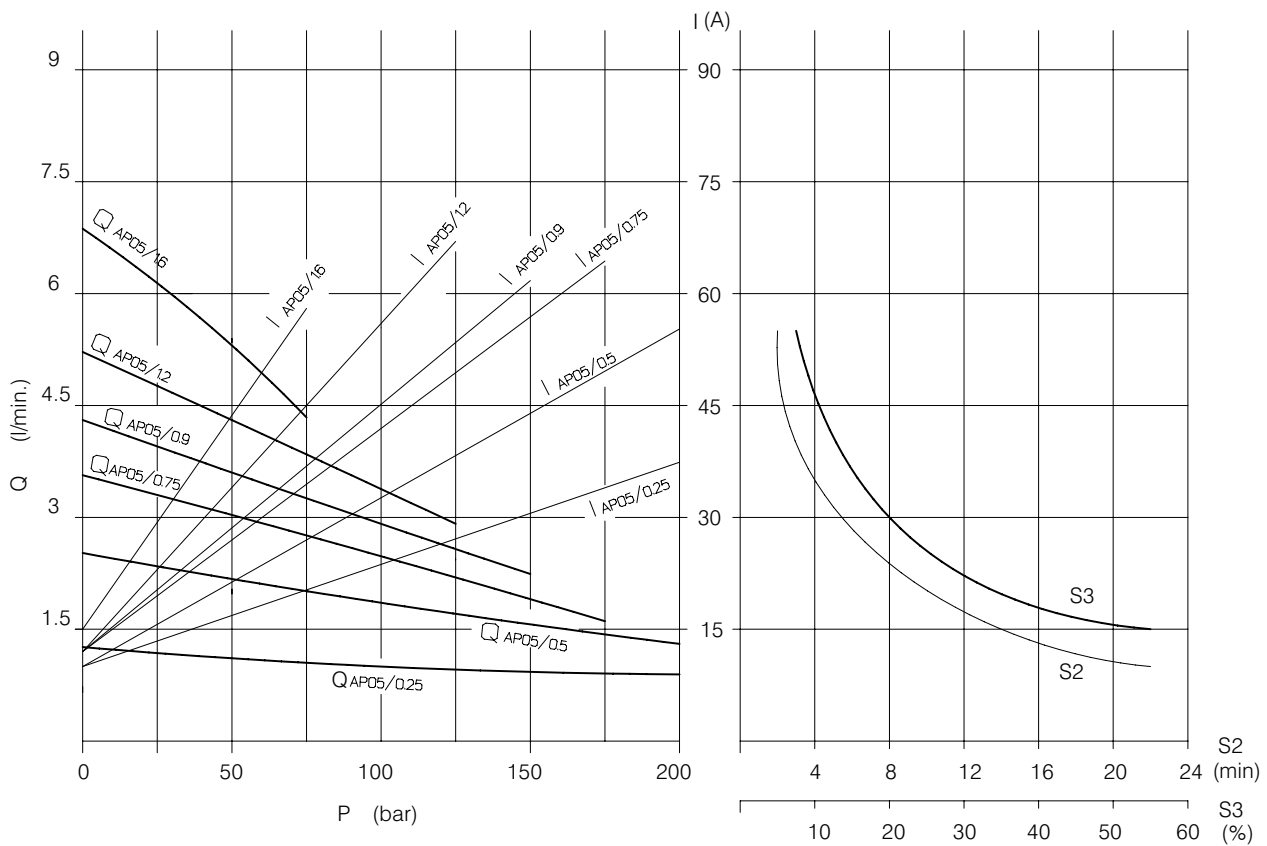

Voltage	12 V	24 V
Nominal Power	700 W	800 W

Protection index: ..... IP54  
 Insulation class: ..... F  
 Type of winding: ..... Compound  
 Brushes kit: ..... 200544138026  
 Relay fixing kit ..... 200544108005  
 Minimum brushes length: ..... 5 mm (0.2 inches)

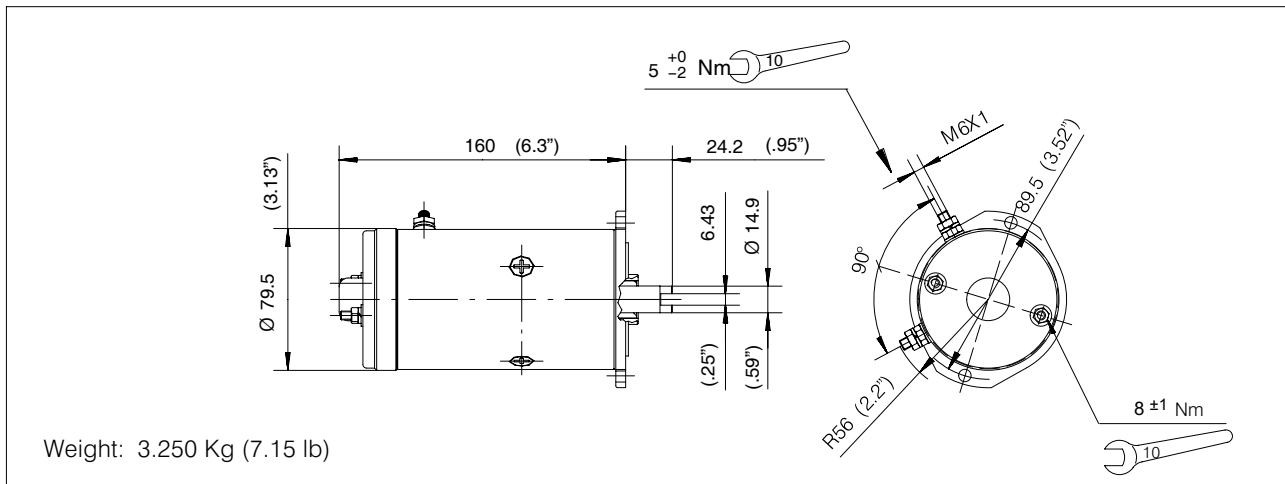

	Motor		Motor with relay			
Rotation Right						
	12 V - 700 W	24 V - 800 W	12 V - 700 W	24 V - 800 W		
Type	<b>C128AE/S0</b>	<b>C232AE/R0</b>	<b>C128AE/S0 + R106</b>	<b>C232AE/R0 + R209</b>		
Code	200543912804	200543923203	200763310140	200763320140		
Relay			STANDARD			
Relay type			R106	R209		

Motor mounting position

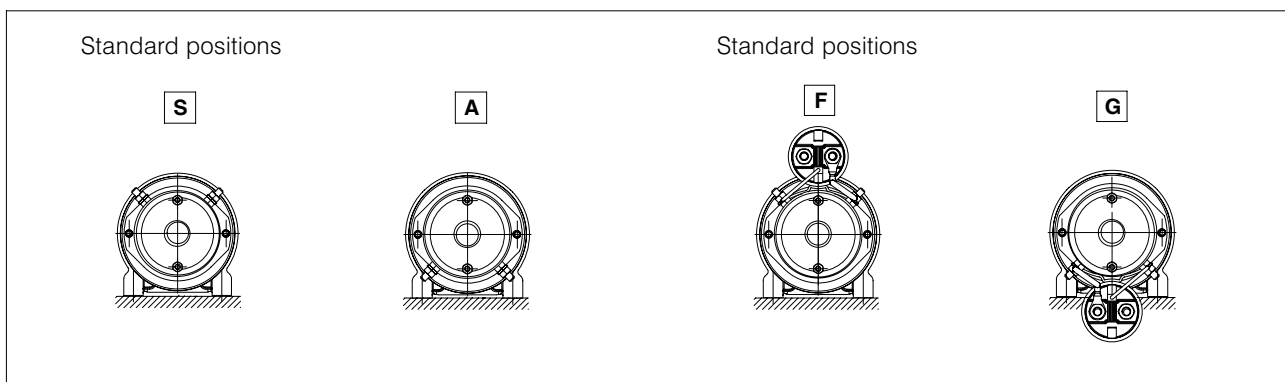

**12 V – 700 W**

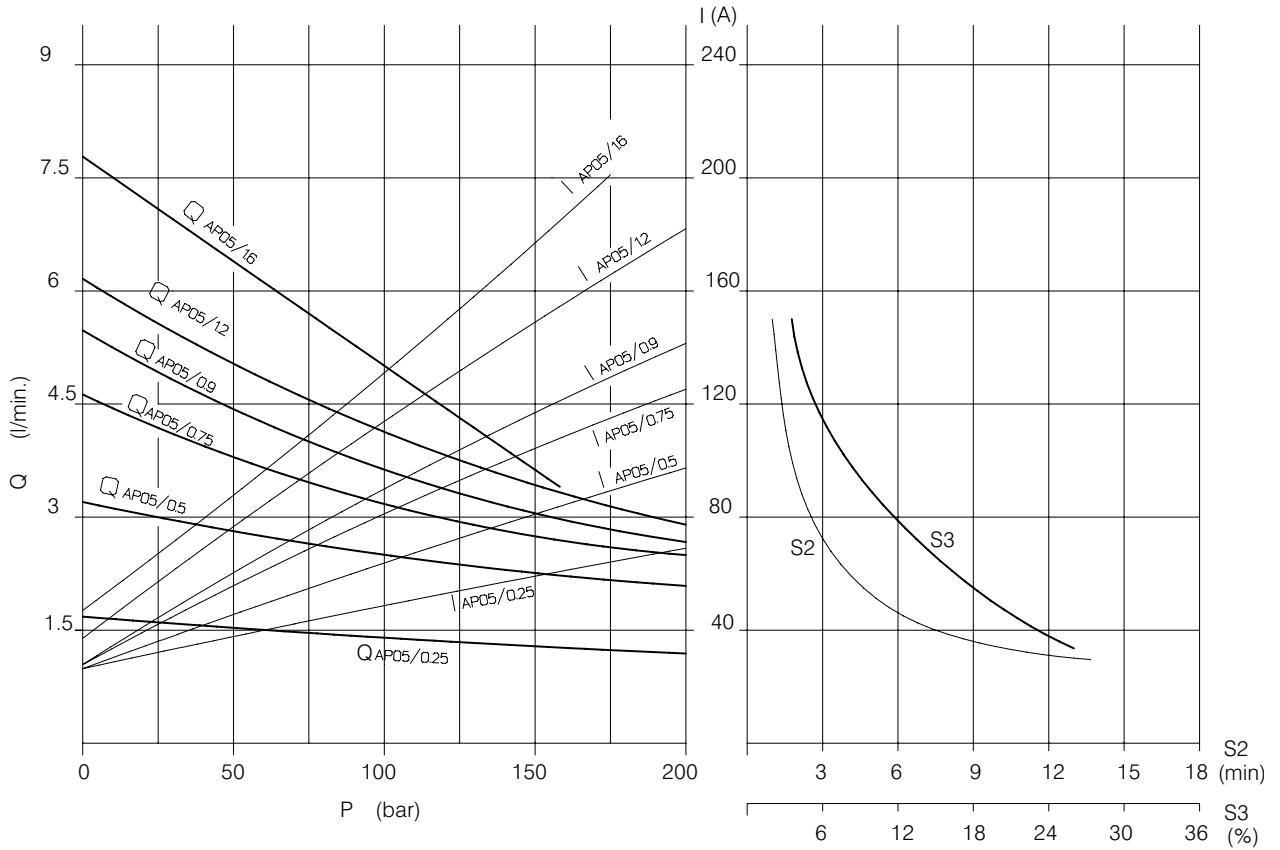

**24 V – 800 W**

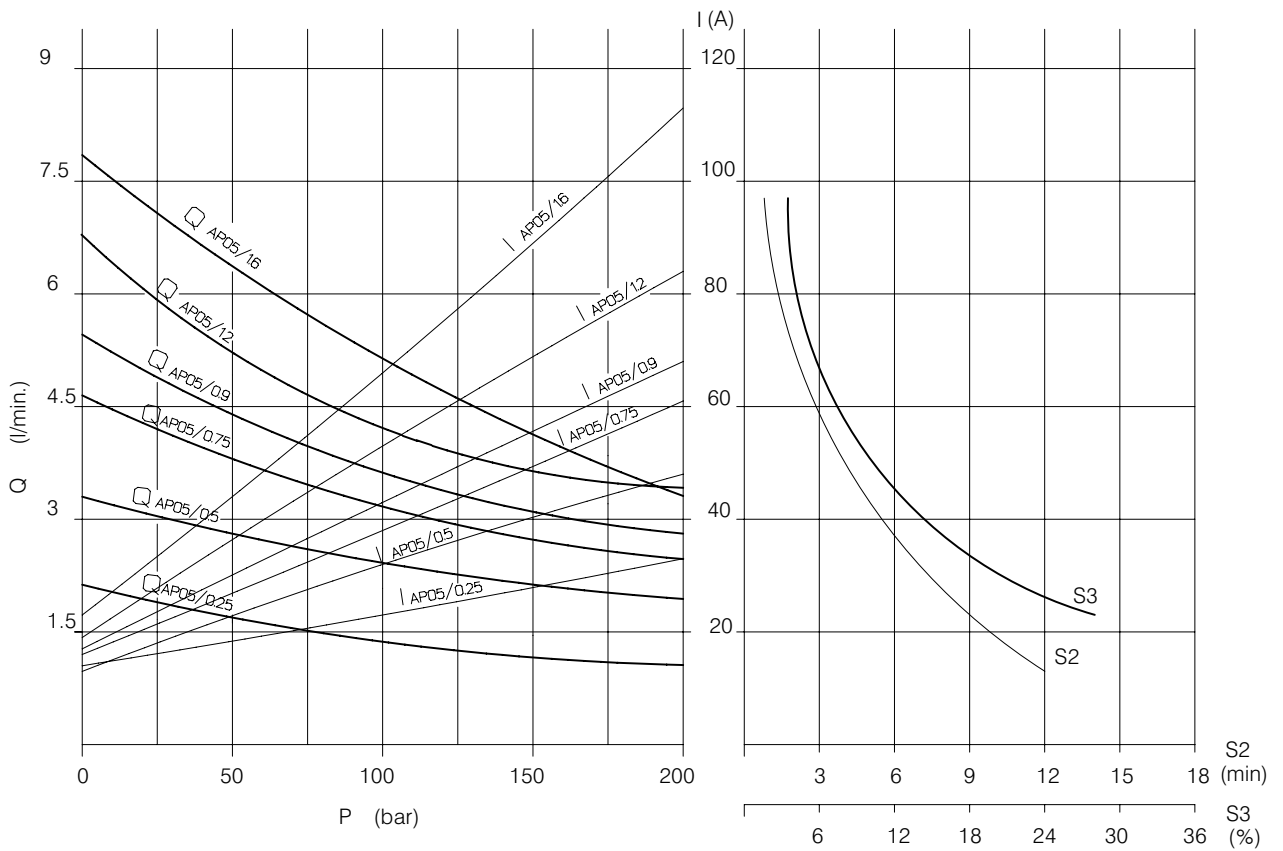

Voltage	12 V	24 V
Nominal Power	700 W	800W

Protection index: ..... IP54  
 Insulation class: ..... F  
 Type of winding: ..... Permanent magnets  
 Brushes kit: ..... 200544138026  
 Relay fixing kit ..... 200544108005  
 Minimum brushes length: ..... 5 mm (0.2 inches)

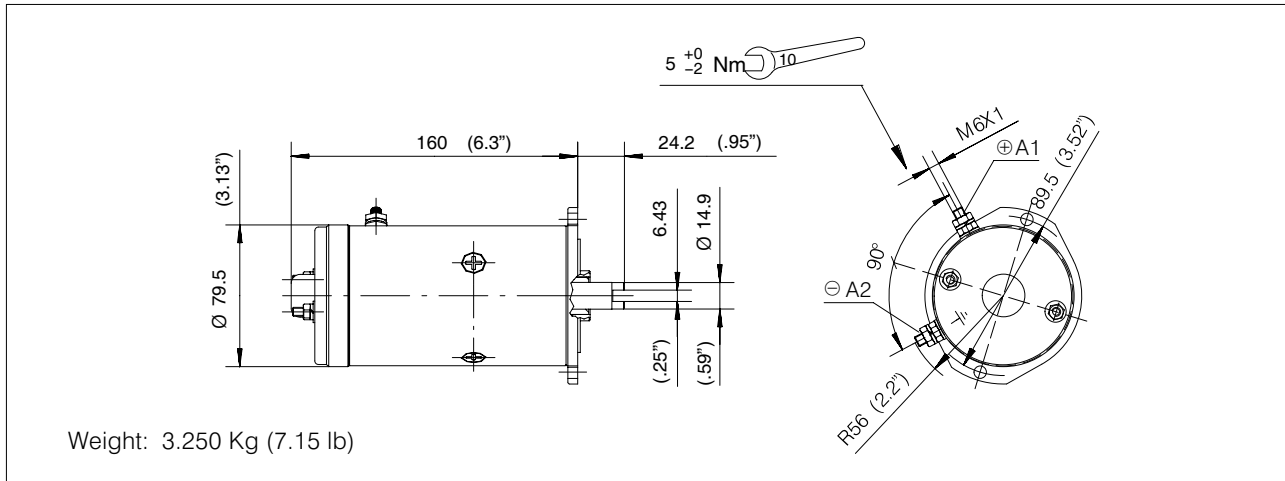

	Motor		Motor with relay		
Rotation	Right		Right		
Type	<b>C128PE/X0</b>	<b>C229PE/Y0</b>	<b>C128PE/X0 + R106</b>	<b>C229PE/Y0 + R209</b>	
Code	200543912806	200543922901	200763310120	200763320150	
Relay			The standard single relay can be used for clock-wise rotation only		
Relay type			R106	R209	

**Motor mounting position**

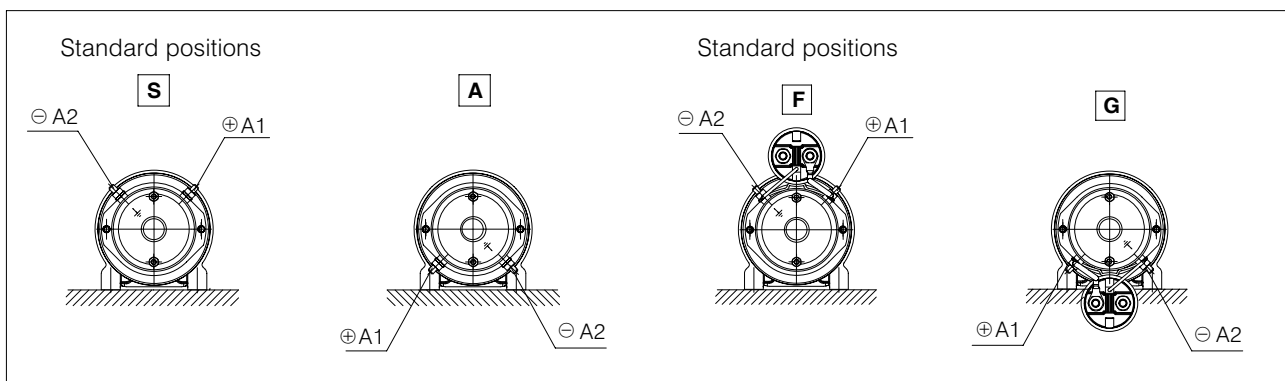

**12 V – 700 W**

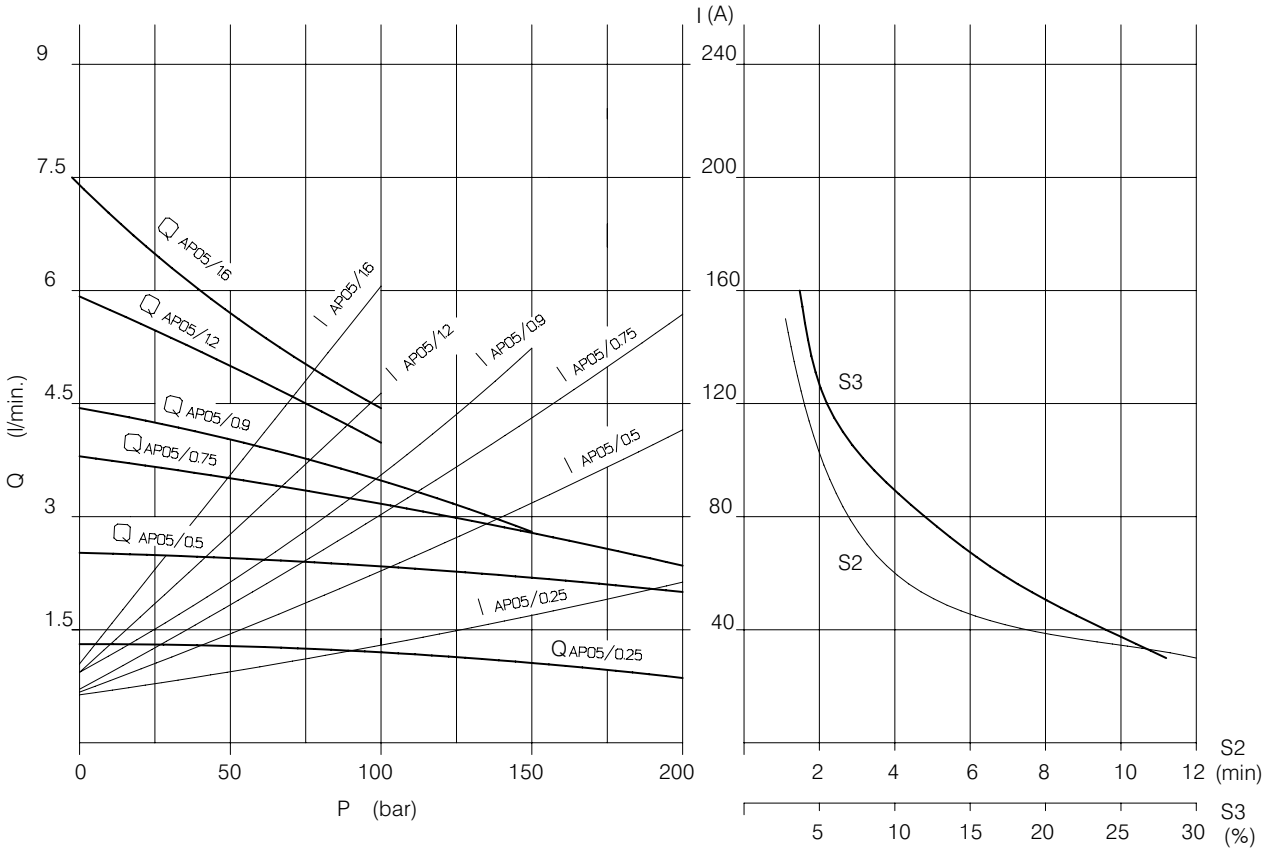

**24 V – 800 W**

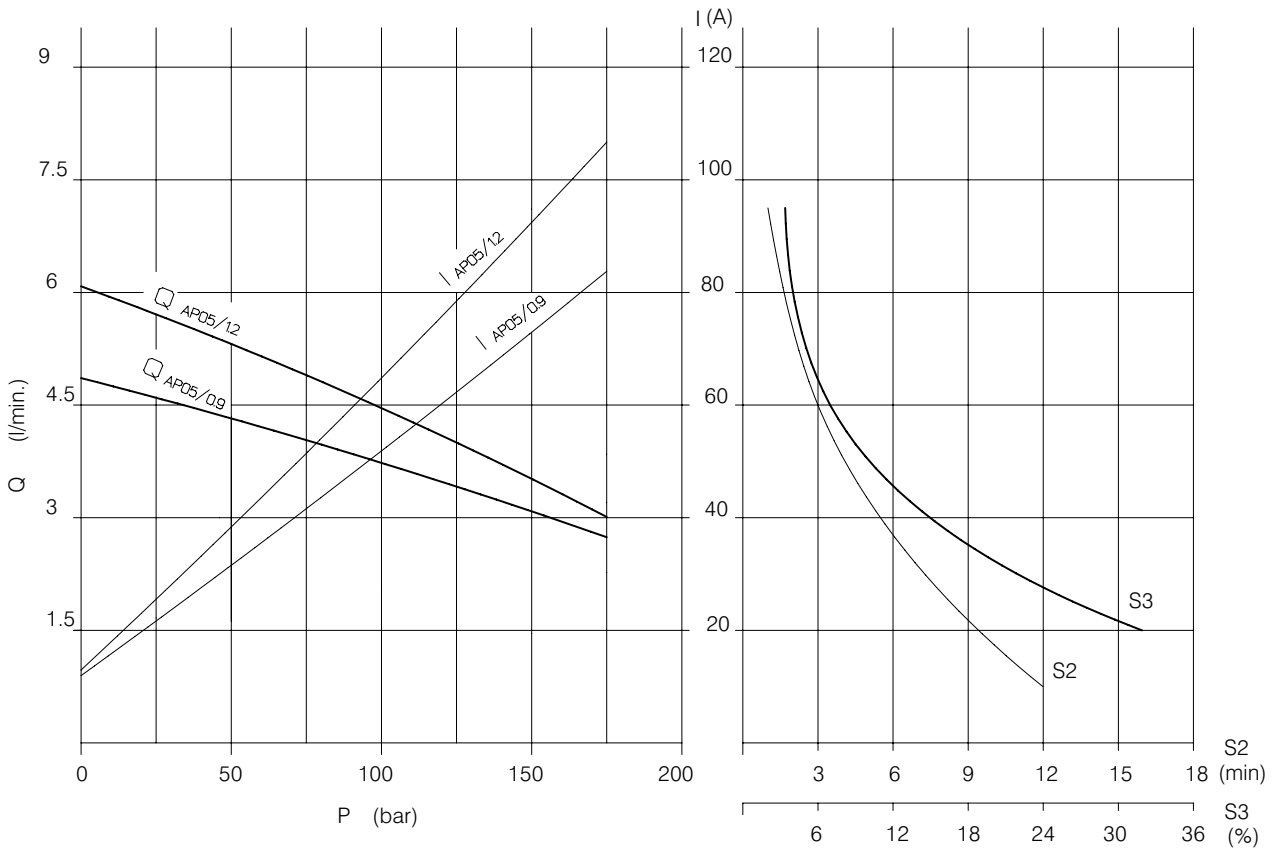

**7 Drive and connecting flange for group 05 pumps**

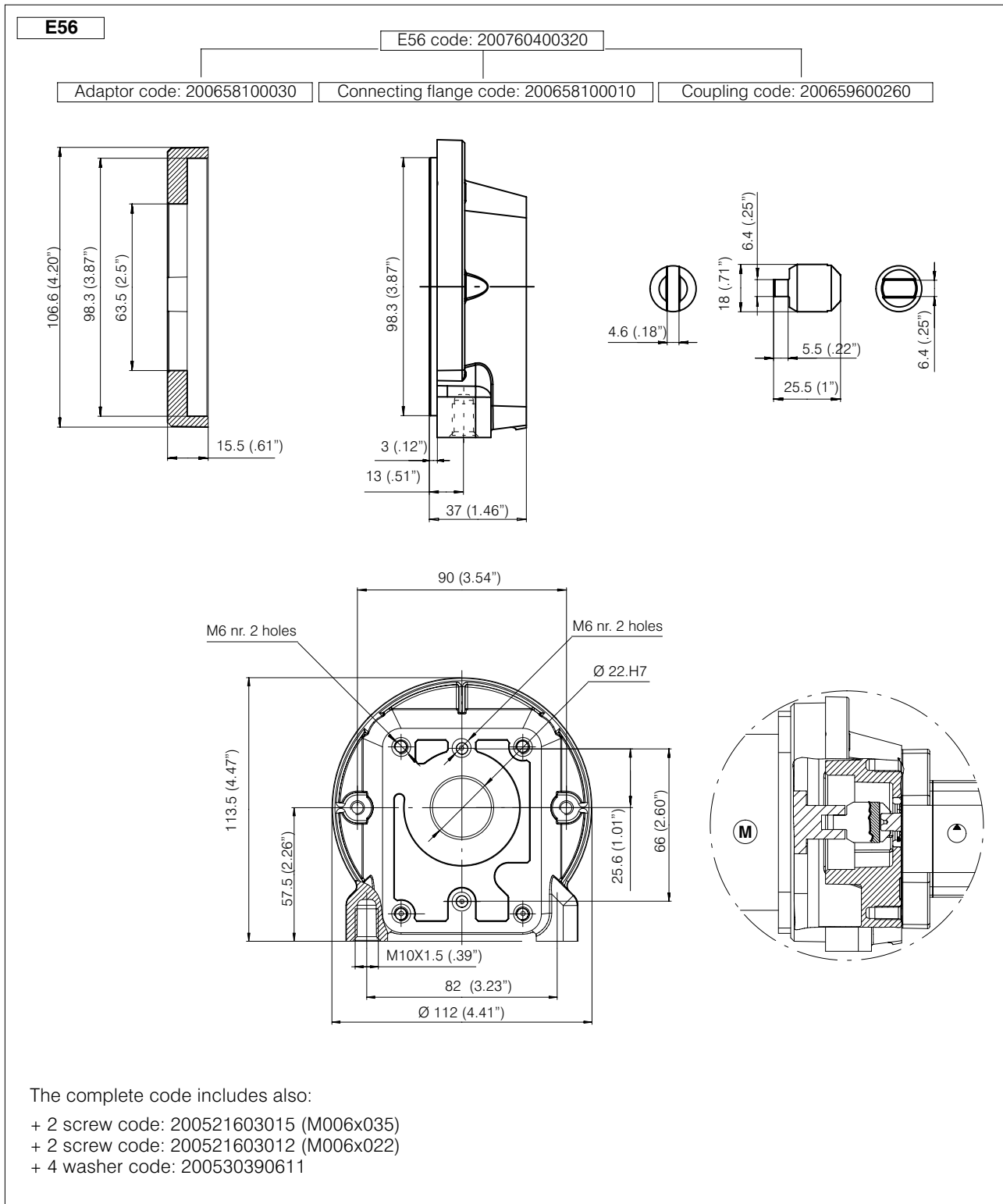

**8 Group 05 gear pumps**

AP05 Type	Displacement		Max. pressure						n min.		n max.	
	cm <sup>3</sup> /rev	Cu. In. P. R.	P1		P2		P3		P ≤ P1	P > P1	P ≤ P1	P > P1
			bar	P.S.I.	bar	P.S.I.	bar	P.S.I.				
<b>AP05/0.25</b>	0.25	.015	170	2400	180	2600	200	2900	800	1000	6000	7000
<b>AP05/0.5</b>	0.5	.030	190	2700	210	3000	230	3300	650	800	6000	7000
<b>AP05/0.75</b>	0.75	.045	190	2700	210	3000	230	3300	650	800	6000	7000
<b>AP05/0.9</b>	0.9	.055	190	2700	210	3000	230	3300	650	800	6000	7000
<b>AP05/1.2</b>	1.2	.073	170	2400	180	2600	200	2900	550	700	5000	6000
<b>AP05/1.6</b>	1.6	.097	170	2400	180	2600	200	2900	550	700	5000	6000

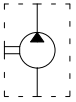

Group **AP05** Code **819**

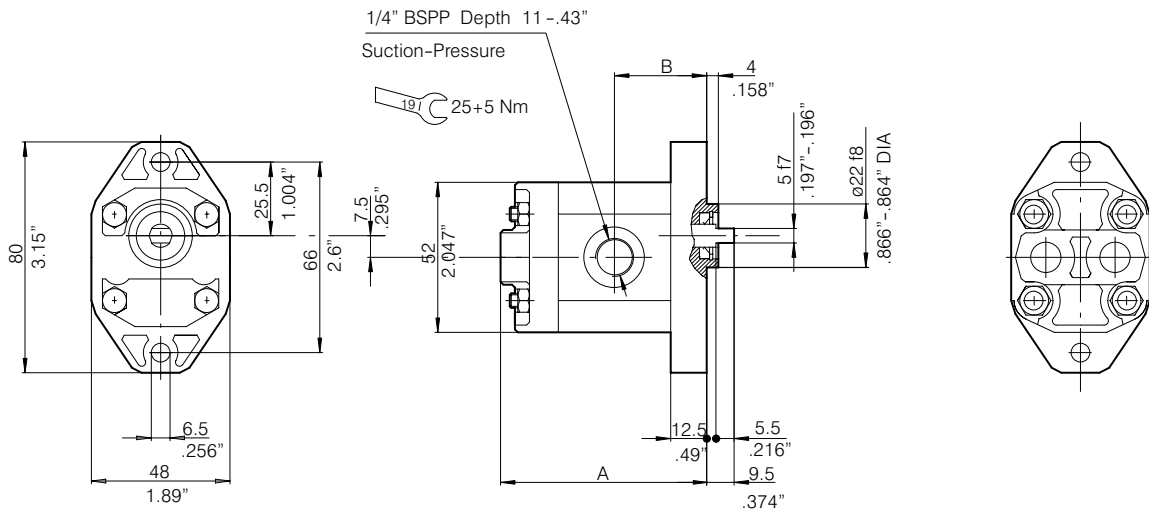

Type	Displacement cm <sup>3</sup> /rev	Dimensions				Order code Counterclockwise rotation: S	
		A		B			
		mm	inches	mm	inches		
<b>AP05/0.25</b>	0.25	64.5	2.54	29	1.41	<b>200100264304</b>	
<b>AP05/0.5</b>	0.5	67	2.64	30.5	1.2	<b>200100364302</b>	
<b>AP05/0.75</b>	0.75	69	2.72	31.5	1.24	<b>200100464302</b>	
<b>AP05/0.9</b>	0.9	70.5	2.77	32.3	1.26	<b>200100564304</b>	
<b>AP05/1.2</b>	1.2	73	2.87	33.5	1.32	<b>200100664302</b>	
<b>AP05/1.6</b>	1.6	77	3.03	35.5	1.40	<b>200100864301</b>	

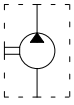

Group **AP05** Code **319**

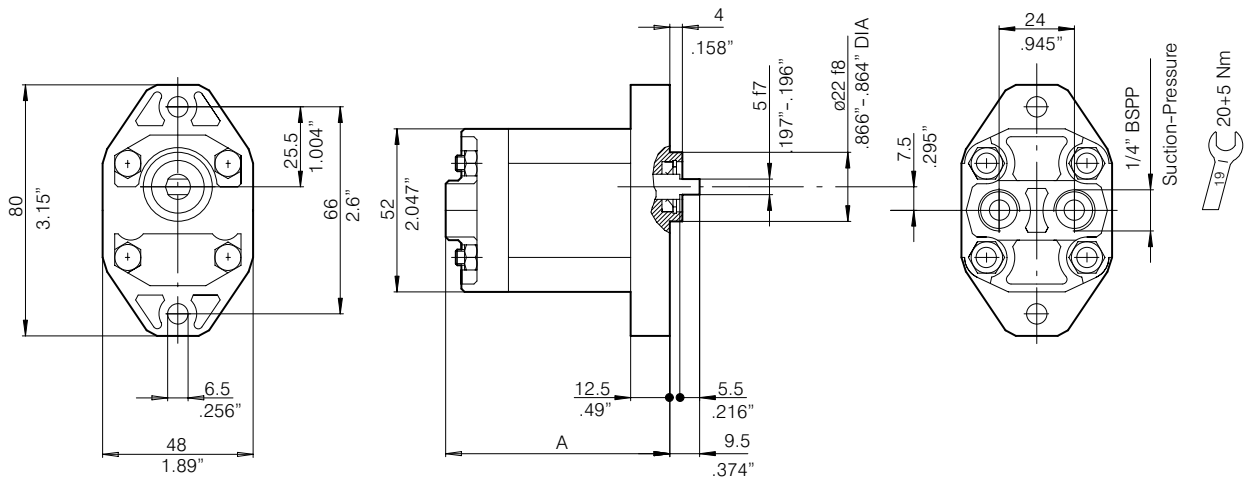

Type	Displacement cm <sup>3</sup> /rev	Dimensions		Order code Counterclockwise rotation: S	
		A			
		mm	inches		
<b>AP05/0.25</b>	0.25	64.5	2.54	<b>200100214301</b>	
<b>AP05/0.5</b>	0.5	67	2.64	<b>200100314301</b>	
<b>AP05/0.75</b>	0.75	69	2.72	<b>200100414301</b>	
<b>AP05/0.9</b>	0.9	70.5	2.77	<b>200100514301</b>	
<b>AP05/1.2</b>	1.2	73	2.87	<b>200100614301</b>	
<b>AP05/1.6</b>	1.6	77	3.03	<b>200100814301</b>	

9 Electro-Motor-Pumps for group 1 pumps

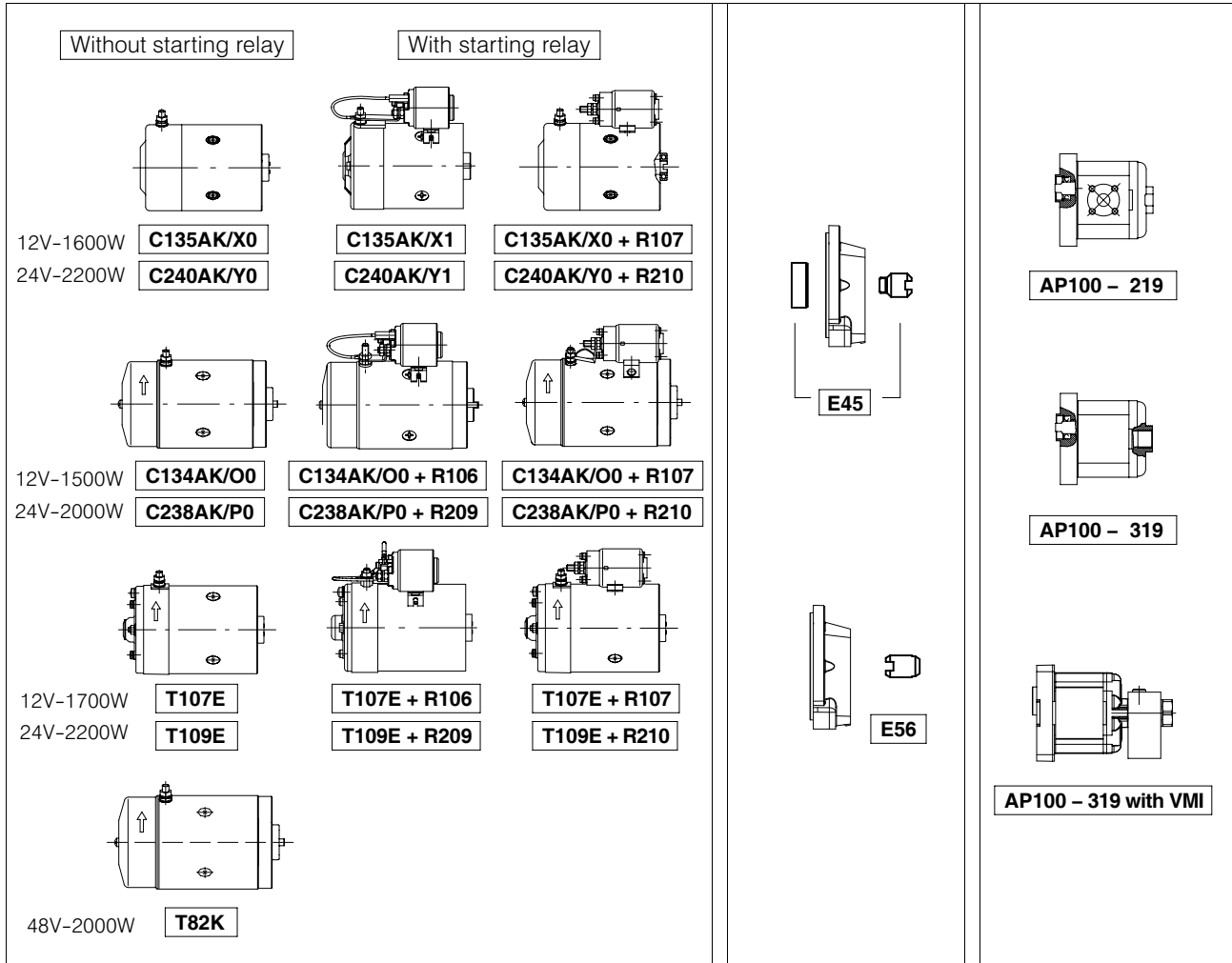
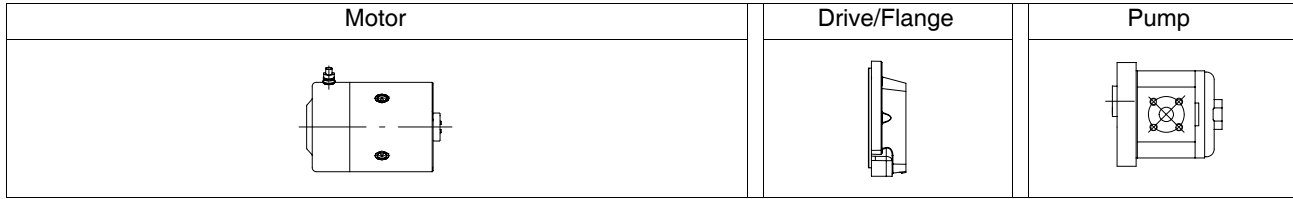

El. motor	E45	E56
C135AK/X0	●	
C135AK/X1	●	
C135AK/X0 +R107	●	
C240AK/Y0	●	
C240AK/Y1	●	
C240AK/Y0 +R107	●	
C134AK/O0		●
C134AK/O1		●
C134AK/O0 +R107		●

El. motor	E45	E56
C238AK/P0		●
C238AK/P1		●
C238AK/P0 +R107		●
T107E	●	
T107E + R106	●	
T111E	●	
T109E	●	
T109E + R209	●	
T112E	●	
T82K		●

## 10 D.C. Electric motors for group 1 pumps

Voltage	12 V	24 V
Nominal Power	1600 W	2200 W

Protection index: ..... IP44 (12 V) - IP54 (24 V)  
 Insulation class: ..... F  
 Type of winding: ..... Compound  
 Brushes kit: ..... (12/1600) 200544138022  
 ..... (24/2200) 200544138023  
 Minimum brushes length: ..... 12.5 mm (0.5 inches)

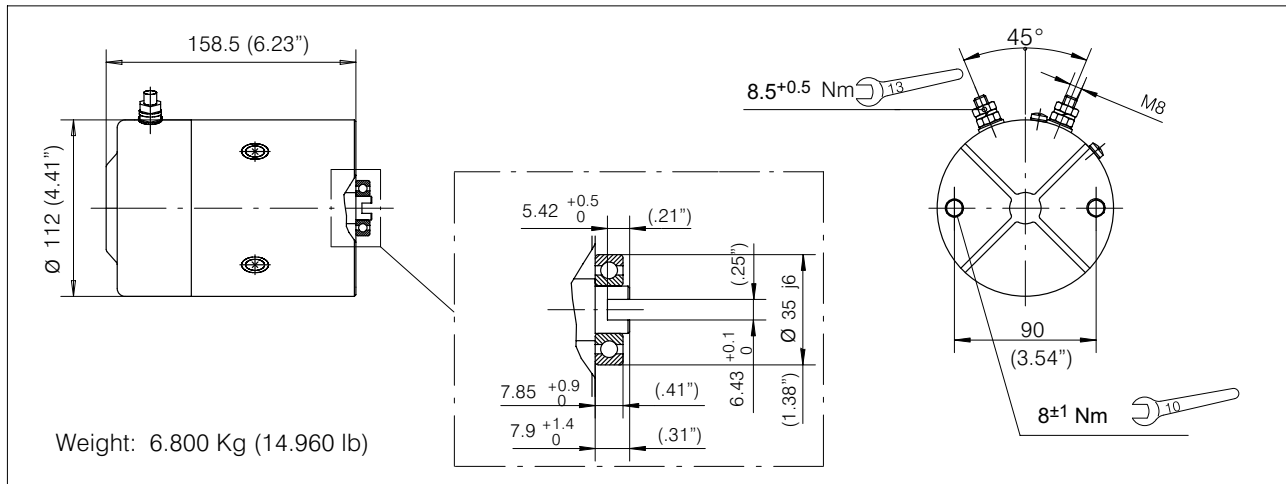

Rotation	Motor		Motor with relay			
	12 V - 1600 W	24 V - 2200 W	12 V - 1600 W	24 V - 2200 W	12 V - 1600 W	24 V - 2200 W
Right						
Type	<b>C135AK/X0</b>	<b>C240AK/Y0</b>	<b>C135AK/X1</b>	<b>C240AK/Y1</b>	<b>C135AK/X0 +R107</b>	<b>C240AK/Y0 +R210</b>
Code	200543913501	200543924001	200543913503	200543924002	200763310090	200763320090
Relay			Standard		Heavy duty	
Relay type			R106	R209	R107	R210
					Standard positions only	

### Motor mounting position

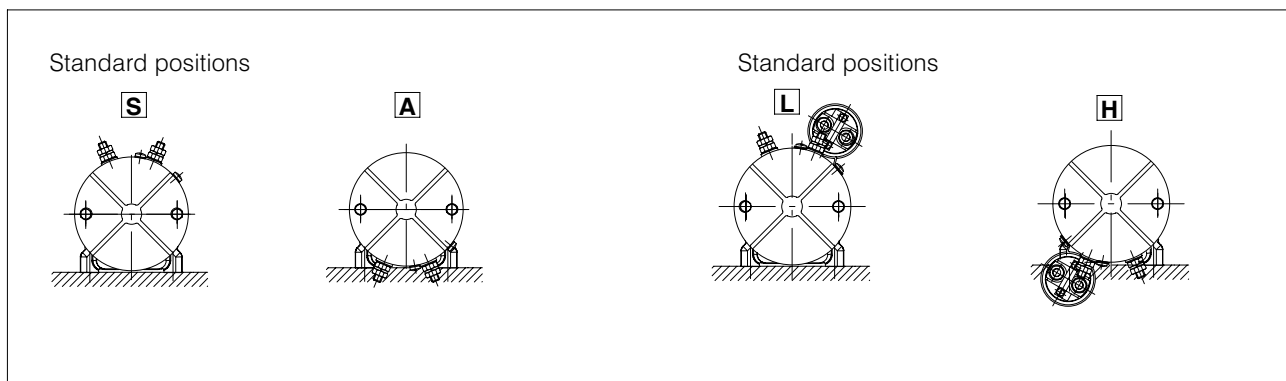

**12 V – 1600 W**

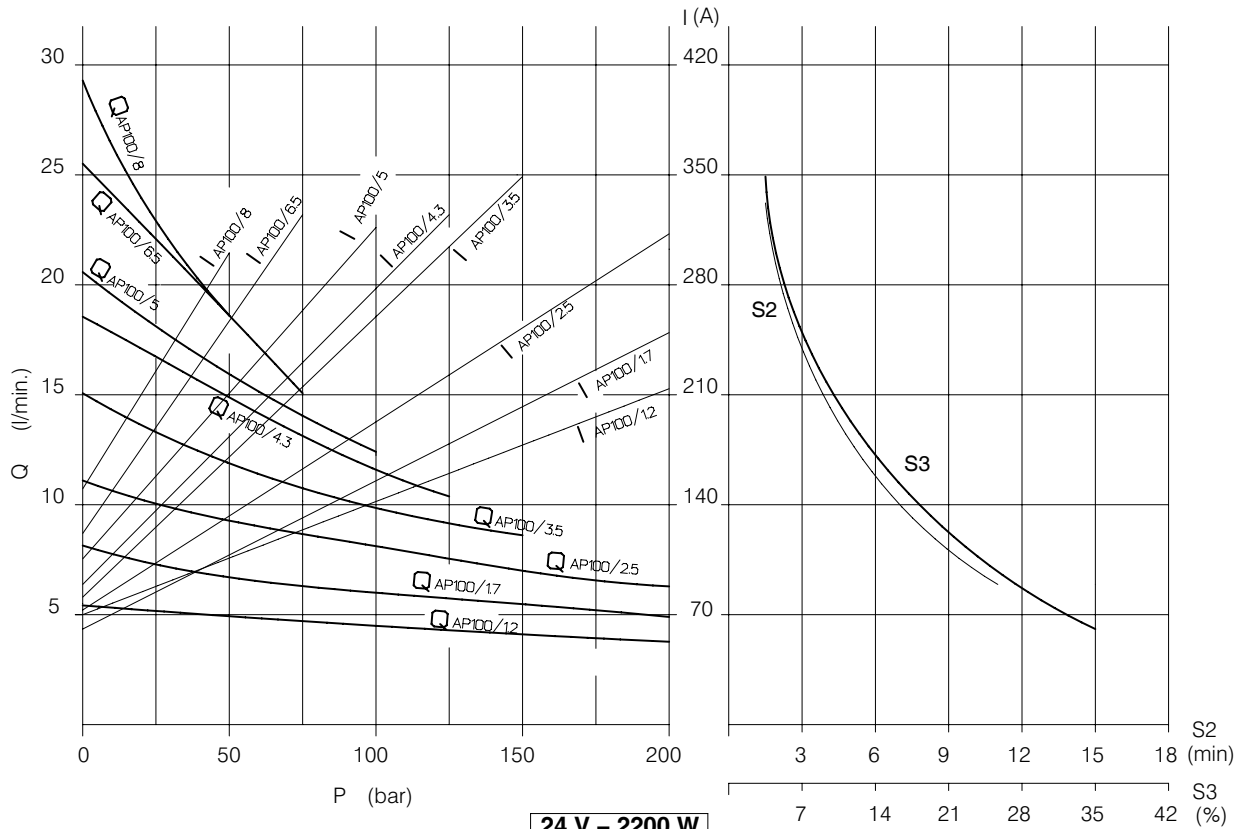

**24 V – 2200 W**

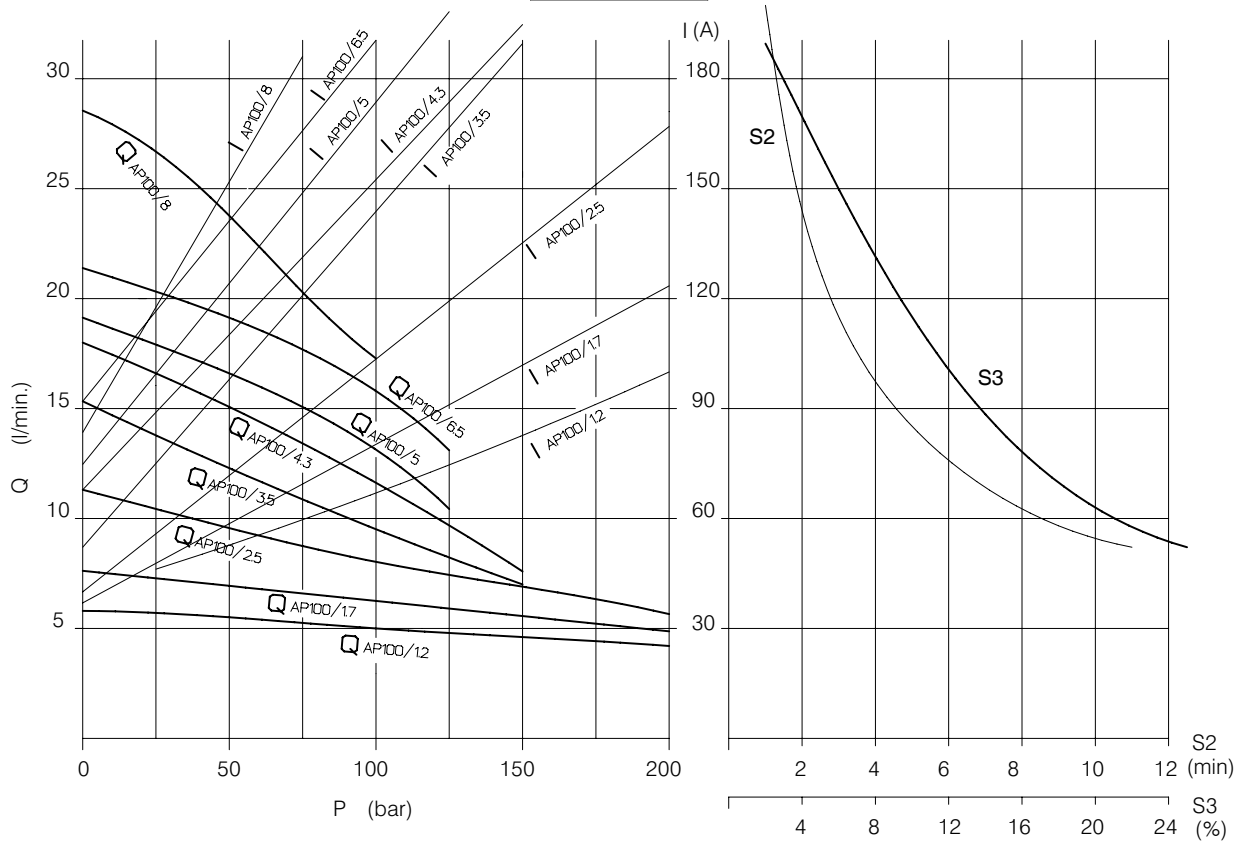

Voltage	12 V	24 V
Nominal Power	1500 W	2000 W

Protection index: ..... IP54  
 Insulation class: ..... F  
 Type of winding: ..... Compound  
 Brushes kit: ..... (12/1500) 200544138016  
 ..... (24/2000) 200544138015  
 Minimum brushes length: ..... 12.5 mm (0.5 inches)

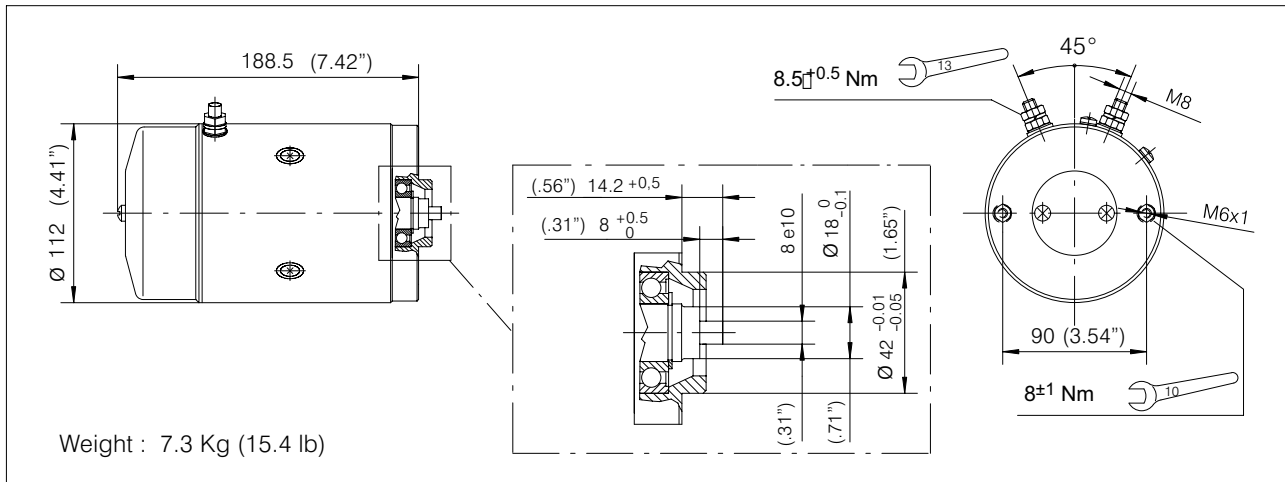

Rotation	Motor		Motor with relay			
	Right					
Type	<b>C134AK/O0</b>	<b>C238AK/P0</b>	<b>C134AK/O0 +R106</b>	<b>C238AK/P0 +R209</b>	<b>C134AK/O0 +R107</b>	<b>C238AK/P0 +R210</b>
Code	200543913416	200543923813	200763310010	200763320030	200763310030	200763320050
Relay			Standard		Heavy duty	
Relay type			R106	R209	R107	R210
					Standard positions only	

Motor mounting position

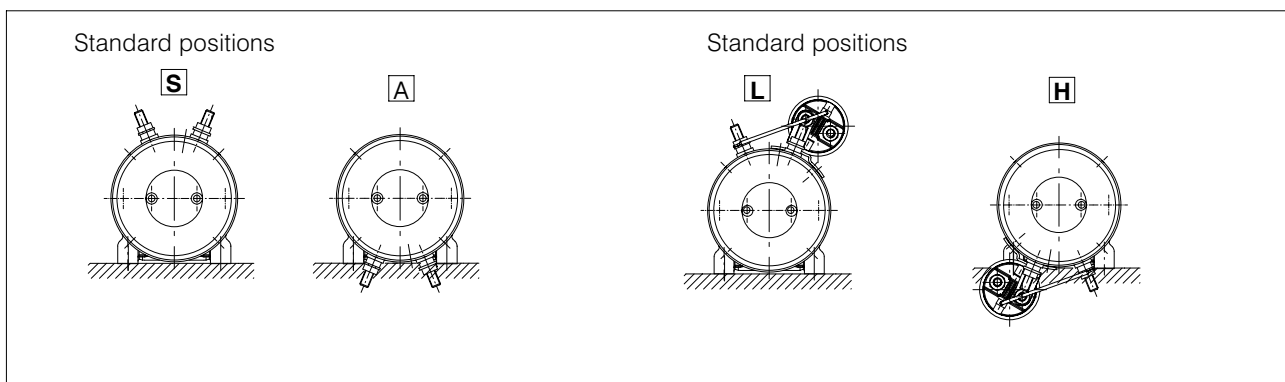

**12 V – 1500 W**

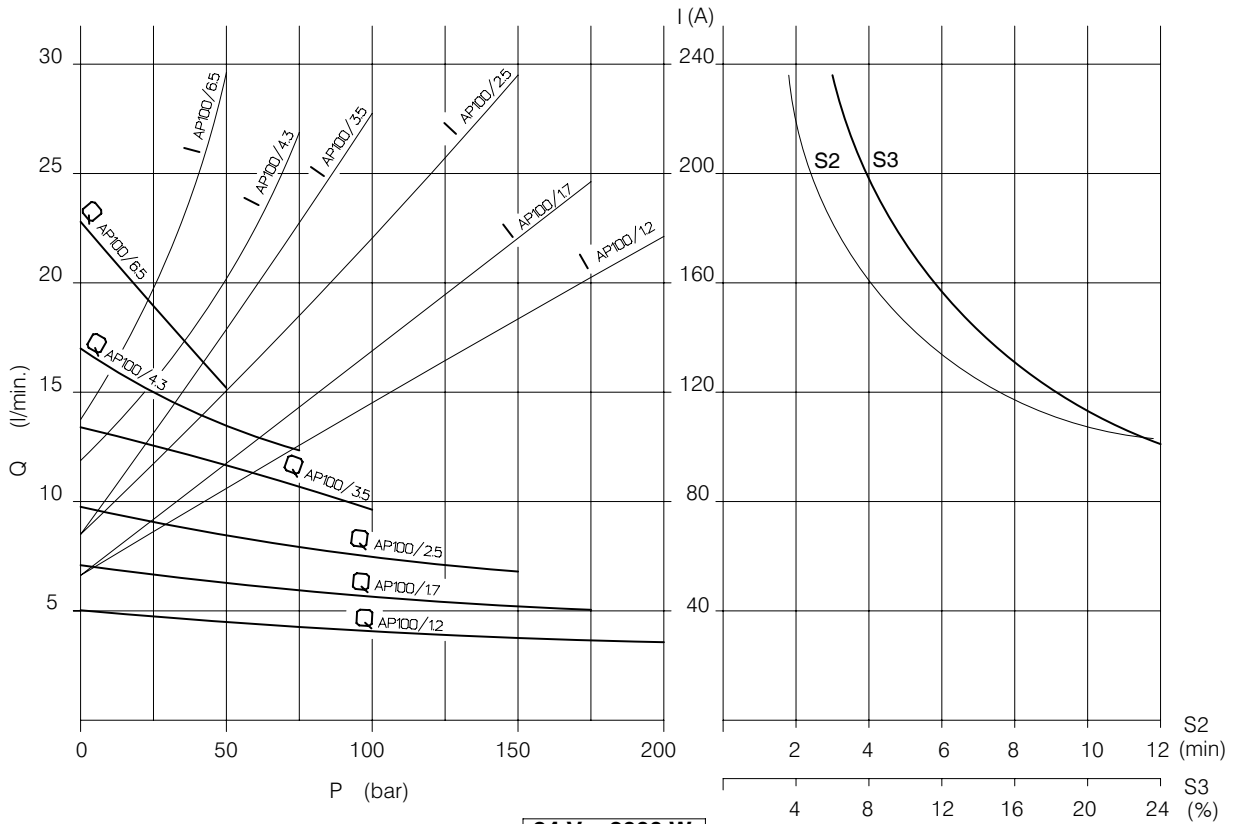

**24 V – 2000 W**

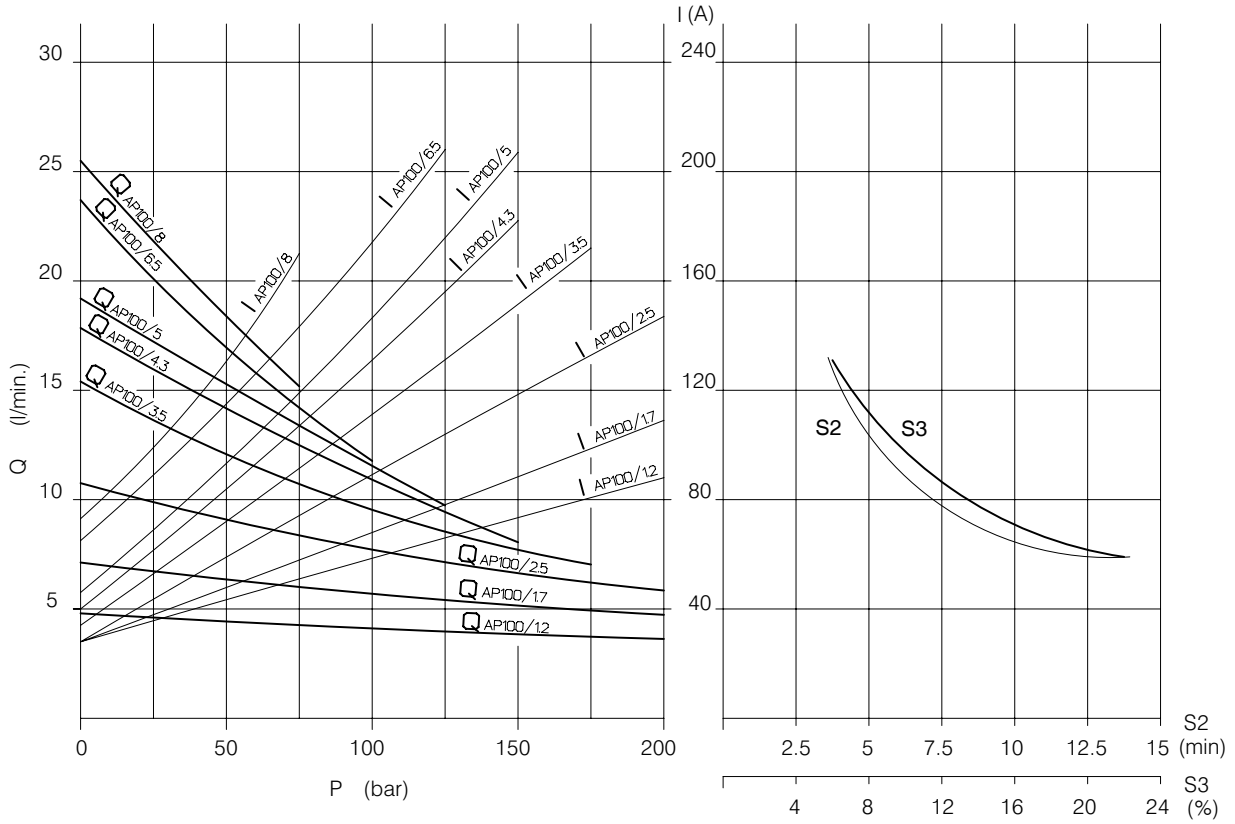

Voltage	12 V	24 V
Nominal Power	1700 W	2200 W

Protection index: ..... IP44  
 Insulation class: ..... B  
 Type of winding: ..... Compound  
 Brushes kit: ..... (12/2000-24/2500) 200544138012  
 Minimum Brushes length: ..... 5 mm (0.2 inches)

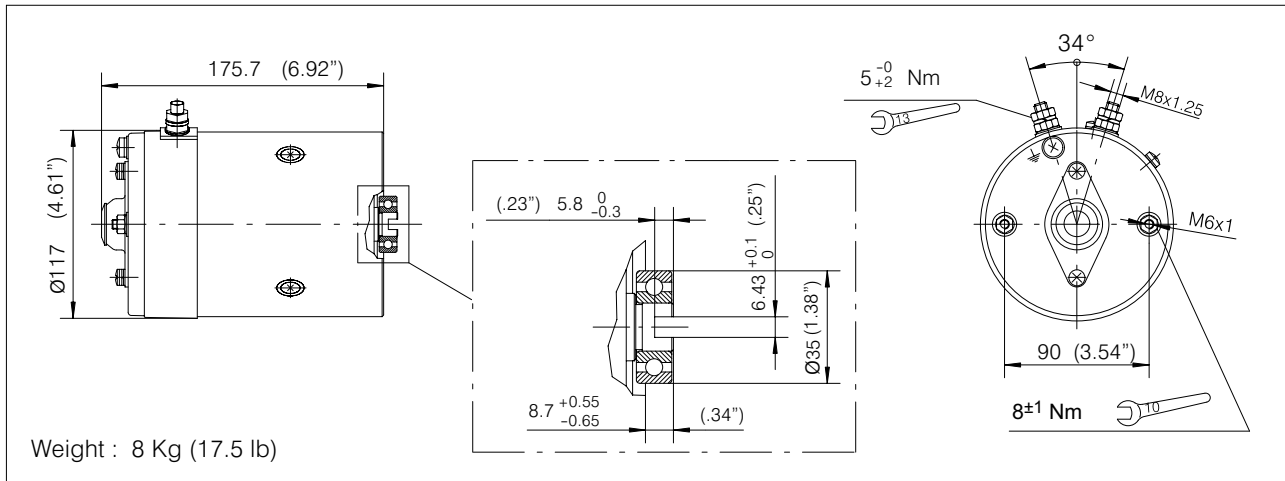

Rotation	Motor		Motor with relay			
	12 V - 1700 W	24 V - 2200 W	12 V - 1700 W	24 V - 2200 W	12 V - 1700 W	24 V - 2200 W
Right						
Type	<b>T107E</b>	<b>T109E</b>	<b>T107E + R106</b>	<b>T109E + R209</b>	<b>T107E + R107</b>	<b>T109E + R210</b>
Code	200543913806	200543924205	200763310160	200763320170	200763310190	200763320230
Relay			Standard		Heavy duty	
Relay type			R106	R209	R107	R210
					Standard positions only	

### Motor mounting position

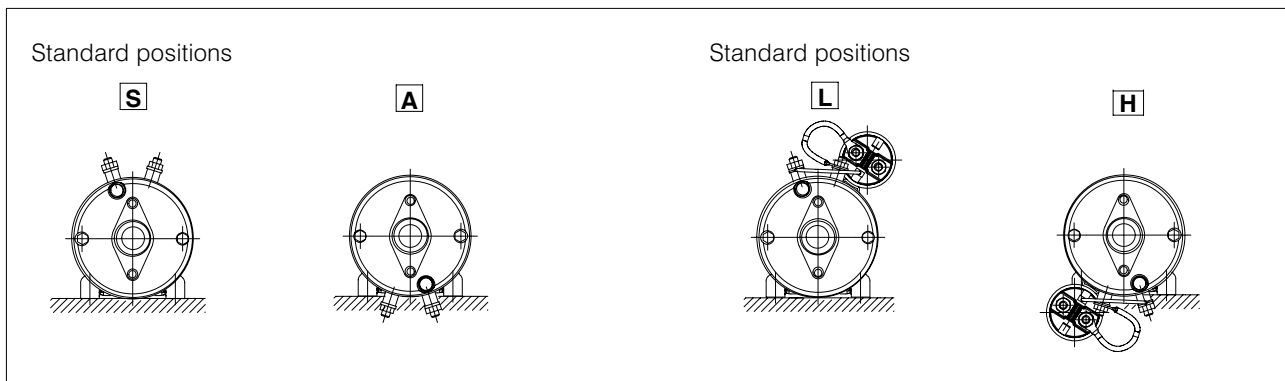

**12 V – 1700 W**

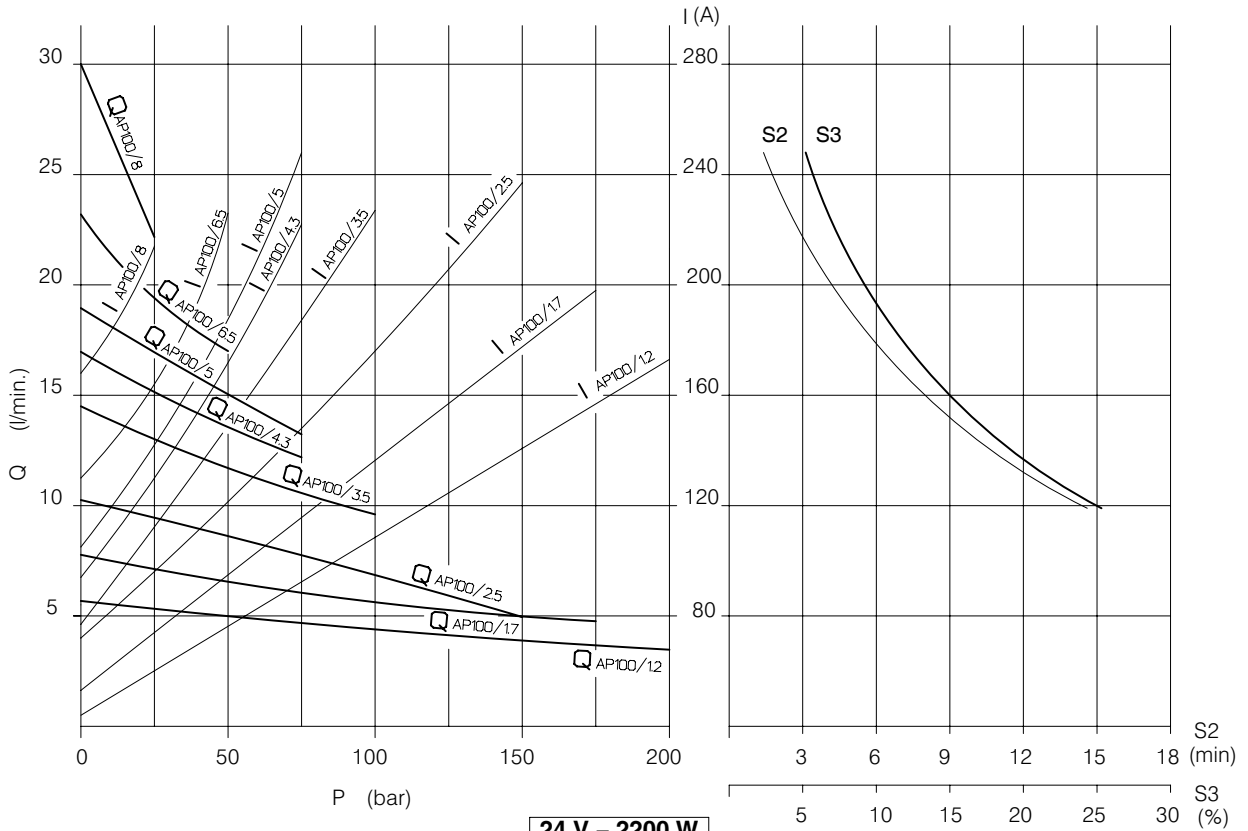

**24 V – 2200 W**

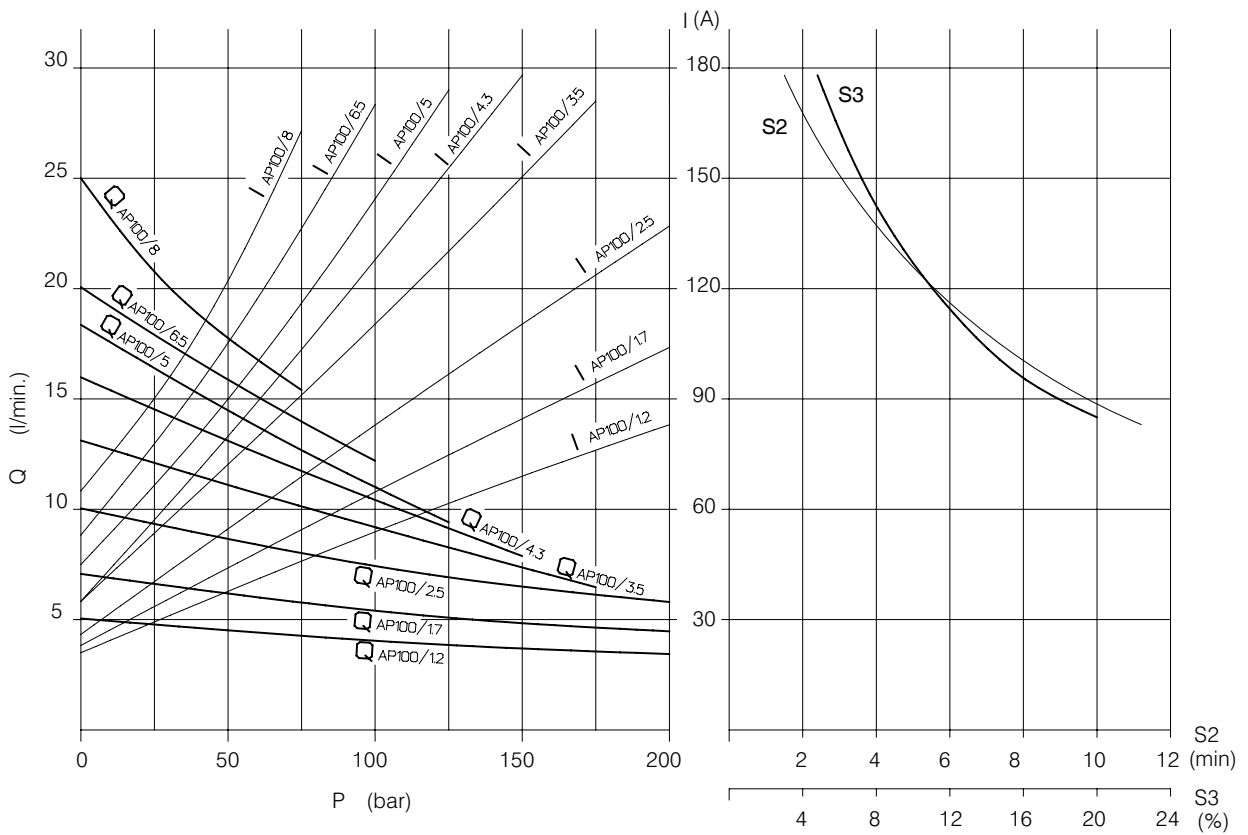

Voltage	48V
Nominal Power	2000 W

Protection index: ..... IP54  
 Insulation class: ..... F  
 Type of winding: ..... Compound  
 Brushes kit: ..... 200544138018  
 Minimum brushes length: ..... 12.5 mm (0.5 inches)

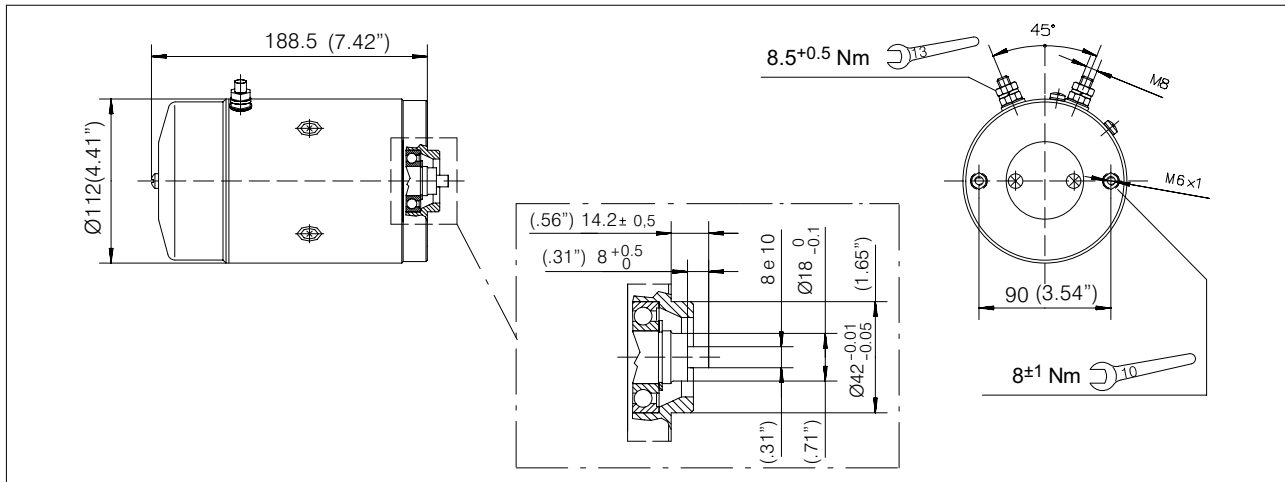

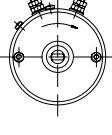
Motor	
Rotation Right	
Type	<b>T82K</b>
Code	<b>200543933803</b>
Relay	
Relay type	

**Motor mounting position**

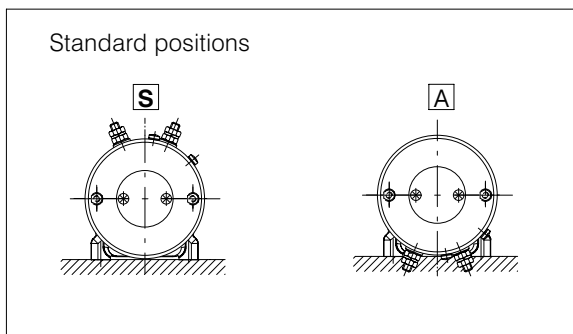

**48 V – 2000 W**

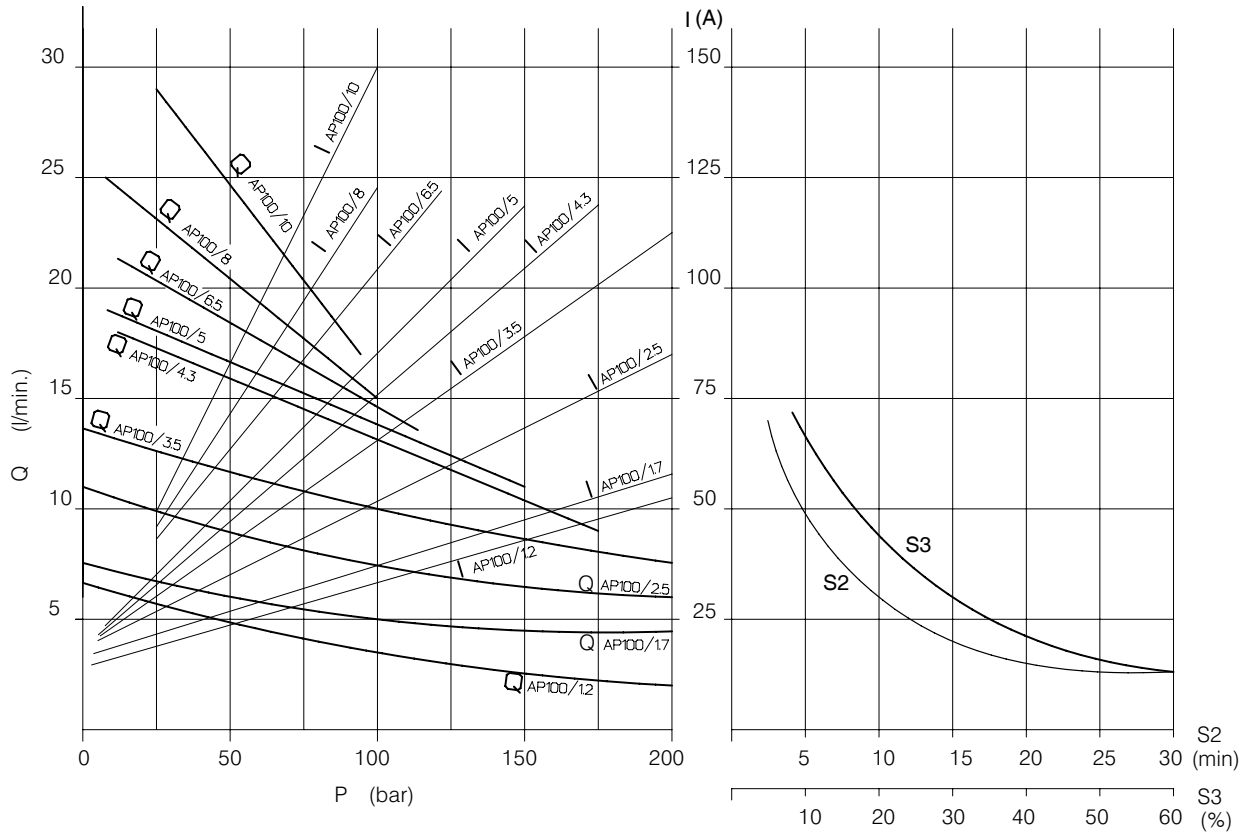

**11 Drives and connecting flange for group 1 pumps**

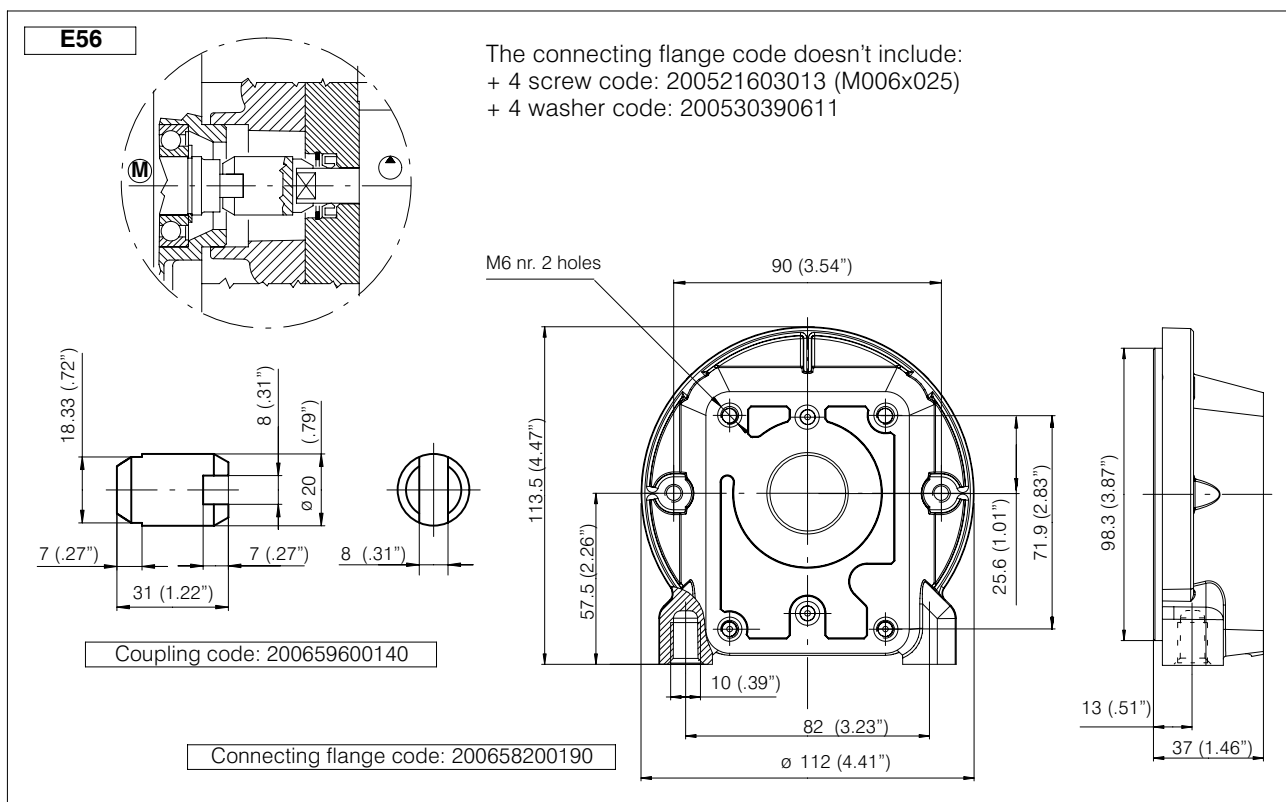
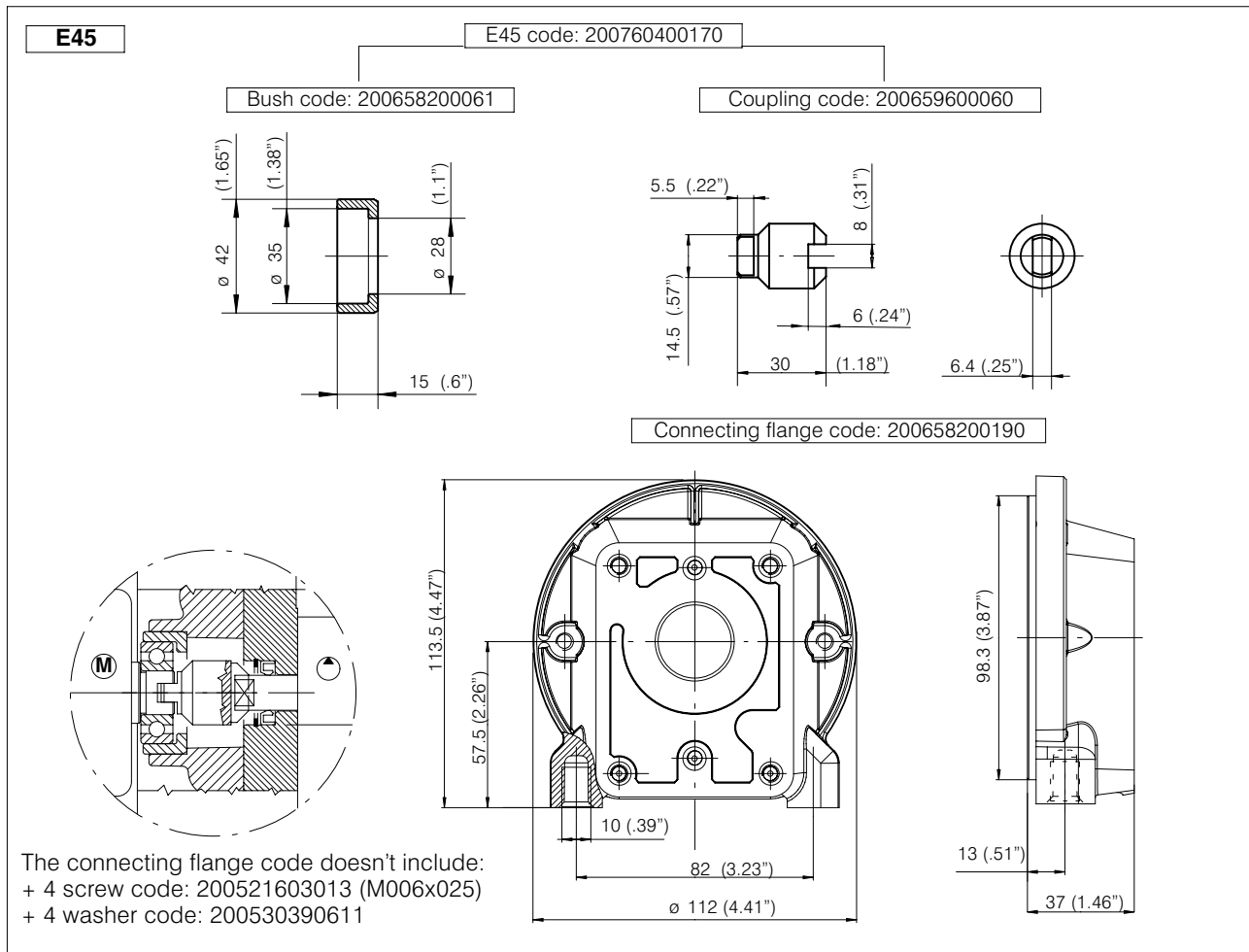

12 Group 1 gear pumps

AP100 Type	Displacement		Max. pressure						n min.		n max.	
	cm <sup>3</sup> /rev	Cu. In. P. R.	P1		P2		P3		P ≤ P1	P > P1	P ≤ P1	P > P1
			bar	P.S.I.	bar	P.S.I.	bar	P.S.I.				
AP100/1.2	1.2	.073	210	3000	250	3600	280	4000	800	1000	4500	5000
AP100/1.7	1.7	.103	210	3000	250	3600	280	4000	650	800	4500	5000
AP100/2.5	2.5	.152	210	3000	250	3600	280	4000	650	800	4500	5000
AP100/3.5	3.5	.213	210	3000	230	3300	250	3600	650	800	3500	4000
AP100/4.3	4.3	.262	210	3000	230	3300	250	3600	550	700	3500	4000
AP100/5	5.0	.305	210	3000	230	3300	250	3600	500	650	3000	3500
AP100/6.5	6.5	.396	190	2700	220	3150	240	3400	500	650	2500	3000
AP100/8	7.8	.476	180	2600	210	3000	230	3300	500	650	2500	3000
AP100/10	10.0	.610	150	2150	180	2600	200	2900	500	650	2000	2500

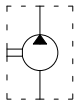

Group **AP100** Code **219**

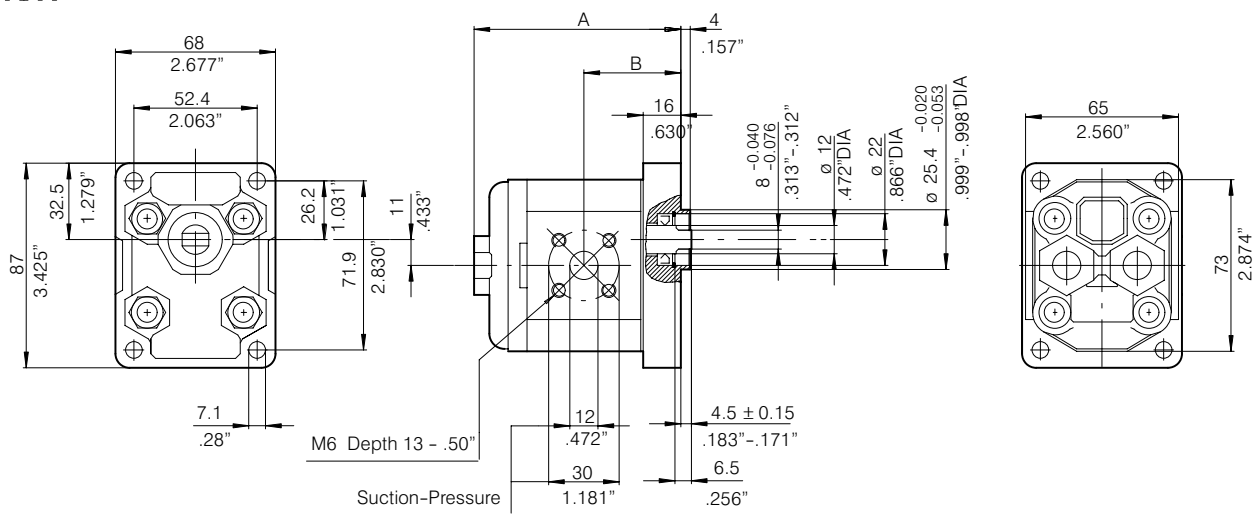

Type	Displacement cm <sup>3</sup> /rev	Dimensions				Order code Counterclockwise rotation: S
		A		B		
		mm	inches	mm	inches	
AP100/1.2	1.2	82.5	3.25	38.5	1.51	200101114306
AP100/1.7	1.7	84.5	3.33	39.5	1.55	200101214307
AP100/2.5	2.5	88	3.46	41	1.61	200101314306
AP100/3.5	3.5	92	3.62	43.5	1.71	200101414306
AP100/4.3	4.3	96	3.78	45	1.77	200101514306
AP100/5	5	98.5	3.88	46.5	1.83	200101614304
AP100/6.5	6.5	103.5	4.07	49	1.93	200101714304
AP100/8	7.8	109	4.29	52	2.05	200101814302
AP100/10	10	118	4.64	56.5	2.22	

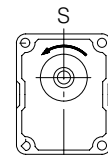

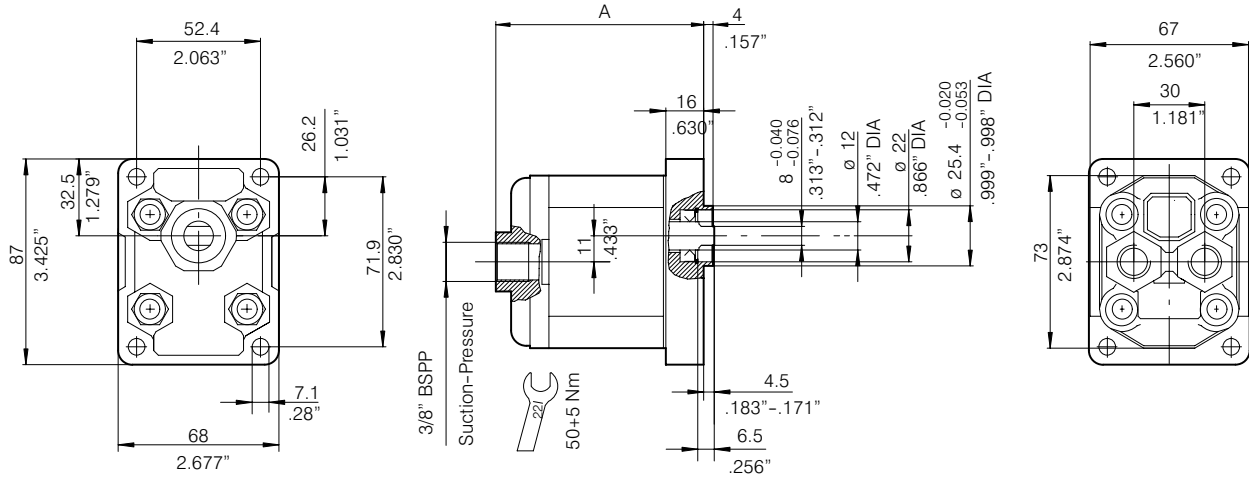
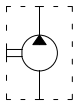

Type	Displacement cm <sup>3</sup> /rev	Dimensions		Order code Counterclockwise rotation: S
		A		
		mm	inches	
<b>AP100/1.2</b>	1.2	82.5	3.25	<b>200101114307</b>
<b>AP100/1.7</b>	1.7	84.5	3.33	<b>200101214308</b>
<b>AP100/2.5</b>	2.5	88	3.46	<b>200101314307</b>
<b>AP100/3.5</b>	3.5	92	3.62	<b>200101414307</b>
<b>AP100/4.3</b>	4.3	96	3.78	<b>200101514308</b>
<b>AP100/5</b>	5	98.5	3.88	<b>200101614305</b>
<b>AP100/6.5</b>	6.5	103.5	4.07	<b>200101714305</b>
<b>AP100/8</b>	7.8	109	4.29	<b>200101814303</b>
<b>AP100/10</b>	10	118	4.64	

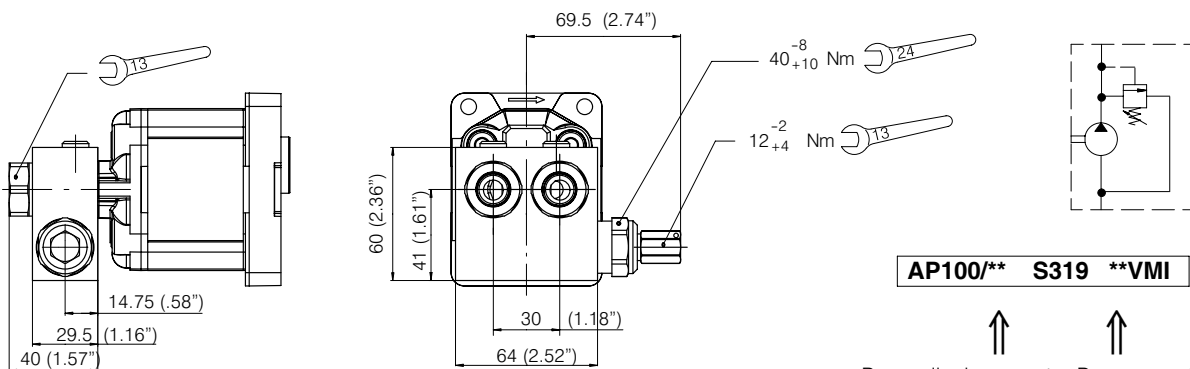
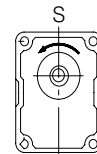

**AP100/\*\* S319 \*\*VMI**

↑ Pump displacement      ↑ Pressure setting  
ex. 15= 150 bar

Spring	Spring color	Spring code	Setting range	Standard setting	Type	Relief valve code
02		200662401470	5 - 30 bar	20 bar	<b>02VM01</b>	200787400700
06	Yellow	200662401450	30 - 95 bar	60 bar	<b>06VM01</b>	200787400720
15	Green	200662401480	95 - 210 bar	150 bar	<b>15VM01</b>	200787400740
22	Blue	200662401460	200 - 300 bar	220 bar	<b>22VM01</b>	200787400710

### 13 Components

#### 13.1 Pressed steel bracket

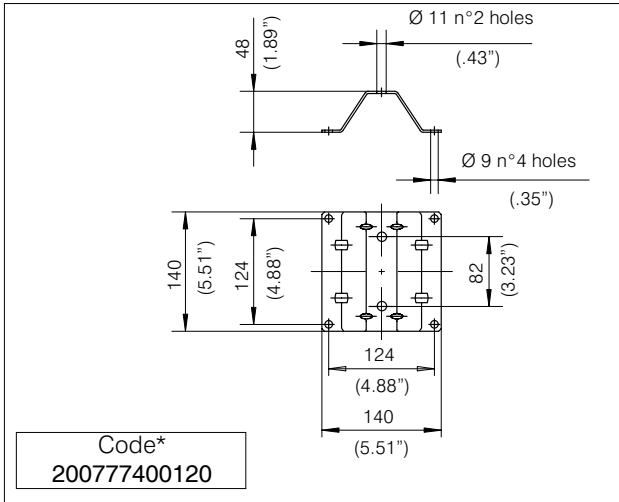

\* Supplied with screws, washers and nuts too

#### 13.2 Protective cover for D.C. motors

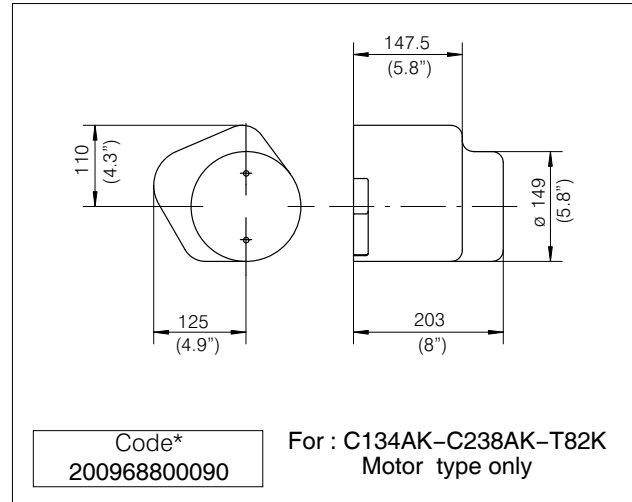

### 14 Order designation examples of Electro-Motor-Pumps

#### Group 05 E. motor without relay

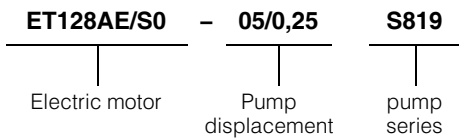

#### Group 1 E. motor without relay

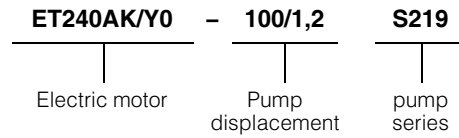

#### Group 05 E. motor with relay



#### Group 1 E. motor with relay and VMI

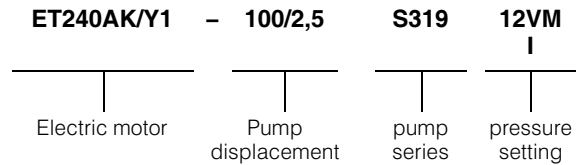

Manufacturing Month	Manufacturing year			
	2009	2010	2011	2012
January	9A	0A	1A	2A
February	9B	0B	1B	2B
March	9C	0C	1C	2C
April	9D	0D	1D	2D
May	9E	0E	1E	2E
June	9F	0F	1F	2F
July	9G	0G	1G	2G
August	9H	0H	1H	2H
September	9I	0I	1I	2I
October	9J	0J	1J	2J
November	9K	0K	1K	2K
December	9L	0L	1L	2L

Product identification plate Example

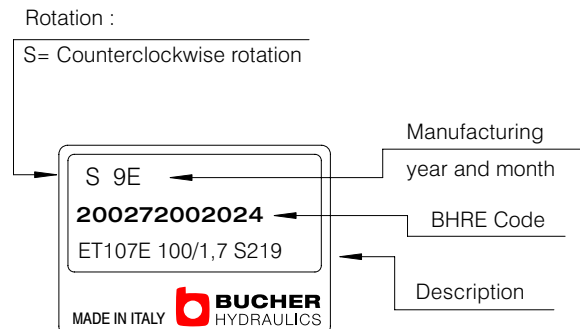



[info.it@bucherhydraulics.com](mailto:info.it@bucherhydraulics.com)

[www.bucherhydraulics.com](http://www.bucherhydraulics.com)

© 2009 by Bucher Hydraulics S.p.A., IT - 42100 Reggio Emilia.

All rights reserved.

Data is provided for the purpose of product description only, and must not be considered as warranted characteristics in the legal sense. The information does not relieve users from the duty of conducting their own evaluations and tests. Because the products are subject to continual improvement, we reserve the right to amend the product specifications contained in this catalogue.

Classification: 440.405.000