

Parolai Guards — World Leader in Machine Tool Guarding

Machine Tool Guarding at Point of Operation



Your Source for



Airline



Bensalem, PA • USA

Phone: 800-999-7378

Fax: (215) 638-1707

www.airlinehydraulics.com

Location of Offices and Branches

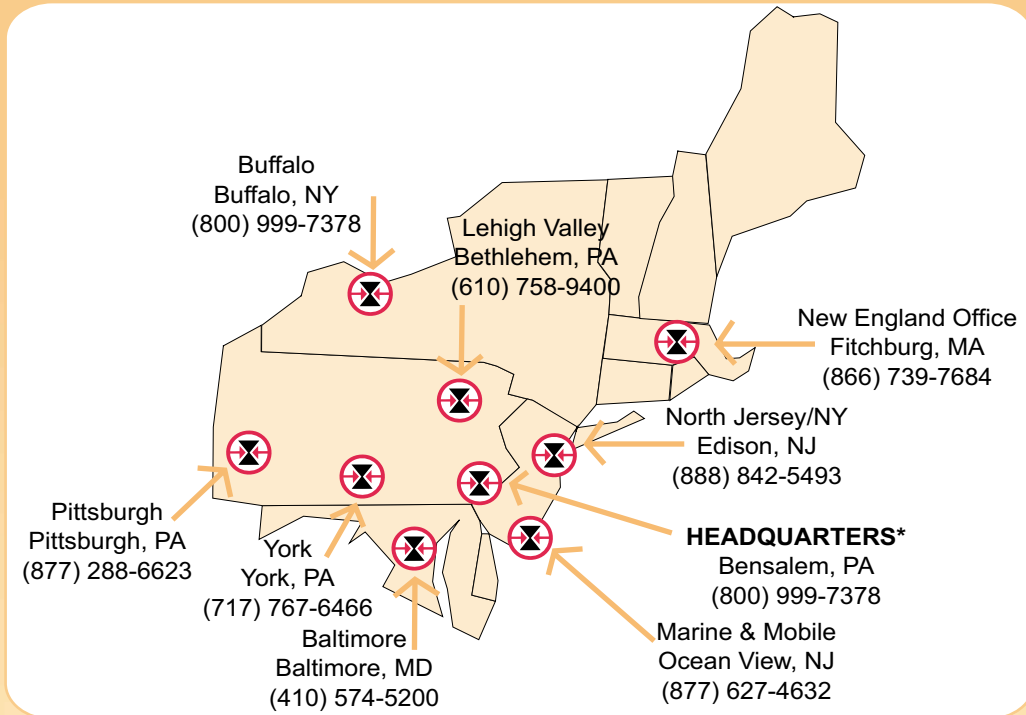

*Please direct all inquires to our Corporate Headquarters at (800) 999-7378

Airline is More than Meets the Eye!

For over 50 years, Airline has been servicing the fluid power, automation, safety and controls industries. We have learned how to listen to our customers' needs, and we have learned how to satisfy those needs.

For over a decade, we have focused on servicing the machine safeguarding needs of our customers. We have a dedicated department at Airline which supports the safety needs of our clients from on-site evaluations and mechanical 3-D design to manufacturing (kitting, full assembly, raw materials). We also provide field installation of barrier-type guarding, safety interlocks/relays, light curtains and safety mats.

Our past successes have now positioned us to service machine shops and tool & die companies with the Parolai machine tool guarding product line.

Let our safety team help you meet and exceed your safety requirements!

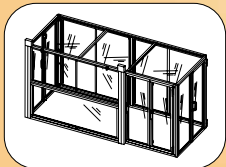

Design

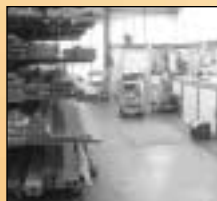

Manufacturing



Field Installation



Safety Components



Machine Tool Guarding



Phone: (800) 999-7378

Fax: (215) 638-1707

Table of Contents

Topic	Page
Introduction to Airline	2
Milling Machine Guards	4-7
Lathe Machine Guards	8-15
Drill Machine Guards	16-18
Grindstone Machine Guards	19-20
Circular Saw Machine Guards	21-23
Planing Machine Guards	24
Band Saw Guard	25
Parolai Spare and Replacement Parts	26-27
Safety Interlocking Switches	28-29
Safety Processing Devices	30-31
Price Sheet	32
Order Form	33
Machine Safeguarding Framing & Services	34
Terms and Conditions	35

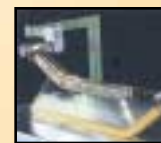
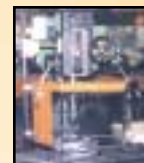
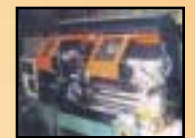

Phone: (800) 999-7378

Fax: (215) 638-1707

MILLING MACHINE GUARDS

SPINDLE GUARD



Height = 13.78 inches (350mm)
Length = 21.25 inches (540mm)

PART NUMBER
#5500 FSE (right mounting)
and
#5500 FSEG (left mounting)

- Prevents projectiles
- Does not restrict any machine activity
- Pivots horizontally and vertically
- Electrical safety interlock
- Adjustment mode with key
- Integrated fluorescent light
- Mounting kit included

MILLING MACHINE GUARDS

TABLE GUARD



PART NUMBER #4810 SE

- Total operator's protection
- Does not reduce the working area
- Door safety switches included
- Visibility combined with rigidity
- Does not limit any machine activities
- Key adjustment mode

Length = 47.24 inches (1200mm)
Width = 13.78 inches (350mm)
Height = 26.97 inches (685mm)

Length = 55.11 inches (1400mm)
Width = 15.75 inches (400mm)
Height = 26.97 inches (685mm)

Length = 62.99 inches (1600mm)
Width = 19.69 inches (500mm)
Height = 26.97 inches (685mm)

Please see the following page for the guard configuration form.

MILLING MACHINE GUARDS

TABLE GUARD CONFIGURATION FORM

Is the table front available?

Yes No

Plan View

E

a

b

f e e e e

Exist? Yes No

If not, please draw here below the extrimity of the indicated table, in plan and side views.

A	Width of the machine head	
B	Maximum movement of the machine head to the table	
C	Maximum movement of the table to the left	
D	Maximum movement of the table to the right	
E	Length of the table	

a	b	c	d	e	f	g

Make:

Type:

No:

Conventional

Yes No

C.N.C.

Yes No

**CONFIGURATION FORM
FOR
PART NUMBERS
#4810 SE**

MILLING MACHINE GUARDS

SPINDLE GUARD



PART NUMBER #8400

- Perfect visibility
- Protection at the point of incident
- 4mm standard glass
- Sheet metal 20/10
- Five points articulation



Length = 9.84 inches (250mm)
Width = 6.30 inches (160mm)
Height = 5.51 inches (140mm)

LATHE MACHINE GUARDS

CHUCK, SADDLE AND BACK APRON GUARD



PART NUMBER # 4901 SE

- CHUCK — Retractable or sliding, depending on the diameter
- SADDLE — Sliding movement on rails
- SADDLE — Width of protection: 400mm
- BACK APRON — Mounts machine frame to the turning box
- BACK APRON — Possibility to supply transparent screens (on request)
- BACK APRON — Guards rear of machine
- BACK APRON — Hatch in case of a copier

Please see the following page for the guard configuration form.

LATHE MACHINE GUARDS

Configuration form for Model #4901 SE Lathe Guard.

LATHE			
Make:	Company:		
Type:		Conventional	Yes No
N°:		C.N.	<input type="checkbox"/> <input type="checkbox"/>
		Copier	<input type="checkbox"/> <input type="checkbox"/>

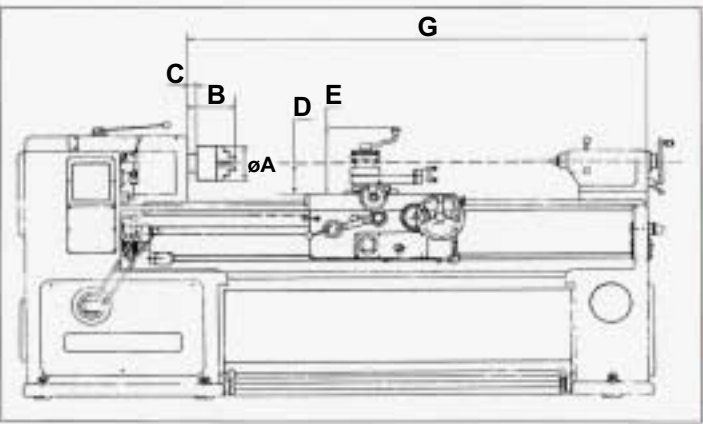
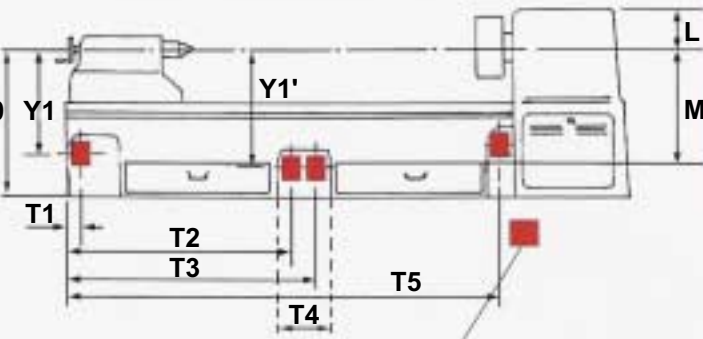
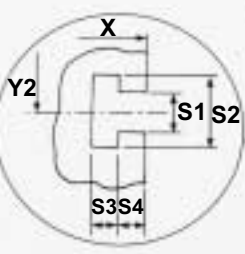
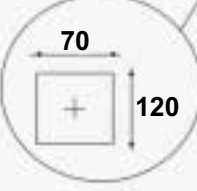
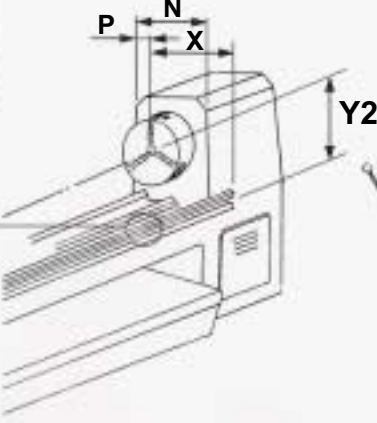
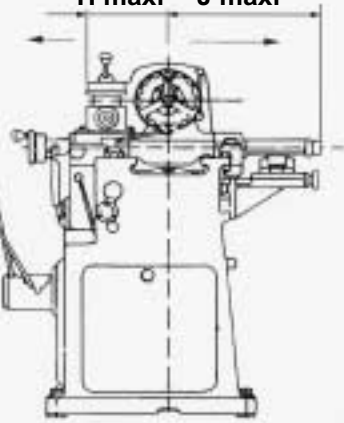
	Measurement	Dimension
ATTENTION Foresee max used free area ø	øA	
	B	
	C	
	D	
	E	
	G	
Maximum movement used for machining	H maxi	
	J maxi	
	L	
	M	
	N	
	P	
Thickness between the chuck axis and the mounting area	X	
	Y0	
	or Y1	
	Y2	
	T1	
	T2	
	T3	
	T4	
	T5	
	S1	
S2		
S3		
S4		

LATHE MACHINE GUARDS

COMPLETE LATHE GUARD

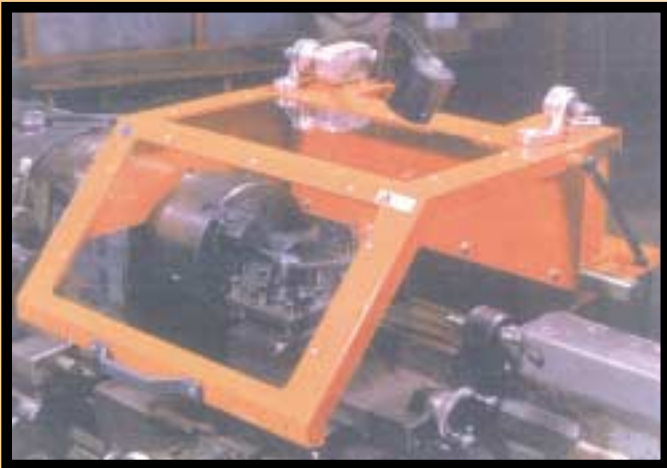

PART NUMBER

4530SE • # 4520SE
4500SE • # 4510SE
4540SE • # 4501SE

- Wide area of protection
- Encapsulating guard for the recovery of turnings and lubricants
- Shock assisted gas
- Perfect visibility of the working area (incorporated lighting)
- Electrical safety (adjustment mode is possible)

4530SE

ø = 19.69 inches (500mm)

Length = 23.62 inches (600mm)

Windows = 2 x Laminated
Tempered Glass

Lighting = Halogen, set by
European standard. Must be
converted by customer.

4520SE

ø = 19.69 inches (500mm)

Length = 15.75 inches (400mm)

Windows = 2 x Laminated
Tempered Glass

Lighting = Halogen, set by
European standard. Must be
converted by customer.

4500SE

ø = 19.69 inches (500mm)

Length = 23.62 inches (600mm)

Windows = 1 x Laminated
Tempered Glass

Lighting = Lighting, set by
European standard. Must be
converted by customer.

4510SE

ø = 19.69 inches (500mm)

Length = 31.50 inches (800mm)

Windows = 1 x Laminated
Tempered Glass

Lighting = Lighting, set by
European standard. Must be
converted by customer.

4540SE

ø = 19.69 inches (500mm)

Length = 31.50 inches (800mm)

Windows = 2 x Laminated
Tempered Glass

Lighting = Halogen, set by
European standard. Must be
converted by customer.

4501SE

ø = 19.69 inches (500mm)

Length = 45.28 inches (1150mm)

Windows = 2 x Laminated
Tempered Glass

Lighting = Halogen, set by
European standard. Must be
converted by customer.





Phone: (800) 999-7378

Fax: (215) 638-1707

LATHE MACHINE GUARDS

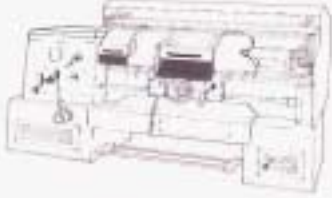
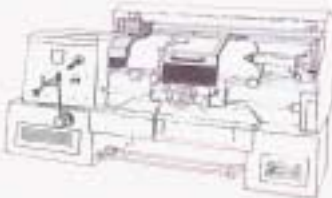
Examples of a 3-zone guard.

	<p>For additional information on model #4901SE, please see page 8.</p>	
<input type="checkbox"/> 4901 SE		<input type="checkbox"/> 4901 SE
<p>For additional information on model #4962, please see page 14.</p>		<p>Feel free to photocopy this page and check which model you'd like to receive additional information about. Please fax the page to (215) 638-1707.</p>
	<input type="checkbox"/> 4962 SE + 492D	

Specifications

4901 SE: Chuck, saddle and back apron guard. To order, configuration form on page 9 needs to be completed.

4962: Saddle protection, fixed on the back of the saddle.

Please check the appropriate box if you want to order or receive an offer. Other technical solutions are available, so please don't hesitate to contact us.

LATHE MACHINE GUARDS

LATHE CHUCK GUARD



PART NUMBER

5399SE • # 5401SE
5402SE • # 5403SE

- Assisted gas shocks
- Electrical safety system
- Adjustment mode with key
- Nitrile rubber skirt

5399SE

ø = 27.56 inches (700mm)

Length = 15.75 inches (400mm)

Windows = 2 x Laminated
Tempered Glass

5401SE

ø = 27.56 inches (700mm)

Length = 23.62 inches (600mm)

Windows = 2 x Laminated
Tempered Glass

5402SE

ø = 33.46 inches (850mm)

Length = 23.62 inches (600mm)

Windows = 1 x Laminated
Tempered Glass

5403SE

ø = 39.37 inches (1000mm)

Length = 31.50 inches (800mm)

Windows = 2 x Laminated
Tempered Glass

LATHE MACHINE GUARDS

LATHE CHUCK GUARD



PART NUMBER #5400SE

- Interchangeable transparent anti-abrasion screens
- Mounting clamp on the fixed headstock
- Electrical micro-contact safety system
- Adjustment mode with key
- Nitrile rubber skirt



ø = 19.69 inches (500mm)
Length = 10.24 inches (260mm)
Screens = 3 Polycarbonate Screens
Electrical Safety

LATHE MACHINE GUARDS

LATHE SADDLE GUARD

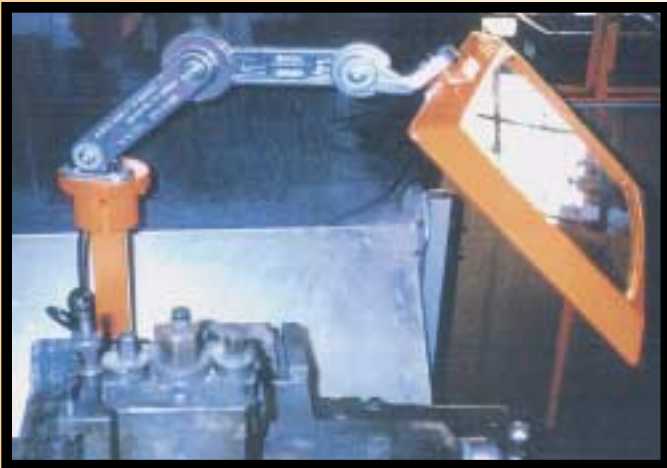

Height = 12.20 inches (310mm)
Length = 16.14 inches (410mm)

**PART NUMBER
4962**

- For conventional lathes
- Articulation on four points
- Electric safety switch

LATHE MACHINE GUARDS

LATHE CHUCK GUARD



PART NUMBER

#4921SE • #4922SE • #4923SE
 #4924SE • #4925SE • #4926SE
 #4927SE • #4928SE • #4929SE
 #4930SE • #4931SE • #4932SE
 #4933SE • #4934SE • #4935SE



- Sheet metal frame
- Epoxy painted
- Electrical safety interlock
- Adjustment mode with key
- Diameter and width of the guard according to chuck
- Nitrile rubber skirt

4921SE

Diameter = 12.6in
 Diameter = 320mm
 Length = 5.9in
 Length = 150mm

4922SE

Diameter = 12.6in
 Diameter = 320mm
 Length = 6.5in
 Length = 165mm

4923SE

Diameter = 12.6in
 Diameter = 320mm
 Length = 7.28in
 Length = 185mm

4924SE

Diameter = 12.6in
 Diameter = 320mm
 Length = 8.07in
 Length = 205mm

4925SE

Diameter = 12.6in
 Diameter = 320mm
 Length = 9.84in
 Length = 250mm

4926SE

Diameter = 13.75in
 Diameter = 350mm
 Length = 5.9in
 Length = 150mm

4927SE

Diameter = 13.75in
 Diameter = 350mm
 Length = 6.5in
 Length = 165mm

4928SE

Diameter = 13.75in
 Diameter = 350mm
 Length = 7.28in
 Length = 185mm

4929SE

Diameter = 13.75in
 Diameter = 350mm
 Length = 8.07in
 Length = 205mm

4930SE

Diameter = 13.75in
 Diameter = 350mm
 Length = 9.84in
 Length = 250mm

4931SE

Diameter = 16.93in
 Diameter = 430mm
 Length = 5.9in
 Length = 150mm

4932SE

Diameter = 16.93in
 Diameter = 430mm
 Length = 6.5in
 Length = 165mm

4933SE

Diameter = 16.93in
 Diameter = 430mm
 Length = 7.28in
 Length = 185mm

4934SE

Diameter = 16.93in
 Diameter = 430mm
 Length = 8.07in
 Length = 205mm

4935SE

Diameter = 16.93in
 Diameter = 430mm
 Length = 9.84in
 Length = 250mm

DRILL MACHINE GUARDS

ROUNDED DRILL GUARD



Height = 5.91 inches (150mm)
Cover = Polycarbonate
ø = 8.66 inches (220mm)
Pivot = Sheetmetal

PART NUMBER # 5601SEA

- Polycarbonate cover
- Adjustable height
- Electrical safety waterproof switch
- Optional additional accessory:
Universal Mounting Arm
(ref. PP01400)

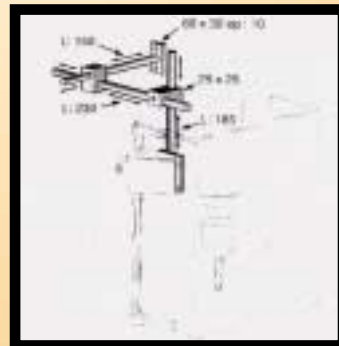

DRILL MACHINE GUARDS

SQUARED DRILL GUARD



PART NUMBER # 5602SEA

- Polycarbonate cover
- Adjustable height
- Electrical safety waterproof switch
- Optional Additional Accessory:
Universal Mounting Arm
(ref. PP01400)

Height = 12.28 inches (312mm)
Width = 3.15 inches (80mm)
Length = 9.06 inches (230mm)
Cover = Polycarbonate
Pivot = Sheetmetal



DRILL MACHINE GUARDS

RADIAL DRILL GUARD



**PART NUMBER
5611 SEA**

- Adjustable height
- Electrical safety switch
- Universal mounting arm

Height = 9.06 inches (230mm)
Length = 15.75 inches (400mm)
Width = 3.94 inches (100mm)

GRINDSTONE MACHINE GUARDS

5500 E-SERIES GRINDSTONE GUARDS



PART NUMBER # 5500 E23

- Perfect visibility
- Protection at the point of operation
- Articulation on five points
- Direct mounting

Height = 5.71 inches (145mm)
Length = 8.07 inches (205mm)



PART NUMBER # 5500 E33

- Perfect visibility
- Protection at the point of operation
- Articulation on five points
- Direct mounting

Height = 7.36 inches (187mm)
Length = 11.46 inches (291mm)

GRINDSTONE MACHINE GUARDS

5500 M-SERIES GRINDSTONE GUARDS



PART NUMBER # 5500 ME

- Articulation on five points
- Tempered glass window
- Lighting 2 x 15W

Height = 8.46 inches (215mm)
Length = 7.09 inches (180mm)

CIRCULAR SAW MACHINE GUARDS

B-SERIES GUARDS



**PART NUMBER
B 19200
STANDARD TABLE SAW**

- Protective guard prevents hand contact with the blade
- Possible adaptation to all table sizes
- Efficient protection against dust and splinters
- Connects with all existing suction systems



**PART NUMBER
B 19201
ADJUSTABLE ANGLE
SAW**

- Protective guard prevents hand contact with the blade
- Possible adaptation to all table sizes
- Efficient protection against dust and splinters
- Connects with all existing suction systems

Please see page 23 for the configuration form for these guards.

CIRCULAR SAW MACHINE GUARDS

A-SERIES GUARDS

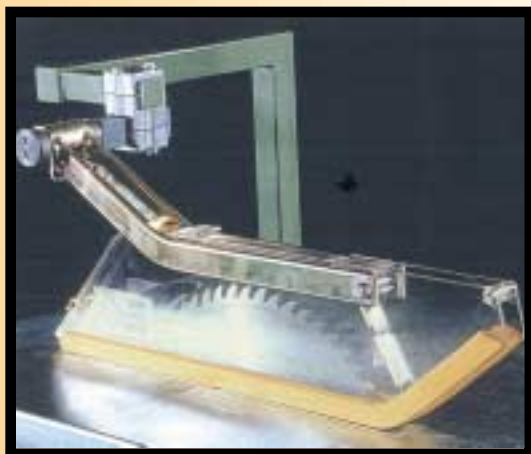

**PART NUMBER
A 19200
STANDARD TABLE SAW**

- Automatic lowering in a safety position
- Adaptation to the piece thickness
- The guard exerts a soft pressure on the piece, favoring the cut precision
- Polycarbonate guard resists shocks

Please see page 23 for the configuration form for this guard.

CIRCULAR SAW MACHINE GUARDS

Configuration form for circular saw machine guards on pages 21 and 22.

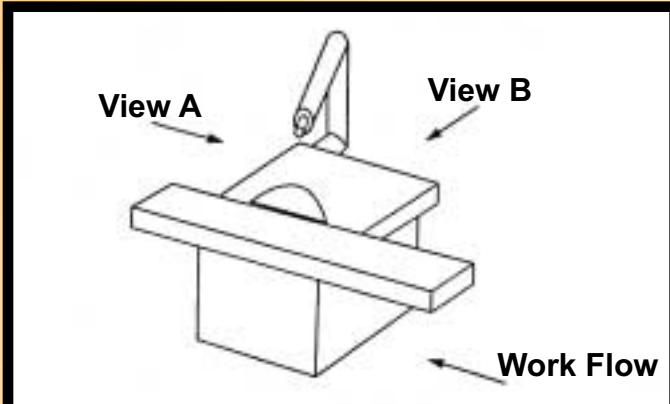

A	B	C	D	E

F	G	H	∅ Blade

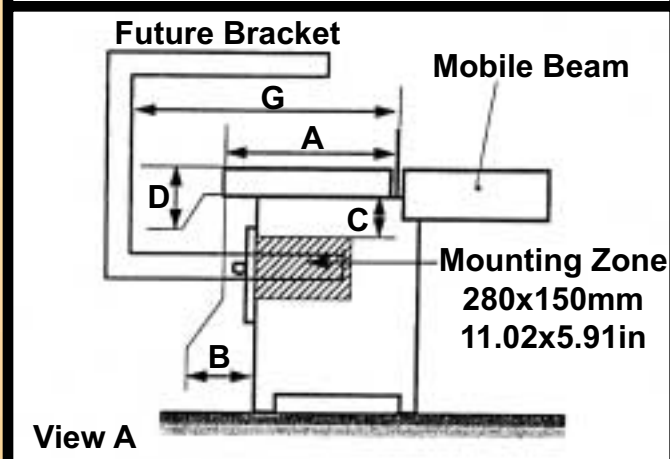

Tilting Blade?
 Yes
 No

Equipped with an inciser
 Yes
 No

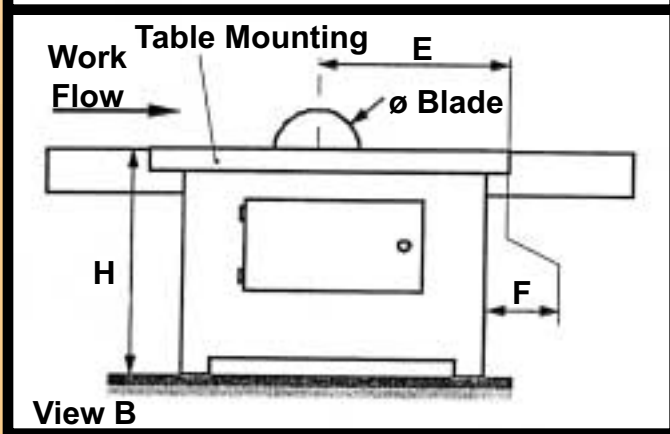

Mounting

The work area must be full and strong. If the frame sheet metal is not thick, we recommend a support packing. Please note above the requested dimensions.

We also recommend a mounting bracket on the frame. If this solution is not acceptable, please contact us for alternate solutions.

Mounting available: on ground, on wall and on ceiling.

PLANING MACHINE GUARDS

PLANING MACHINE GUARD, A19701



PART NUMBER # A 19701

- The cover automatically takes its position after the piece passes
- Guard retracts to suit product width
- Mounting adjustment (max 2.95 inches or 75mm)
- Adjustable inserting nose, vertically and horizontally

BAND SAW GUARDS

BAND SAW GUARD, AD92100



**PART NUMBER
AD91200**

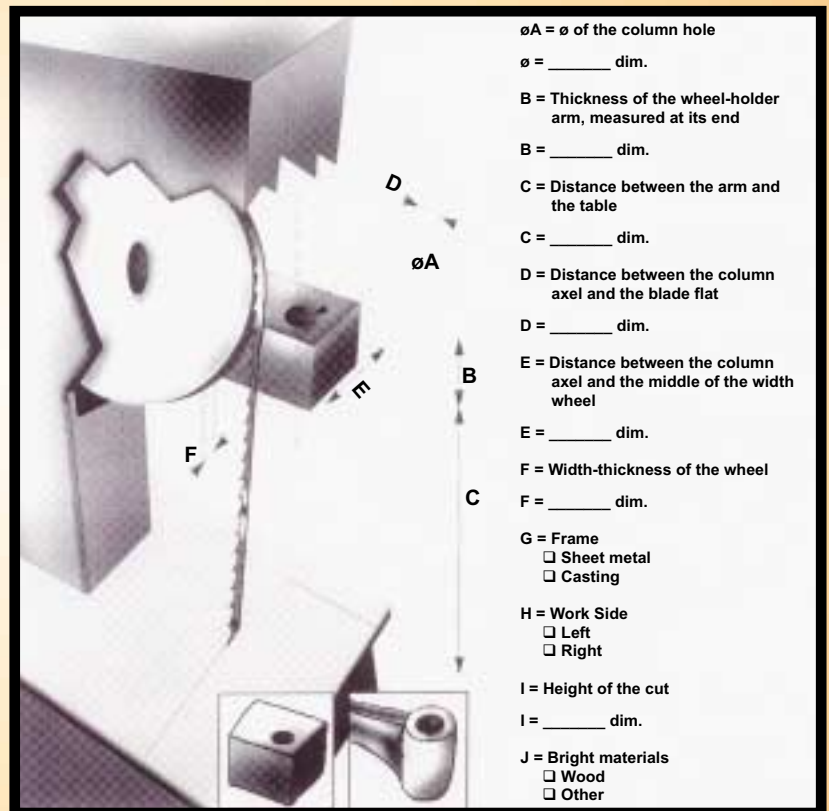

- The double system of blade guarding provides better precision
- Roller bearing guides at point of operation stabilize blade
- Excellent visibility on the cut line
- Instantaneous safety by the lever movement (without tightening and unjamming)
- Easy dismantling and reassembling of the blade — universal mounting system



PAROLAI SPARE & REPLACEMENT PARTS



**PART NUMBER
12856**

- Brackets and steel tube



**PART NUMBER
12853**

- Brackets and steel tube and command box with key



**PART NUMBER
12726**

- Electrical safety



**PART NUMBER
12855**

- Command box with key



**PART NUMBER
5217**

- Elastomer mud guard
- L = 250mm x H = 230mm
- L = 9.84in x H = 9.055in

PAROLAI SPARE & REPLACEMENT PARTS



PART NUMBER # PERCEUSES 5600

- PET screen 4mm, direct fixing on chuck
- L = 140mm x H = 150mm
- L = 5.51in x H = 5.906in



PART NUMBER # 5500 L

- Mounting Handle: 5500 A and B



PART NUMBER # UNIVERSEL 5500LM

- PET screen, magnetic block, horizontal and vertical adjustment
- L = 300mm x H = 300mm
- L = 11.81in x H = 11.81in



PART NUMBER # 12929

- Adjustable mounting model PP 12928, S.E. compatible



PART NUMBER # 12910

- Articulated arm for model PP 12928, S.E. not compatible

SAFETY INTERLOCKING SWITCHES



STI Key Interlock Switch

- Basic key-type interlock switch



STI Locking Safety Switch

- Solenoid locking safety interlock switch



STI E-Stops

- Lifeline rope pull E-Stop switch



STI 'SR' Safety Relays

- SR series of category 3 safety relays

Please call us for a complete catalog of all our machine safeguarding solutions.

SAFETY INTERLOCKING SWITCHES



Schmersal AZ-Series Key Interlock Switches

- Basic key-type interlock switch



Schmersal AZM-Series Locking Interlock Switches

- Solenoid locking safety interlock switch



Schmersal TE SZ-Series Hinge Switches

- Safety rated hinge switch



Schmersal AZR, SRB, AES-Series Safety Relays

- Series of category 3 safety relays

Please call us for a complete catalog of all our machine safeguarding solutions.

SAFETY PROCESSING DEVICES



PART NUMBER # STI Light Curtains

- Full family of light curtains available in a variety of sizes for a variety of applications

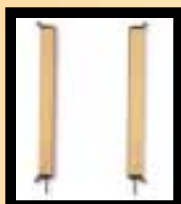

STI MS-Series Light Curtains

- Light curtain series for 2 box system



STI MC-Series Light Curtains

- Light curtain with din rail mounted controller



STI UM-Series Universal Safety Mat

- Universal safety mat



STI BeamSafe III

- Single beam safety sensor

Please call us for a complete catalog of all our machine safeguarding solutions.

SAFETY PROCESSING DEVICES



Safety Ross Air Dump Valve

- 3-way and 4-way, category three air dump valves and L-O-X manual lockout valves



Orange Peel Guards

- Rotating shaft guards
- Very flexible

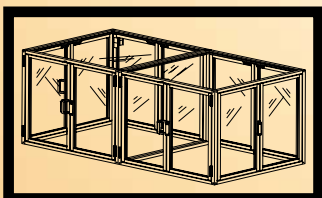

Turnkey Safety Enclosures

- Bosch structural aluminum framing
- Field design support
- 3-D AutoCAD drawing
- Manufacturing and field installation
- Application assistance

Please call us for a complete catalog of all our machine safeguarding solutions.

MODULAR SAFEGUARDING FRAMING AND SERVICES

Tap the resources of our \$1 million BOSCH extruded aluminum framing structure product line for your next safety enclosure!

Airline's Service Capabilities include...

- Raw Material 24-Hour delivery of our BOSCH product line and assembled components.
(ex. polycarbonate panels, wire mesh panels, etc.)
- Kitting Pre-machined kits, ready for your assembly, with full documentation.
- Assembled Fully assembled units, with all necessary documentation, ready for your installation.
- Field Installation Our field service technicians travel to your facility to install your safety enclosure, including performing all necessary wiring. 100% turnkey operation.

Always Keep in Mind...

- On-site design support is available. Airline's Application Engineers provide a conceptualized sketch of unit while in the field.
- Design group support is available. Our design group draws 3-D AutoCAD design layouts so you will see a detailed design before your order is even placed with us.

From
3-D CAD
Design

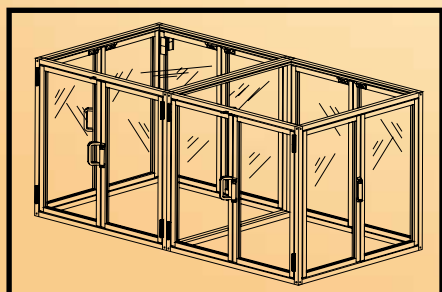

To Full
Installation
at Your
Facility



Airline
Will
Meet
Your
Needs!



Phone: (800) 999-7378

Fax: (215) 638-1707

CORPORATION

TERMS AND CONDITIONS OF SALE

IMPORTANT: Prices quoted apply to the quantity and to the delivery schedule Specified. Unless accepted within thirty (30) days from date hereof, this quotation shall automatically expire. The quotation may not be accepted in part.

1. Prices: The price of any article scheduled for shipment on a date beyond a period of 90 days from the date of Seller's quotation or, if formal quotation has not been made, from receipt of Buyer's order, is subject to increase or decrease by Seller unless otherwise agreed to in writing. Prices are F.O.B. Origin, Seller's manufacturing plant or branch unless Seller otherwise specifies. Additional services are subject to charge at Seller's standard rates.

Payment shall not prejudice claims on account of omissions or shortages in shipment, but no such claim will be allowed unless made within 30 days after receipt of shipment by Buyer. Prices of electric motors and other accessory components are not guaranteed to Seller by the manufacturer and are subject to escalation. Therefore, Seller's prices are subject to adjustment to reflect costs of electric motors and/or other accessory components in effect as the time of shipment. Prices include ordinary packing only.

2. Delivery: Unless Seller otherwise specifies, delivery will be made F.O.B., Seller's manufacturing plant or branch and title and risk of loss shall pass to Buyer at that point. Seller shall have the right to choose means of transportation and to route shipments when specific instructions are not included with Buyer's order. Seller shall have no liability whatsoever, nor shall this order be subject to cancellation, for delay in delivery due to act of God or civil or military authority, fire, labor disturbance, war, insurrection of riot, failure of or delay in transportation, unusually severe weather, default of a supplier or subcontractor or due to any other cause beyond Seller's reasonable control. In the event of delay for any such cause, the specified delivery date shall be extended for a reasonable length of time, but not less than the period of delay.

3. Terms of Payment: Terms of payment shall be, subject to credit approval, net 30 days.

4. No allowance shall be made to Buyer for any transportation, labor charges or parts, adjustments or repairs, or any other work, unless such charges are authorized in advance by Seller. Seller shall in no event be liable for special or consequential damages. If an article is claimed to be defective in material or workmanship or not to conform to specifications, Seller, upon notice promptly given, will either examine the article at its site, or issue shipping instructions for return to Seller. The warranties shall not extend to any article or parts thereof which have been installed, used or serviced, otherwise than in conformity with Seller's applicable specifications, manuals, bulletins or information, or, if none, which shall have been subjected to improper installation, misuse or neglect. The warranties shall not apply to any articles or parts thereof furnished by Buyer or acquired from others at Buyer's request and/or to Buyer's specifications. The foregoing limitations on Seller's liability in the event of breach of warranty shall also be the absolute limit of Seller's liability in the event of Seller's negligence in manufacture, installation or otherwise, with regard to the articles covered hereby, and at the expiration of the period as above stated with regard to warranties, all such liabilities shall terminate.

5. Taxes: Prices do not include any present or future federal, state or local sales, use, excise, manufacturing, processing or importation tax, or and other tax or charge, that is or may be imposed on the articles or services covered hereby or on subsidiary articles or material incorporated therein. Any such taxes or charges will be added to the invoices as separate items, unless appropriate exemption certificates are furnished to Seller.

6. Compliance With Laws: Seller to the best of his knowledge and belief, is complying with all state and federal laws, orders and regulations applicable to the manufacture of the articles ordered.

7. Partial Shipments: Seller reserves the right to make and to invoice for partial shipments of completed articles.

8. Cancellation and Changes: Orders are not subject to cancellation, complete or partial, without Seller's written consent. Any reduction in quantities ordered shall constitute a partial cancellation subject to this clause. If any change causes an increase in the cost of or time required for the performance of any work under the order, an equitable adjustment will be made to the price or delivery schedule, or both. Where Seller consents to cancellation, settlement will be made on the following basis: Buyer will pay to Seller, upon delivery, the full purchase price of all articles completed at the time Seller agrees to cancellation and, if Seller elects to complete any part or all of the articles scheduled for delivery within 30 days from such time, the full purchase price of all such articles so completed, and Buyer will further pay to Seller a percentage of the purchase price of all other articles equivalent to the percentage of completion thereof as determined by Seller's normal cost accounting methods. Buyer will also pay the full unamortized costs of materials, dies, tools, patterns, and fixtures, made or contracted specifically for Buyer's order. Invoices for all cancellation charges are payable promptly upon presentation. If within 60 days from the presentation of such invoice Buyer does not instruct Seller as to the disposition of the material, etc., arising from the cancellation, Seller may sell the same, crediting Buyer for the proceeds. Buyer will also pay the reasonable costs and expenses incurred by Seller in making a settlement hereunder and in protecting property in which Buyer has an interest. Seller will defer manufacture or delivery of any articles only if and to the extent agreed to in writing.

9. Defaults: If Buyer shall fail to pay promptly when due any sum owing to Seller or to perform any agreement under this order or under any other order heretofore or hereafter placed with Seller or if Buyer shall be adjudicated bankrupt or insolvent or shall make an assignment for the benefit of creditors or if there shall be instituted by or against Buyer any proceeding under any bankruptcy, reorganization, arrangement, readjustment of debt or insolvency law of any jurisdiction or for the appointment of a receiver or trustee in respect of any of Buyer's property and, if any such proceeding shall be instituted against Buyer, it shall not be dismissed within 20 days, or if Seller shall reasonably believe that Buyer is unable to meet Buyer's debts as they mature, then, and in any such event, Seller may, in addition to exercising any or all other rights that Seller may have, require payment of cash upon delivery, and Seller may, upon written notice to Buyer at any time, terminate all Seller's obligations under any one or more of such orders. Upon termination pursuant to this clause, Buyer shall thereupon become obligated to pay the same sum in respect to each such order as if such order had been cancelled by Buyer with Seller's consent and settlement had been made on the basis set forth in Paragraph 9 of these Terms and Conditions.

10. General: The provisions of the quotation or acknowledgement form to which this page is attached, including all of the terms and conditions on this page, shall, unless otherwise specifically agreed to by Seller in writing, be the sole terms and conditions governing any purchase and sale contract entered into pursuant to such quotation or acknowledgement. No modification of or addition to or waiver of any of the terms and conditions hereof will be effective unless agreed to in writing by Seller.



Machine Tool Guarding at Point of Operation

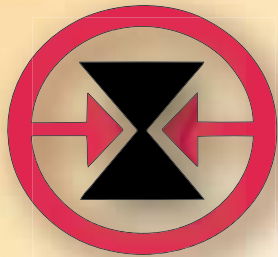

Airline

Your Source for



Bensalem, PA • USA
Phone: 800-999-7378
Fax: (215) 638-1707
www.airlinehydraulics.com