

Ceram™ 4-way Pneumatic Directional Control Valve

Tough enough to survive, no matter where in the world you send it.

The secret's a ceramic seal.

Inside the valve a pair of sliding ceramic plates form a nearly perfect, almost indestructible seal. The near diamond hard plates wipe themselves clean, shrugging off ingested dirt that destroys ordinary valves. The ceramic plates are warranted for the life of the valve.

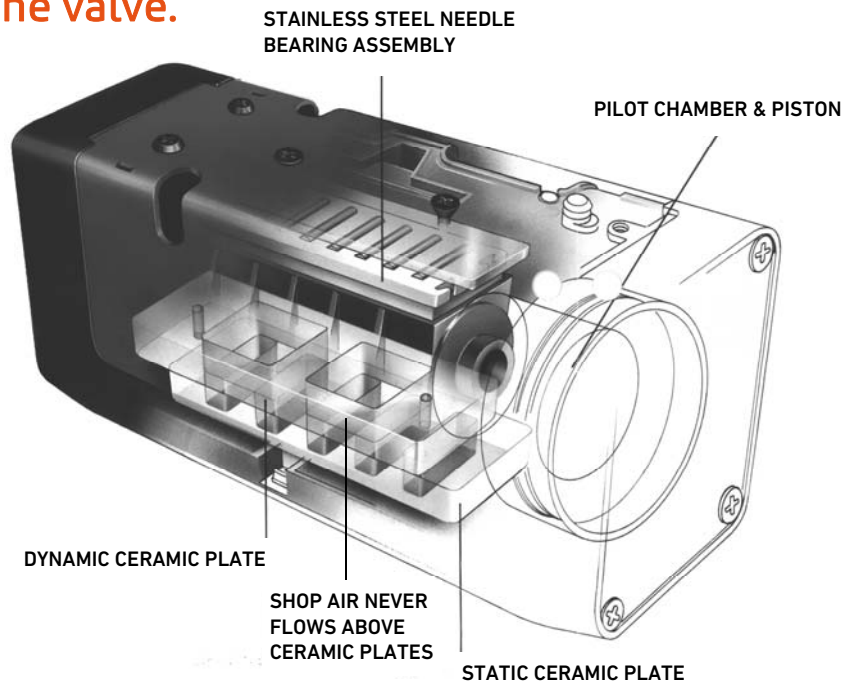

✓ Extended life

Years of proven field service with Ceram valves verify an anticipated life of 150 million cycles even under adverse conditions. The ceramic plates are warranted for the life of the valve.

✓ Just as tough with no lubrication

The Ceram valve is pre-lubed with grease. Its unique ceramic plate wiping action prevents wear even without line lubrication.

✓ World standard ISO mounting

ISO 5599/1 mounting dimensions mean that wherever you send it, it's completely interchangeable with other ISO valves anywhere in the world.

✓ Standard electrical connections

The solenoid versions operate with either AC 50 or 60 HZ service or DC voltages, using continuous duty plug-in solenoids with DIN 43 650 connectors. Lighted or non-lighted connectors are options. The Ceram valve meets NEMA 4 electrical specifications.

✓ Complete offering

Four basic valve sizes ISO 1 through 4 with subbases and manifolds available for 1/4" through 1" in NPT or ISO G(BSPP) ports. Manifolds can be end or bottom ported with no special tie rods. Models include single or double solenoid, and single or double air pilot. Solenoids can be either internal or external pilot.

Complete offering

Ceram™ valves fit the job. Choose the valve model that's right for your application. Ceram offers lots of choices other than the four ISO sizes and solenoid vs. air pilot operation. You can have two- or three-position (closed center or exhaust open center) operation, even dual-pressure and vacuum operation if needed.

BOTTOM & END PORTED MANIFOLD



Available for sizes 1 to 4.
(ISO size 1 shown)

CERAMIC SLIDING PLATES



Warranted for the life of the valve.
Near diamond hardness.

EXPLOSION PROOF SOLENOID OPERATOR



Available for all sizes. Standard with 1/2" conduit housing and 18" wire leads. Various U.L. and NEMA approvals.

SINGLE SIDE PORTED SUBBASE



Available for all sizes. Two port size choices for sizes 1 through 3.

BRAD HARRISON® TYPE CONNECTOR



Available for all sizes in 3, 4 or 5 pin in single solenoid, and 4 or 5 pin in double solenoid.

Accessories

Ceram™ valve accessories customized for your application. Everything pipes directly into the base. That makes it easy to add accessories like flow controls or a regulator, or even a maintenance plate that allows a valve to be serviced while the other valves on the manifold operate.

SANDWICH FLOW CONTROL



Available for all sizes. Adjust via screw on each side.

SANDWICH REGULATOR



Available for sizes 1 through 3. Knob can lock in a given position.

DUAL PRESSURE SANDWICH REGULATOR



Available for sizes 1 through 3. Provides two separate delivery pressures.

MAINTENANCE PLATE



Available for sizes 1 through 3. Allows servicing of an individual valve in a manifold system

MATING SOLENOID CONNECTORS



Full line of 1/2" conduit and strain relief connectors for all valve sizes. Lighted and non-lighted versions



Focused
Delivery
Program

Some of the most popular Ceram™ valves are included in the AVENTICS Quick Ship Program:
www.aventics.com/us/QuickShipCeram



Specified by industries that demand tough valves due to their harsh operating environment. Ceram™ valves are very prevalent where ordinary valves just don't last. Industries such as: tire plants, foundries, paper mills, steel plants, concrete batch plants, sawmills, plywood and board plants, automotive assembly, rubber and plastics glass manufacturers, smelting, sheet metal fabrication, etc.



Concrete batching plant application. Ceram valves withstand harsh conditions and dirty air without "sticking".

Valve Sizes/Specifications

Valve Size	Ports NPT, ISO G (BSPP)	C _v	S.C.F.M.*
Size 1	1/4", 3/8"	1.1	40 SCFM
Size 2	3/8", 1/2"	2.4	86 SCFM
Size 3	1/2", 3/4"	4.3	155 SCFM
Size 4	1"	7.5	269 SCFM

*Flow measured with 87 psi (6 bar) supply pressure and 14.5 psi (1 bar) pressure drop across the valve.

■ Eliminate downtime—they don't stick

Normal air valves can stick or jam and cause start-up problems because of their inability to handle accumulations of dirt, dust, oil or water in air lines. Not with the Ceram valve. There's no gap between the plates for dirt and oil to accumulate. The plates are finished so precise that they act like sliding magnets or jo blocks. Solenoid operators of the same voltage on standard valves are interchangeable between all sizes, reducing spare parts inventory and downtime.

■ They work great in normal applications too

Just because they are so popular in harsh environments, don't think they won't work great in a more normal application.

■ Ceram valves save air and money

The tight shut-off with Ceram valves eliminates costly loss of air that is common in other designs. Compressed air that you pay for.

■ Overcomes design limitations of other valves

Lapped spool valves normally have a small gap between spool and sleeve that is prone to oil and dirt accumulation, resulting in sticking and the waste of air. Packed spool valves using elastomer seals are subject to deterioration and excessive wear when contamination and/or incompatible lubricants are present.

AVENTICS Corporation

1953 Mercer Road
Lexington, KY 40511
Tel 859.254.8031
Fax 800.489.1488
www.aventics.com/us
info.us@aventics.com



AVENTICS Incorporated

5515 North Service Rd
Suite #104
Burlington, Ontario L7L 6G4
Tel 905.332.0399
Fax 905.332.8596
www.aventics.com/ca
info.ca@aventics.com

Further contacts:

www.aventics.com/en/contact

The data specified only serve to describe the product. No statements concerning a certain condition or suitability for a certain application can be derived from our information. The information given does not release the user from the obligation of own judgment and verification. It must be remembered that our products are subject to a natural process of wear and aging.