

ITEM NO.	QTY. REQD	DWG. NO. PART NO.	DESCRIPTION
1	1	881-24	Parker LOW PRESSURE Hydraulic Hose - ϕ 1 1/2" I.D.
2	1	11743-24-24	Parker SAE Flange Head - 45° Elbow 1 1/2" X 1 1/2"
3	1	11943-24-24	Parker SAE Flange Head - 90° Elbow 1 1/2" X 1 1/2"

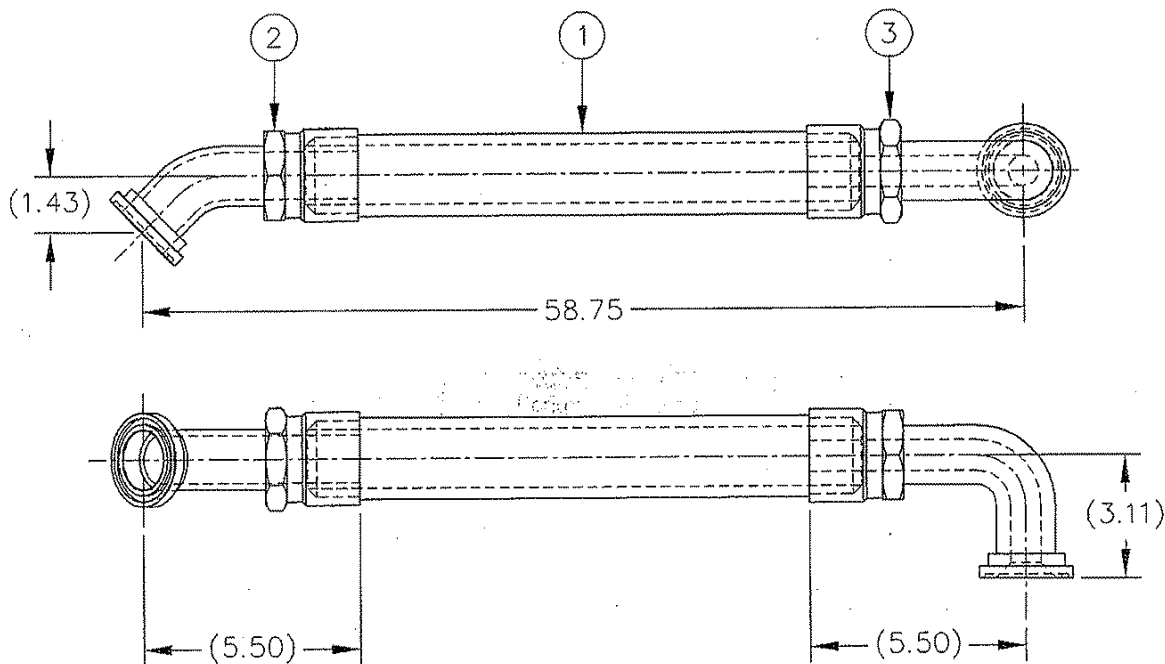

HOSE ASS'Y NO.: F881**1719242424-58.75"

MANUFACTURER: PARKER FLUID CONNECTORS

WORKING PRESSURE: 150 PSI

BURST PRESSURE: 600 PSI

NO.	REVISIONS	BY	DATE	CK.
MATL	FIN. WT.	 Metso Minerals Industries, Inc. 240 Arch St., P.O. Box 15312 York, PA 17405-7312 USA		
<small>This document and all information and design thereon are the property of Metso Industries, Inc., York, PA. This document is confidential and must not be made public or copied without prior written authorization from Metso and is subject to return upon demand. No use of this document or any information or designs thereon is permitted except as is specifically authorized in writing by Metso. Acceptance of possession of this document constitutes full agreement with the above conditions. Copyright © Metso Industries, Inc., 2002.</small>				
-PERMISSIBLE TOLERANCES FOR NON-LIMITED DIMENSIONS- -ALL TOLERANCES ARE NON-CUMULATIVE-				
FABRICATION AND CASTING DIMENSIONS		MACHINING DIMENSIONS		
ALL DIMENSIONS IN INCHES .X = ± 0.25" .XX = ± 0.12" .XXX = ± 0.062" ANGULAR = ± 2 DEGREES CHAMFER = ± 4 DEGREES		ALL DIMENSIONS IN INCHES .X = ± 0.06" .XX = ± 0.03" .XXX = ± 0.015" ANGULAR = ± 0°-15' MACHINE SURFACE FINISH 250 RMS - UNLESS NOTED		
HOSE ASSEMBLY ϕ1 1/2" I.D. HOSE X 58.75" LG PARKER				
DR.	CWR	DT.	01/17/2008	A 04-141908
CK.	ECB	DT.	01/17/2008	
APP.		SC.	NTS	