

Selection criteria for enclosures

The following questions will help you to select the most appropriate enclosure for your type of application from the wide range of the BERNSTEIN product line:

1. What are the dimensions of the required enclosure?

E.g. dimensions of printed circuit board, number of terminals, mechanical machining for cable glands, etc.
> [select the required external dimensions](#)

2. What is the operating environment?

E.g. moisture, climate, temperature, high-frequency radiation, etc.
> [select enclosure material, surface composition, gasket material](#)

3. What mechanical stress will occur?

E.g. impact stress, pressure, bending, etc.
> [select enclosure material](#)

4. What chemical resistance is required?

E.g. cleaning agents, oils, lubricants, etc.
> [select enclosure material](#)

5. What mechanical machining is necessary?

E.g. plugs, cable glands, windows, etc.
> [draw up a model sketch for mechanical machining](#)

6. Which accessories are required?

E.g. mounting plate, mounting rail, terminals, windows, external hinges, internal hinges, etc.
> [select required accessories](#)

7. Are any special made-to-order items necessary?

E.g. specific company colours, screen-printings of logos or symbols, etc.
> [select and determine colour, screen-printing, etc.](#)

Customised service

What does the BERNSTEIN customised service include?

This service can save you the inconvenience of machining and enables you to use the enclosure - as delivered by BERNSTEIN - directly in the production process.

- Mechanical machining, even intricate outlines, using modern CNC machining centres
- Special coatings in accordance with customer specifications
- HF-proof designs, given special coatings and conductive gaskets
- Screen-printings and engravings on the enclosure surface
- Mounting of individual components from the wide range of BERNSTEIN accessories (external and internal hinges, mounting plates, mounting rails, terminals, cable glands)
- If required, BERNSTEIN aluminium enclosures can be further protected by applying the environmentally-friendly C 6100 Alodine yellow-passivating method, for use in corrosive surroundings. The application of an additional primer and final coat further guarantee resistance to corrosion.

The BERNSTEIN quick release screw

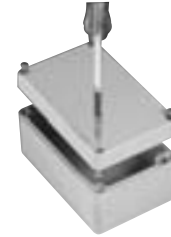

Invented and patented by BERNSTEIN, the quick release capability offers a useful innovation to our customers. The quick release screws save time and money if the enclosure is frequently opened and closed and comes with the following features:

1. Released through just a 90° turning action – closing and opening the enclosure with the quick release screws is considerably faster than with any other standard locking system (e.g. lid screws). This saves time and therefore money. All other mechanical characteristics of the enclosure and the IP 65 protection class are unaffected.
2. Easy lock/release at a glance the user can check whether the quick release is open or closed. This check does not involve any mechanical testing.
3. No accidental opening caused by vibration or shock. The quick release locks into place and is held there by a spring action. Accidental opening is impossible, thus increasing safety
4. Easy mounting – for any machining, coating or labelling that may be required by the customer at a later date, the quick release can be easily removed and then re-fitted. The screws are self-retaining in the lid.

BERNSTEIN quick-release internal hinge.

Simple, convenient, cost effective in addition to the quick release screws, BERNSTEIN offers the practical quick-release internal hinge for mounting enclosure lids on bases.

The alternative flexible internal hinges can be easily mounted on the enclosure without mechanical machining and can hold the enclosure lid after opening. In this way, the enclosure lid is both strain-relieved and captive.

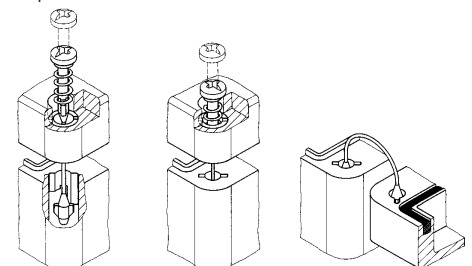

Protection class specification

In accordance with IEC 529, EN 60529, VDE 470 P 1

The protection class of a closed device indicates the level of protection from external factors. It includes the degree of protection afforded to personnel (from touching live parts) and protection of the device from the ingress of particles and water. BERNSTEIN standard enclosures generally conform to the protection class IP 65.

1 st number	Meaning
Code	Degree of protection from shock and against particles
0	non-protected
1	protected against solid particles < 50 mm Ø
2	protected against medium-sized particles < 12 mm Ø
3	protected against small particles < 2.5 mm Ø
4	protected against small particles < 2.5 mm Ø
5	protected against dust ingress
6	dust-proof and complete protection from accidental contact
2 nd number	Meaning
Code	Degree of protection against water
0	non-protected
1	protected against vertically dripping water
2	protected against dripping water, when tilted up to 15 degree
3	protected against spraying water
4	protected against splashing water
5	protected against water jets
6	protected against heavy seas or powerful jets of water
7	protected against water immersion
8	protected against submersion
BERNSTEIN-Enclosure standard IP 65	
BERNSTEIN-Enclosure in IP 66, IP 67 on request	

Protection class specification

In accordance with IEC 529, the specification of the protection class consists of a two-digit number.

Meaning of the 1st number:

Protection from accidental contact and ingress of foreign particles

Meaning of the 2nd number:

Protection against water ingress

Example: Protection class IP 65

1st number (6):
complete protection from accidental contact with live elements or from moving parts = protection from dust ingress

2nd number (5):
a jet of water from any direction will not damage the enclosure = protection against water jets

Mechanical stability

Mechanical stability is a major factor in determining the appropriate material. The following table specifies the essential properties of aluminium, polycarbonate, ABS and polyester.

Material property	Standard	Unit	Aluminium	Polycarbonate	ABS	Polyester
Density	DIN 53 479	g/cm ³	2.65	1.2	1.05	1.8
Impact strength	DIN 53 453	mJ/mm ²	150–300	65	60	80
Impact value	DIN 53 453	mJ/mm ²	90–200	20	10	4
Tensile strength	DIN 53 455	N/mm ²	180–300	65	43	45
Elongation at tear	DIN 53 455	%	60–90	90	20	20
Young's modules (bending test)	DIN 53 457	N/mm ²	75 000	2300	2100	6500
Limiting bending stress	DIN 53 452	N/mm ²		95	90	100
Burning behaviour	UL 94	Class		V 2	HB	V 0
Spec. contact resistance	DIN 53 482	Ω x cm		10 ¹⁵	10 ¹³	3 x 10 ¹⁴
Surface resistance	DIN 53 482	Ω		≥ 10 ¹⁵	4 x 10 ¹⁴	> 10 ¹²
Dielectric strength	DIN 53 481	kV/mm		25–40	24	25–40
Thermal conductivity (20 °C)	DIN 52 612	W/mK	120–160	0.21	0.18	0.25
Electr. conduct. capacity (20 °C)		m/Ω mm ²	15–22			

This diagram shows how different enclosure materials react under mechanical stress and in a harsh operating environment.

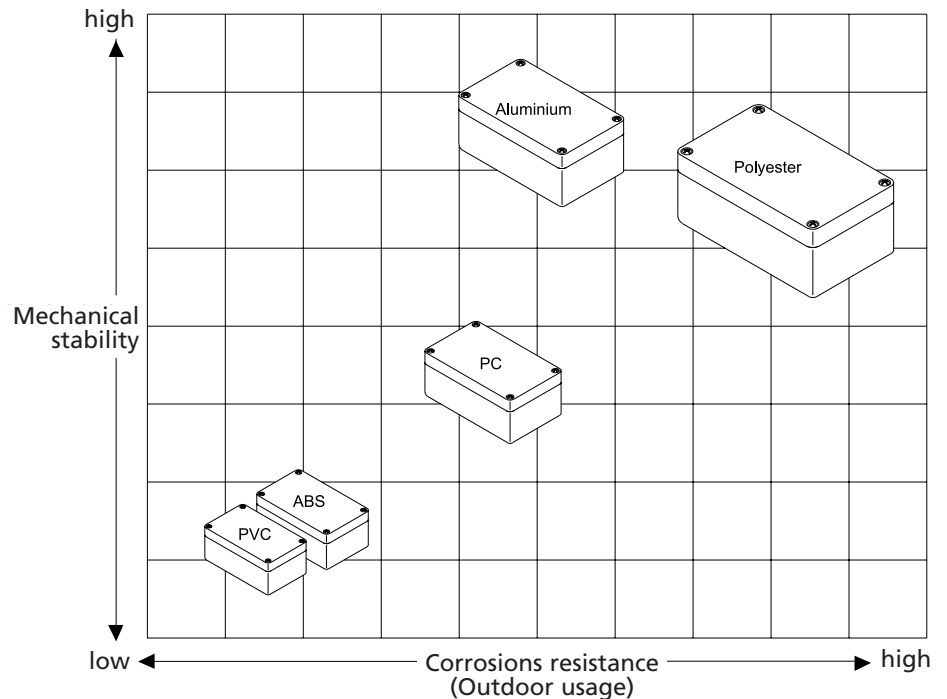

Chemical resistance

The degree of resistance to specific chemical substances depends on the material used for the enclosure. The following table specifies the resistance of BERNSTEIN aluminium, polycarbonate, ABS and polyester enclosures to certain chemicals frequently used in industrial surroundings. Please note that the table only gives standard values, since materials react differently to variations in chemical concentration or ambient temperatures. Furthermore, materials may react differently when exposed to several chemicals simultaneously. Appropriate preliminary tests are therefore recommended.

Our customers also have access to our in-house information service.

Chemicals	ABS	Polycarbonate	Polyester	Aluminium
Acetic acid	10% ○	10%	40%	+
Acetone	-	-	-	+
Acid	□	○	+	+
Ammonia	-	-	-	+
Benzene	-	-	+	+
Brake fluid	□	-	+	+
Butane	□	□	+	
Butanol	□	□	+	+
Calcium chloride	□	+	+	+
Carbon disulphide	□	-	-	+
Carbon tetrachloride	-	□	+	+
Caustic soda	-	-	40%	°
Chlorobenzene	-	-	+	+
Citric acid	10%	10%	+	+
Detergent	□	+	□	+
Diesel oil	+	○	+	+
Engine oils	□	+	+	+
Formaldehyde	+	□	30%	+
Formic acid	-	30%	10%	°
Freon 113	□	+	+	+
Fruit juice	□	+	+	+
Fuel oil	○	○	+	-
Glycerine	+	○	+	○
Hydraulic oil	□	+	+	+
Hydrochloric acid	10% ○	20%	+	+
Lactic acid	+	10%	+	+
Linseed oil	□	+	+	○
Lubricating oil	□	+	+	+
Methanol	□	-	-	○
Methylene chloride	□	-	-	+
Mineral oil	+	+	+	+
Nitric acid	30%	10%	10%	+
Oil of turpentine	□	□	+	○
Petrol	-	○	+	+
Potash lye	□	-	-	+
Potassium chloride	□	+	+	+
Potassium hydroxide	+	□	-	+
Soda ash	ó	+	+	+
Sodium chloride	ó	+	+	+
Sodium hydrate	+	□	-	+
Sulphuric acid	30%	50%	70%	+
Tartaric	□	10%	+	
Toluol	-	-	+	+
Trichloroethylene	-	□	-	+
Water (dist. water, river, tap, sea water)	+	+	+	+
Xylene	-	-	+	+
Zinc sulphate	□	+	+	○

The tests were performed at room temperature, if no other value is specified. If different substances are mixed, resistance may alter. No responsibility can therefore be accepted for the accuracy of specifications.

- +: resistant to all concentrations
- %: resistant to max. % concentrations
- : limited resistance
- : non-resistant
- : not known

Customised service

Advantages

The extensive BERNSTEIN customising service for standard enclosures offers some distinct advantages:

- The custom-made enclosure can be used immediately in the production process.
- Reducing production time and range, transferring risk to the supplier.
- Saving time by minimised handling and reduced logistics expenditure.
- Economical machining by BERNSTEIN specialists, using up-to-date equipment and thereby lowering costs.
- The customer benefits from BERNSTEIN's wealth of experience in providing a customised service.

What does the BERNSTEIN customised service include?

This service can save you the inconvenience of machining and enables you to use the enclosure – as delivered by BERNSTEIN – directly in the production process.

- Mechanical machining, even intricate outlines, using modern CNC machining centres
- Special coatings in accordance with customer specifications
- HF-proof designs, given special coatings and conductive gaskets
- Screen-printings and engravings on the enclosure surface
- Mounting of individual components from the wide range of BERNSTEIN accessories (external and internal hinges, mounting plates, mounting rails, terminals, cable glands)

The BERNSTEIN comprehensive customising service meets all requirements

Drilling

We can drill holes in all enclosure materials to meet your own specifications.

Threading

We can cut metric screw threads from M 12 x 1.5 to M 63 x 1.5. We can, if required, also provide special thread types (PG threads, imperial threads and NPT threads).

Milling

The experts in our CNC machining centres can also undertake complicated milling on your behalf. All machining procedures are archived for each individual customer so that they then can be repeated whenever necessary. This ensures that a consistently high standard is maintained.

Passivating

If required, BERNSTEIN aluminium enclosures can be further protected by applying the environmentally-friendly C 6100 Alodine yellow-passivating method, for use in corrosive surroundings. The application of an additional primer and final coat further guarantee resistance to corrosion.

Coating

We can supply enclosures in any colour or shade both RAL and non-standard colours. Standard and special colours are applied as wet or powder coating.

Screen-printing

We can print your enclosure surfaces and front plates in single-colour or multi-colour, as required, using durable colours suitable for industrial usage.

Engraving

Our computer-controlled engraving machines engrave all types of fonts and outlines.

Assembly

Components are, of course, assembled to meet your own individual requirements. Just select the mounting plates, mounting rails, terminal blocks, cable glands etc. from the wide range of BERNSTEIN accessories.

BERNSTEIN manufacturing standard

Technical information for enclosure machining

As an ISO 9001 certified company, BERNSTEIN has defined a manufacturing standard that is applied to all machining orders without alternative customer specification.

Dimension tolerances

When preparing details for enclosure machining (see following drawings, showing orientation of enclosure when set up for machining), tolerances used for the first machining operation on each set up, are according to ISO 2768-mH.

If other dimensions or reference edges are used, the following maximum general tolerances are applicable for the first machining operation on each enclosure per set up (see table below).

Tolerances between further machining operations compared to each other can be limited to ± 0.1 mm.

General tolerances Standard programme

Die-casting (dc)	DIN 1688
CA-020 to CA-310	Part 4 GTA 13/5
CA-350, CA-370,	(August 1986)
CA-380, CA-400,	
CA-450	
Chilled casting (cc)	DIN 1688
CA-330, CA-360	Part 3 GTA 14/5
CA-390, CA-420,	(October 1980)
CA-460, CA-470,	
CA-480	
Resin-impregnated polyester moulding compounds	DIN 16901-130 (November 1982)
CP-140 to CP-280	
Resin-impregnated polyester mats	DIN 16901-140 (November 1982)
CP-300 to CPS-590	
PC/ABS	DIN 16901-130
CT-50 to CT-91	(November 1982)
Sand casting (G)	DIN 1688
	Part 1 GTA 15/5
	(October 1980)

Reference edges for BERNSTEIN machining standards

Series

CA-020 to CA-240, CA-270 to CA-300
CT-50 to CT-82, CP-140 to CP-300

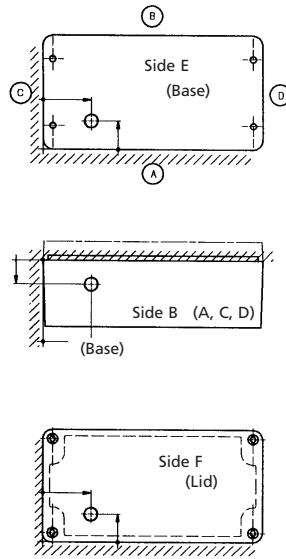

Series

CA-250, CA-310 to CA-480
CT-84 to CT-91, CP-320 to CPS-590

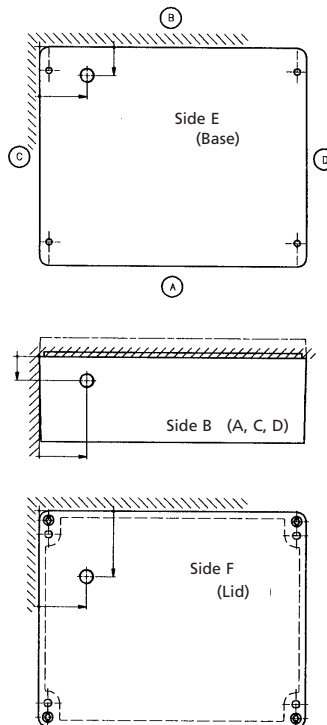

Minimum quantities

In order to keep enclosure machining as cost-effective for the user as possible, the following minimum purchase quantities are suggested:

Name	Minimum
CA-020 ... CA-080	20 pieces
CA-100 ... CA-190	10 pieces
CA-210 ... CA-310	10 pieces
CA-330 ... CA-480	5 pieces
CC-280 ... CC-480	5 pieces
CP-140 ... CP-195	20 pieces
CP-220 ... CP-320	10 pieces
CP-330 ... CP-460	5 pieces
CT-50 ... CT-76	20 pieces
CT-78 ... CT-89	10 pieces

These quantities should be regarded as the minimum, if the customised enclosures are to be produced economically. Production includes mechanical machining, special coating, screen-printing, engraving or assembly of accessories. BERNSTEIN distributors will of course be pleased to advise you.