

*Industrial-PC*

# CPS21T Control Panel Connectivity Manual

Edition

# 101



**BOSCH**  
Automation

*Industrial-PC*

# **CPS21T Control Panel Connectivity Manual**

1070 073 826-101 (01.10) GB



© 2001

by Robert Bosch GmbH, Erbach / Germany  
All rights reserved, including applications for protective rights.  
Reproduction or distribution by any means subject to our prior written permission.

Discretionary charge 6.– €

# Contents

	Page
<b>1</b>	<b>Safety Instructions</b> . . . . . <b>1-1</b>
1.1	Intended use . . . . . 1-1
1.2	Qualified personnel . . . . . 1-2
1.3	Safety markings on products . . . . . 1-3
1.4	Safety instructions in this manual . . . . . 1-4
1.5	Safety instructions for the described product . . . . . 1-5
1.6	Documentation, software release and trademarks . . . . . 1-7
<b>2</b>	<b>System overview control panels</b> . . . . . <b>2-1</b>
2.1	Variations . . . . . 2-2
2.2	Components . . . . . 2-3
2.3	Operating conditions . . . . . 2-3
2.4	Standards compatibility . . . . . 2-4
<b>3</b>	<b>Display and operating elements</b> . . . . . <b>3-1</b>
3.1	TFT flat screen display . . . . . 3-1
3.2	Touch screen controller . . . . . 3-2
3.3	Backlight timer function . . . . . 3-3
3.4	Navigation keys (only CPS21T with keypad) . . . . . 3-4
3.5	Keypad (only CPS21T with keypad) . . . . . 3-4
3.6	Keyboard controller . . . . . 3-5
3.6.1	Scanning the front panel keys . . . . . 3-5
3.6.2	User-defined assignment of the key codes . . . . . 3-7
3.6.3	Software download for the keyboard controller . . . . . 3-7
<b>4</b>	<b>Installation</b> . . . . . <b>4-1</b>
4.1	Installed positions and clearances . . . . . 4-2
4.2	Dimensioned drawings . . . . . 4-3
4.3	Mounting CPS21T with swivel/incline adapter . . . . . 4-5
<b>5</b>	<b>Electrical connection</b> . . . . . <b>5-1</b>
5.1	24 VDC power supply . . . . . 5-1
5.2	Control devices . . . . . 5-4
<b>6</b>	<b>Interfaces</b> . . . . . <b>6-1</b>
6.1	Overview of ports and connectors . . . . . 6-1
6.2	Port and connector layout . . . . . 6-2
6.3	Supply and distribution circuit board (only CPS21T with keypad) . . . . . 6-4
6.4	LVDS video signal interface . . . . . 6-7
6.5	Keyboard connector . . . . . 6-8
6.6	Mouse port . . . . . 6-11
6.7	X33 power supply input . . . . . 6-12
6.8	24 VOut-interface . . . . . 6-13
<b>7</b>	<b>Maintenance and replacement</b> . . . . . <b>7-1</b>
7.1	Maintenance schedule . . . . . 7-1
7.2	Replacing the backlight and display . . . . . 7-2

<b>8</b>	<b>Ordering Numbers</b> .....	<b>8-1</b>
8.1	Control panels .....	8-1
8.2	Accessories .....	8-1
<b>A</b>	<b>Appendix</b> .....	<b>A-1</b>
A.1	Index .....	A-1

# 1 Safety Instructions

Before you start working with the CPS21T control panel, we recommend that you thoroughly familiarize yourself with the contents of this manual. Keep this manual in a place where it is always accessible to all users.

## 1.1 Intended use

This manual contains information required for the proper use of this product. However, for reasons of structural clarity, the manual cannot provide exhaustive details regarding all available combinations of functional options. Similarly, it is feasible to consider every conceivable integration or operating scenario within the confines of this manual.

The described control panel serves as a **visualization unit** for application software and as a **terminal unit** for Bosch Industrial PC (IPC) and controller rho4.

The products described hereunder

- have been developed, manufactured, tested and documented in compliance with the safety standards. These products pose no danger to persons or property if they are used in accordance with the handling stipulations and safety notes prescribed for their configuration, mounting, and proper operation.
  - comply with the requirements of
    - the EMC Directives (89/336/EEC, 93/68/EEC and 93/44/EEC)
    - the Low-Voltage Directive (73/23/EEC)
    - the harmonized standards EN 50081-2 and EN 50082-2
  - are designed for operation in industrial environments, i.e.
    - no direct connection to public low-voltage power supply,
    - connection to the medium- or high-voltage system via a transformer.
- In residential environments, in trade and commerce as well as small enterprises class A equipment may only be used if it does not inadmissibly interfere with other equipment.

 **This is a Class A device. In a residential area, this device may cause radio interference. In such case, the user may be required to introduce suitable countermeasures, and to bear the cost of the same.**

The faultless, safe functioning of the product requires proper transport, storage, erection and installation as well as careful operation.

## 1.2 Qualified personnel

The requirements as to qualified personnel depend on the qualification profiles described by ZVEI (Zentralverband Elektrotechnik und Elektronikindustrie – German Electrical and Electronic Manufacturers' Association) and the VDMA (Verband deutscher Maschinen- und Anlagenbau – German Engineering Federation) in:

**Weiterbildung in der Automatisierungstechnik**  
**edited by: ZVEI and VDMA**  
**MaschinenbauVerlag**  
**Postfach 71 08 64**  
**60498 Frankfurt/Germany**

The present manual is designed for project engineers and PC specialists. They need special knowledge on configuration and commissioning of electrical equipment.

Interventions in the hardware and software of our products, unless described otherwise in this manual, are reserved to our specialized personnel.

Tampering with the hardware or software, ignoring warning signs attached to the components, or non-compliance with the warning notes given in this manual may result in serious bodily injury or material damage.

Only electrotechnicians as recognized under IEV 826-09-01 (modified) who are familiar with the contents of this manual may install and service the products described.

Such personnel are

- those who, being well trained and experienced in their field and familiar with the relevant norms, are able to analyze the jobs being carried out and recognize any hazards which may have arisen.
- those who have acquired the same amount of expert knowledge through years of experience that would normally be acquired through formal technical training.

With regard to the foregoing, please note our comprehensive range of training courses. Our training center will be pleased to provide you with further information,  
telephone: (+49) (0 60 62) 78-258.

### 1.3 Safety markings on products



Warning of dangerous electrical voltage!



Electrostatically sensitive components!



Lug for connecting PE conductor only!



Connection of shield conductor only



Disconnect mains power before opening!

## 1.4 Safety instructions in this manual

---



### **DANGEROUS ELECTRICAL VOLTAGE**

This symbol is used to warn of a **dangerous electrical voltage**. The failure to observe the instructions in this manual in whole or in part may result in **personal injury**.

---



### **DANGER**

This symbol is used wherever insufficient or lacking compliance with instructions may result in **personal injury**.

---



### **CAUTION**

This symbol is used wherever insufficient or lacking compliance with instructions may result in **damage to equipment or data files**.

---

 This symbol is used to draw the user's attention to special circumstances.

★ This symbol is used if user activities are required.



## 1.5 Safety instructions for the described product

---

**DANGER**

Danger of life through inadequate EMERGENCY-STOP devices! EMERGENCY-STOP devices must be active and within reach in all system modes. Releasing an EMERGENCY-STOP device must not result in an uncontrolled restart of the system!

First check the EMERGENCY-STOP circuit, then switch the system on!

---

**DANGER**

Retrofits or modifications may adversely affect the safety of the products described!

The consequences may include severe injury, damage to equipment, or environmental hazards. Possible retrofits or modifications to the system using third-party equipment therefore have to be approved by Bosch.

---

**DANGEROUS ELECTRICAL VOLTAGE**

Unless described otherwise, maintenance works must be performed on inactive systems! The system must be protected against unauthorized or accidental reclosing.

Measuring or test activities on the live system are reserved to qualified electrical personnel!

---

**CAUTION**

Use only spare parts approved by Bosch!

---

**CAUTION**

Danger to the module!

All ESD protection measures must be observed when using the module! Prevent electrostatic discharges!

---

The following protective measures must be observed for modules and components sensitive to electrostatic discharge (ESD)!

- Personnel responsible for storage, transport, and handling must have training in ESD protection.
- ESD-sensitive components must be stored and transported in the prescribed protective packaging.
- ESD-sensitive components may only be handled at special ESD-workplaces.
- Personnel, working surfaces, as well as all equipment and tools which may come into contact with ESD-sensitive components must have the same potential (e.g. by grounding).
- Wear an approved grounding bracelet. The grounding bracelet must be connected with the working surface through a cable with an integrated 1 M $\Omega$  resistor.
- ESD-sensitive components may by no means come into contact with chargeable objects, including most plastic materials.
- When ESD-sensitive components are installed in or removed from equipment, the equipment must be de-energized.

## 1.6 Documentation, software release and trademarks

### Documentation

The present manual provides technical data and information about operation and configuration of the CPS21T control panel.

Overview of available documentation	Part no.	
	German	English
IPC, IPC300 Connectivity Manual	1070 073 812	1070 073 822
CPS21T Control Panel Connectivity Manual	1070 073 816	1070 073 826

Special keys or key combinations are shown enclosed in pointed brackets:

- Named keys: e.g., <Enter>, <PgUp>, <Del>
- Key combinations (pressed simultaneously): e.g., <Ctrl> + <PgUp>

### Trademarks

All trademarks of software installed on Bosch products upon delivery are the property of the respective manufacturer.

Upon delivery, all installed software is copyright-protected. The software may only be reproduced with the approval of Bosch or in accordance with the license agreement of the respective manufacturer.

MS-DOS® and Windows™ are registered trademarks of Microsoft Corporation.

PROFIBUS® is a registered trademark of the PROFIBUS Nutzerorganisation e.V. (user organization).

Notes:

## 2 System overview control panels

The control panel CPS21T is a complete mechanical unit consisting of a

- closed aluminum housing with
- Color LC Display,
- Membrane keys as well as additional operating elements (control devices)

The control panel CPS21T is designed for industrial use. They feature specially designed interfaces (e.g., fail safe transmission procedure for video, mouse and keyboard signals). connection

The robust and fail safe technology makes the CPS21T series Control Panels particularly suited the following uses:

- Visualization / display unit for control unit processes
- Input terminals for industrial control units

They are used in conjunction with the Bosch Industry PC "IPC 300".

 **The connection of the CPS21T to the PCs of other manufacturers is not possible.**

CPS21T with keypad (front view)



## 2.1 Variations

The control panels are available in a screen size with or without control devices:

- **CPS21T with keypad** with 15" touch screen flat display, keypad (3 control devices) and navigation keys
- **CPS21T without keypad** with 15" touch screen flat display without keypad as well as without navigation keys

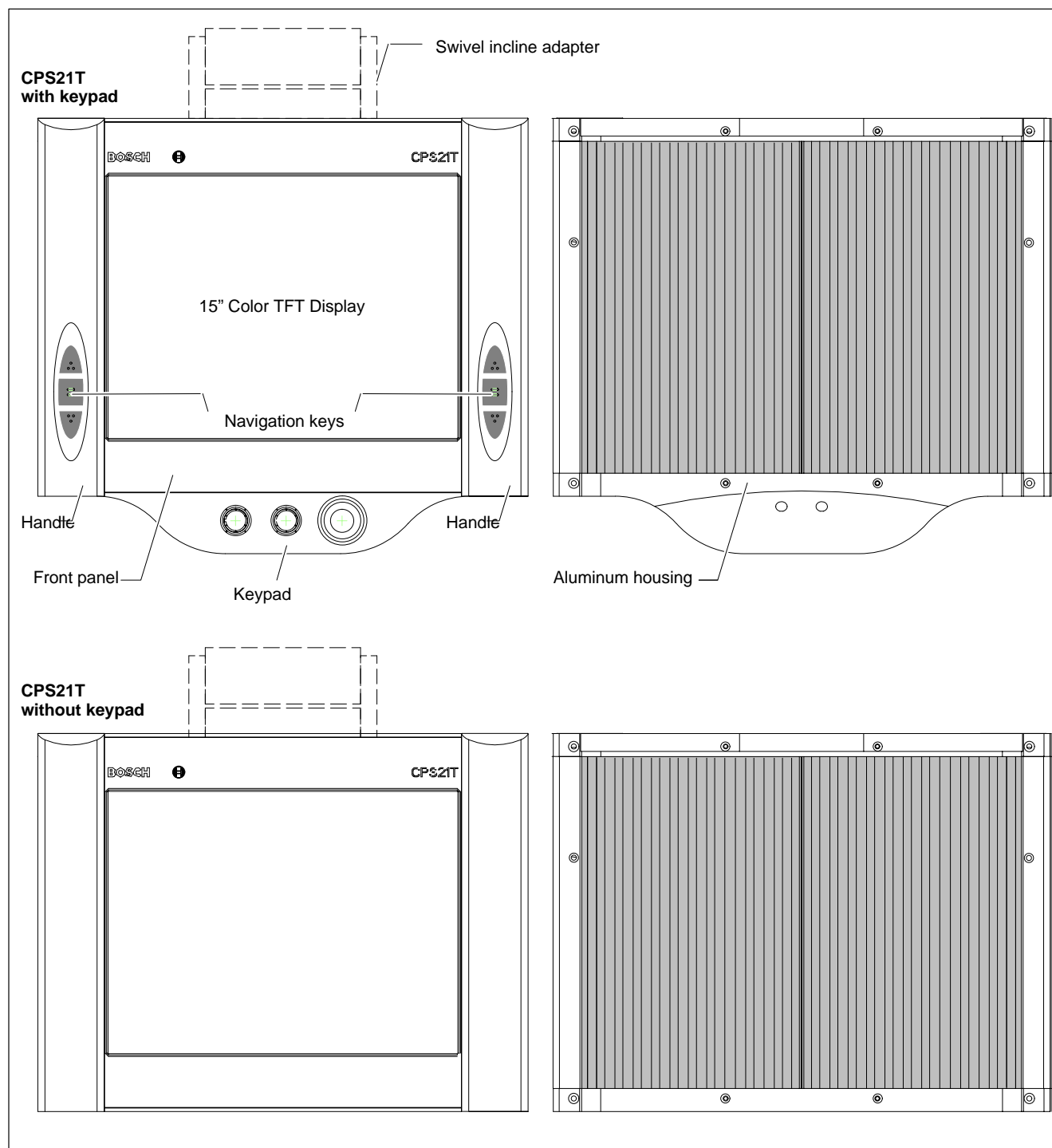

## 2.2 Components

<b>Housing:</b>	The anodized aluminum housing completely surrounds the control panel and is equipped with cooling gill inside and outside. This allows a passive cooling of the control panel under the specified operating conditions (refer to section 2.3). It is screwed to the front panel.
<b>Front panel:</b>	The display, 2x3 membrane keys (navigation keys) and the keypad with 3 control devices (CPS21T Version M) is fixed on the front panel. After removing the covers and loosening the screws, the display unit can be replaced (refer to section 7.2.)
<b>Handle:</b>	On both left and right side of the front panel a handle bar is fixed. For a user-friendly operation, there are cut-outs for every 3 navigation keys (CPS21T Version M).
<b>Suspension:</b>	The complete CPS21T unit is prepared for the gallows mounting (in this regard, refer to section 4.3).

## 2.3 Operating conditions

All control panels are designed for continuous operation (24 hours/day). The display backlight can be switched off (refer to page 3-3).

The following specifications apply unless otherwise indicated in the individual sections:

### Temperatures

#### Storage temperature

- CPS21T: -20°C to +50°C

#### Ambient temperature

(for installation conditions described in Section 4)

- CPS21T: +0°C to +45°C

Temperature fluctuations of up to 3°C per minute are permitted.



#### CAUTION

**Excessive operating temperature!**

**Do not expose the housing of the CPS21T to direct sunlight or other sources of heat radiation!**

---

### Relative humidity

Climate class 3K3, as per EN 60529; condensation not permitted.

### Air gap/creepage distance

as per prEN50178 (11/96) at pollution level 2

### Atmospheric pressure

To DIN 60204, when operating at altitudes up to 2000 m above sea level.

**Protection category**

- CPS21T: front cover IP65, otherwise IP54  
Sheet metal housing(inside) IP00

**Resistance**

Resistance to abrasion and resistance of all surfaces against mediums like:

- Solvent naphtha (CH20V3)
- n-Heptane
- Test oil (VS15665)
- Hydraulic oil
- Lubricants
- Water

**CAUTION****Conditions hazardous to the product!**

**The ambient air must be free of electrically conductive pollutants (e.g., acids, alkali, corrosives, salts, metallic vapours, etc.). Air intake and exhaust filters must be serviced at regular intervals.**

**Vibration resistance, operating**

Frequency range: 10 to 150 Hz  
Amplitude: 0.075 mm at 10 to 57 Hz  
Acceleration: 1 g at 57 to 150 Hz  
to EN 60068-2-6

**Impact resistance**

15 g as per DIN IEC 68-2-27, no functional impediment.  
Frequency range: 10...150 Hz  
Amplitude: 0.075 mm at 10 to 57 Hz  
Acceleration: 1 g at 57 to 150 Hz

**2.4 Standards compatibility**

The control panels are certified to comply with the following standards:

- EN 60,204-1 Electrical systems on machines
- EN 50,081-2 Basic specification for interference emission (industrial environment)
- EN 50 082-2 Basic technical standard, interference resistance (industrial environment)
- EN50178 with respect to VDE160
- EN 60,950 Overvoltage category II
- EN 418 Machine safety, Emergency STOP devices
- EN 60,529 Protection categories (incl. housings and installation compartments)
- EN 60 721 Classification of environmental conditions
- EN 60 068-2-6 Vibration test
- EN 60 068-2-27 Impact test
- .IS.114 "X ray Radiation" Dir., as per Official Fed. Gazette



**For all CPS21Ts shipped from the factory, the CE licensing requirements have been met.**



### 3 Display and operating elements

All flat screen displays feature touch screen functions.

They consist of the following components:

- Thin film transistor (TFT) display
- touch screen
- Backlight.

The display elements are located behind a splash-proof sealed film.

In addition, the following elements are located on the front panel

- Membrane keys (only CPS21T version M)
- Control devices for START, STOP and EMERGENCY-STOP (only CPS21T with keypad)
- Key controller.

#### 3.1 TFT flat screen display

Due to its shallow installation depth, the TFT (Thin Film Transistor) display is ideally suited to the subject control panel application. It features excellent contrast and wide angle viewability. The display colours are adapted to the requirements of the application environment by means of settings in the operating system, or via the respective application software.

#### CPS21T with Gigabit interface

The display of the control panel CPS21T is produced via 2 lines with the Bosch IPC300 via the Gigabit interface LCD and via the power supply connection X33 (refer to section 6).

The display resolution must be selected in the connected IPC300 via the S1 DIP switch (see diagram below):

- CPS21T (15" color display): 1024 x 768 Pixel

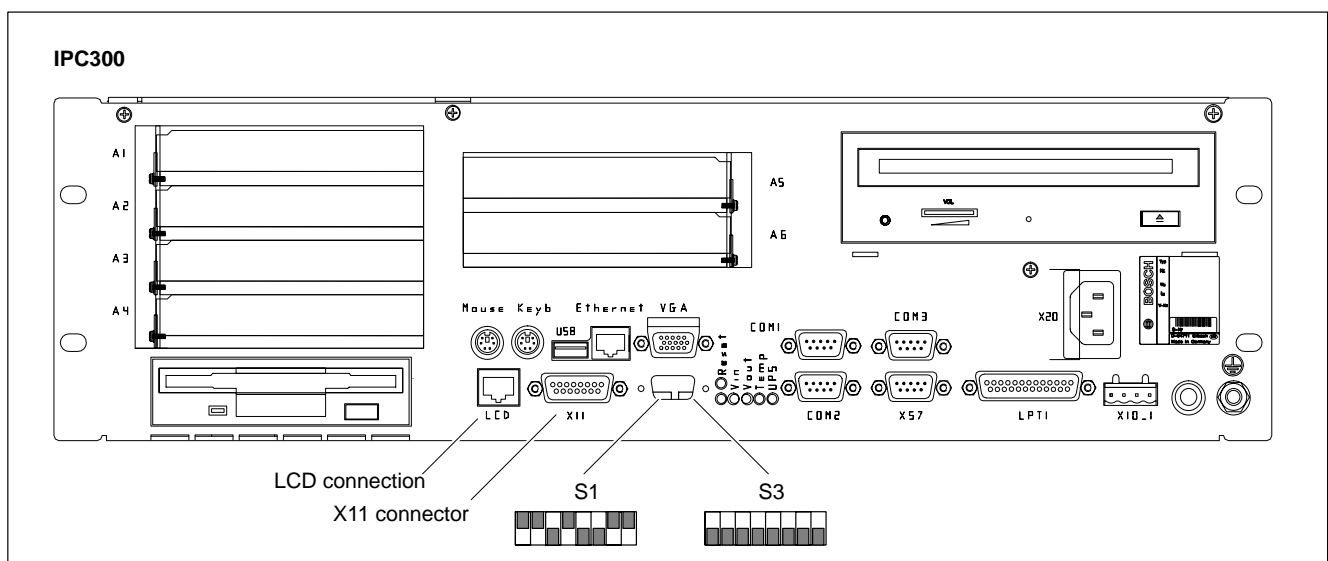

To change display resolutions, switches 1 through 8 on the externally accessible S1 DIP switch can be set as follows:

- 1024 x 768 pixels



## 3.2 Touch screen controller

All control panels are supplied with a touch screen controller. The touch screen facilitates manual operation via the touch sensitive display surface, and replaces the mouse. The calibration of the touch screen takes place with the help of software on the IPC300.

The touch screen controller functions are communicated via the dedicated COM2 port on the IPC300.

### Software drivers

Operation of the touch screen requires the appropriate software drivers for the operating system. To install the drivers, proceed as follows:

- from CONTROL PANEL ► MOUSE ► DISKETTE  
and select the touch screen controller on the path:

IPC300: C:\Rbtool\Elotouch\MMWin95\Setup.exe (Windows 95)  
OR:  
C:\Rbtool\Elotouch\MMWinNT\Setup.exe (Windows NT)

- or Version 3.10 onwards (only Windows NT) directly using the corresponding SETUP.EXE file:

C:\Rbtool\Elo-DRV\EloNT\Setup.exe

### 3.3 Backlight timer function

The fluorescent backlight tube provides the background lighting for the TFT display. After approx. 40,000 operating hours, the tube will produce only 50% of its original brightness since it has a limited service life. Refer to Section 7.2 for information about replacing the backlight unit.

To extend the service life of both display and backlight tube, the flat screen display features a timer ("sleep") function for the backlight. This circuit darkens the display if the control panel is not operated for a preset period of time.

#### Activating the backlight timer

The backlight timer is activated on the IPC 300:

- ★ In the BIOS setup, select the menu option:
  - **IPC300:**    POWER ► LCD Backlight Off Timer

Then set the timer to an interval between 28 seconds and 14 minutes.

- ★ To ensure that the screen contents no longer change, go to the operating system, and select a screen saver which will darken the display (Blank Screen, i.e., no objects on the screen).  
Select a wait time for the screen saver that is shorter than the interval time of the backlight timer.

Any keyboard input, mouse movement or contact with the touch screen will again activate the backlight, and the display will again appear.

### 3.4 Navigation keys (only CPS21T with keypad)

- 2 x 3 Navigation keys (membrane keys) vertically on the right and left side of the display in the handle bars.  
Designation: none



### 3.5 Keypad (only CPS21T with keypad)

The keypad is provided below the display and contains control devices:

- 1 x EMERGENCY-STOP (red, circumvention-safe as per EN 418)
- 1 x pushbutton STOP, black without lamp
- 1 x pushbutton START, white with lamp

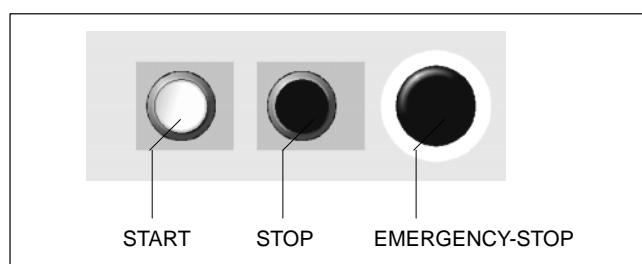

 **Information concerning the electrical characteristics of the control devices can be found in chapter 5.2.**

## 3.6 Keyboard controller

For many industrial applications it is important to determine the key status (pressed/not pressed, key LED ON/OFF) of the front panel keyboard. For this, a keyboard controller or an external keyboard scans the front panel keys and transfers the key codes, switch positions etc. to various interfaces.

### 3.6.1 Scanning the front panel keys

The current status of the front panel keys is passed on

- to the PC via MF2
- to the 24VOut output

The codes can be processed further by the application program via 24VOut.

#### Transferring the key codes (MF2) to the PC

The MF2 codes are available in the standard design in the first input byte and are passed on from the controller to the PC (refer to the assignment table on page 3-6).

#### Transferring the key codes to the 24 VOut-outputs

 **Bit 1 corresponds to the low-order bit.**

Pressed navigation keys are bit coded and immediately applied by the controller to the output 24 VOut.

- Bit1: **CRTL-L** (corresponds to S10)
- Bit2: **CRTL-R** (corresponds to S13)
- Bit3: **CRTL-U, CRTL-D** (corresponds to S09 or S11 or S12 or S14)

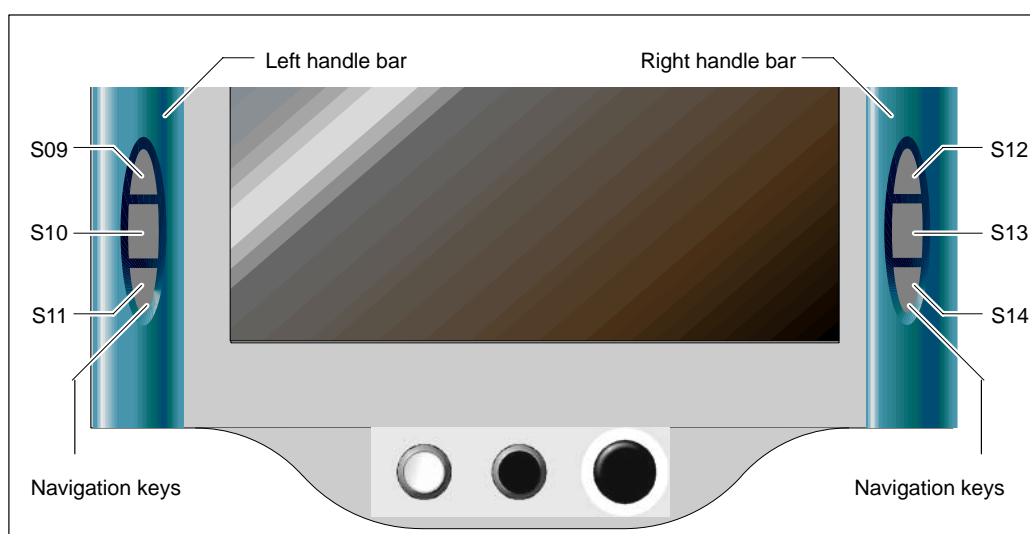

In this regard, also refer to the “code assignment table on page 3-6”.

## Keys, control devices, LED's (designations):

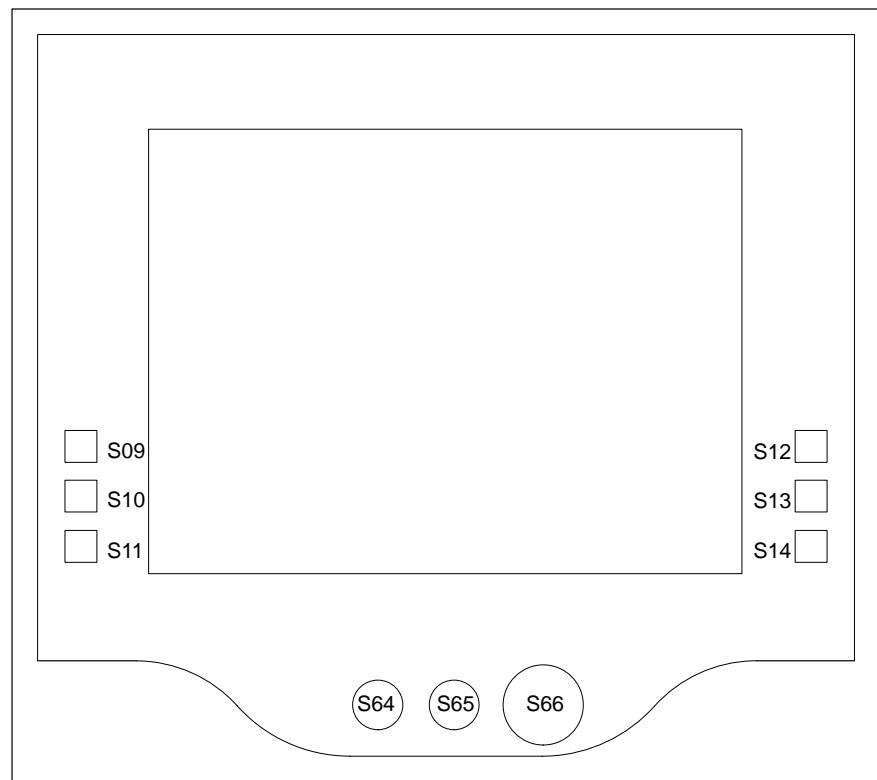

## Standard code assignment of the keys, control devices and LED's

Key no./ control de- vice	MF2	Mouse	Repeat	COM3	24 Vout	Type of key	LED
S09	CRTL-U	-	Yes	-	Bit3	ST2	-
S10	CRTL-L	-	Yes	-	Bit1	ST2	-
S11	CRTL-D	-	Yes	-	Bit3	ST2	-
S12	CRTL-U	-	Yes	-	Bit3	ST2	-
S13	CRTL-R	-	Yes	-	Bit2	ST2	-
S14	CRTL-D	-	Yes	-	Bit3	ST2	-
S64 (START)	-	-	-	-	-	Rafix 16	24 V glow
S65 (STOP)	-	-	-	-	-	Rafix 16	-
S66 (EMER- GENCY- STOP)	-	-	-	-	-	Rafix 16	-

 The control devices S64, S65, S66, S09 to S14 are included only in the CPS21T Version M.

### 3.6.2 User-defined assignment of the key codes

The keycodes can be changed dynamically.

The following key characteristics can be set as code:

- Explanation of keys (e.g. "CTRL-L", "CTRL-R",...)
- Position of the keys within the keyboard
- Outputting the key position and explanation to the 24 VOut outputs

You can receive further information in this regard on request.



#### DANGER

An incorrect assignment of the key codes can under certain circumstances lead to

- operating errors in the applications
- system crash
- failure of the system to start up

Carefully test the new key assignment for possible erroneous assignment of the keys.

### 3.6.3 Software download for the keyboard controller

New key codes for the keyboard controller are loaded via the integrated V24 interface of the X33 port.

For this, on the IPC300, the switches 1 and 2 of **S3** (position: refer to page 3-1) are to be closed (ON) in order to connect the COM 3 port to the keyboard controller (internally).



 Customer-specific key codes can be downloaded on request and after arrangement is made by Bosch Erbach.

Notes:



## 4 Installation

With respect to installation, observe the information about applicable standards and operating conditions in Sections 2.4 and 2.3.



### CAUTION

Conditions hazardous to the product! The ambient air must be free of electrically conductive pollutants (e.g., acids, alkali, corrosives, salts, metallic vapors, etc.).

---

### Note

- The use of silicon based sealing compounds, adhesives and insulating agents is prohibited.
- Ensure that the installation is maintenance friendly, i.e., that it provides unrestricted access to connections, cables and fuses.
- Precede all installation procedures by writing down the information on equipment rating plates. In the event that rating plates are hidden from view as a result of the installation, you will still have quick access to this information whenever required.

## 4.1 Installed positions and clearances

Housing:	Front panel: aluminum housing:	Protection category IP 65 Protection category IP 54
Weight:	approx. 8 kg	
Installed position:	vertical, 0° up to max. ±45° inclined position	
Installation type:	for gallows mounting, sealed as per IP54	

 **Remember that the front of the control panel may become dirty more quickly if installed at an angle, instead of being installed vertically.**



### CAUTION

**Excessive operating temperature!**

**Do not expose the housing of the CPS21T to direct sunlight or other sources of heat radiation!**

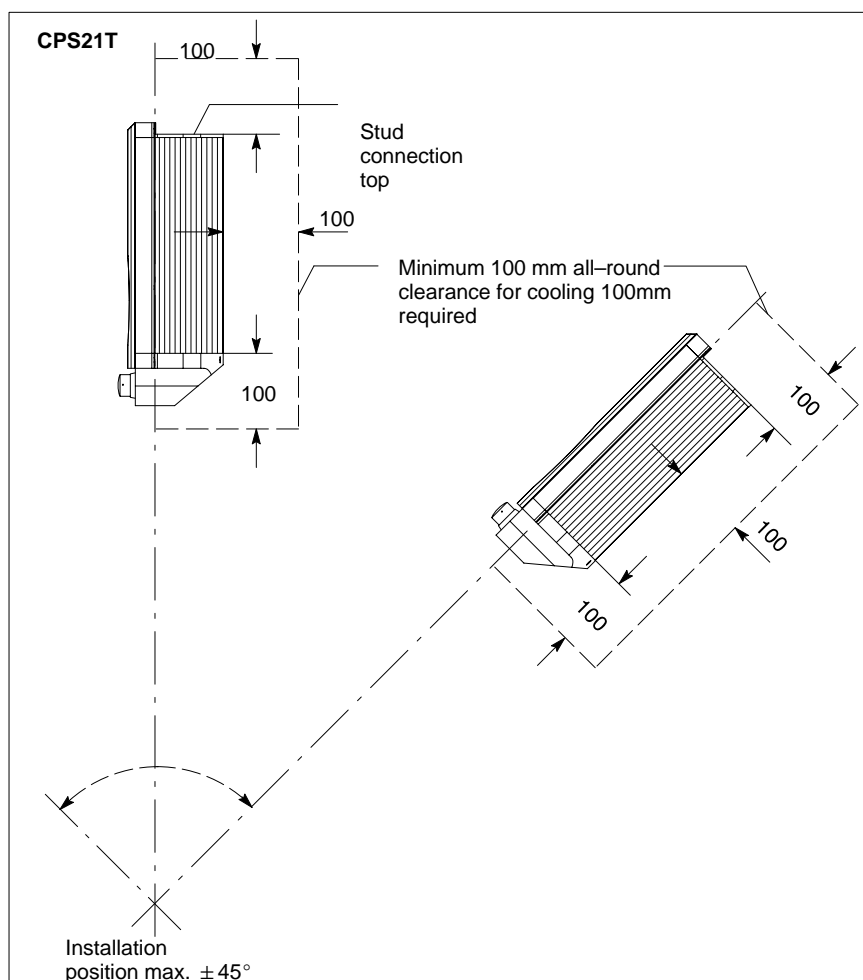

- Install the control panel, ensuring that it can be operated ergonomically. In addition, the operator must be provided with a permanent and unobstructed line of sight on moving machine components!

- To prevent reduced screen readability and additional thermal load, avoid installation locations that are exposed to direct sunlight.
- To provide sufficient ventilation and cable routing space, provide an all round minimum clearance of 50 mm.
- Allow for connecting loops in all cable routings; provide strain relief for all cables.
- Maintain suitably large distances from sources of interference.
- Use only silicon free sealing compounds, adhesives and insulating agents.

## 4.2 Dimensioned drawings

### CPS21T with keypad

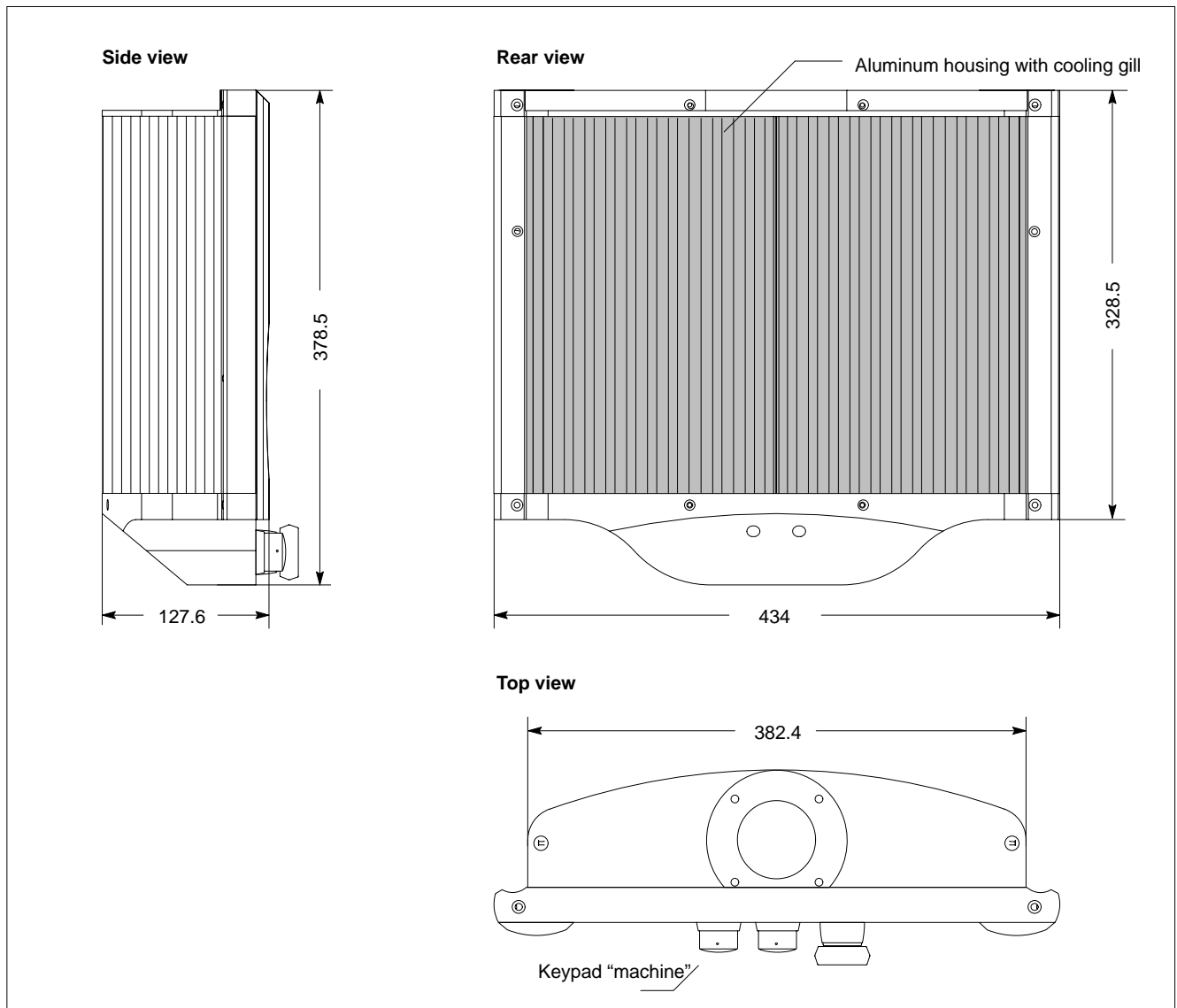

## CPS21T without keypad

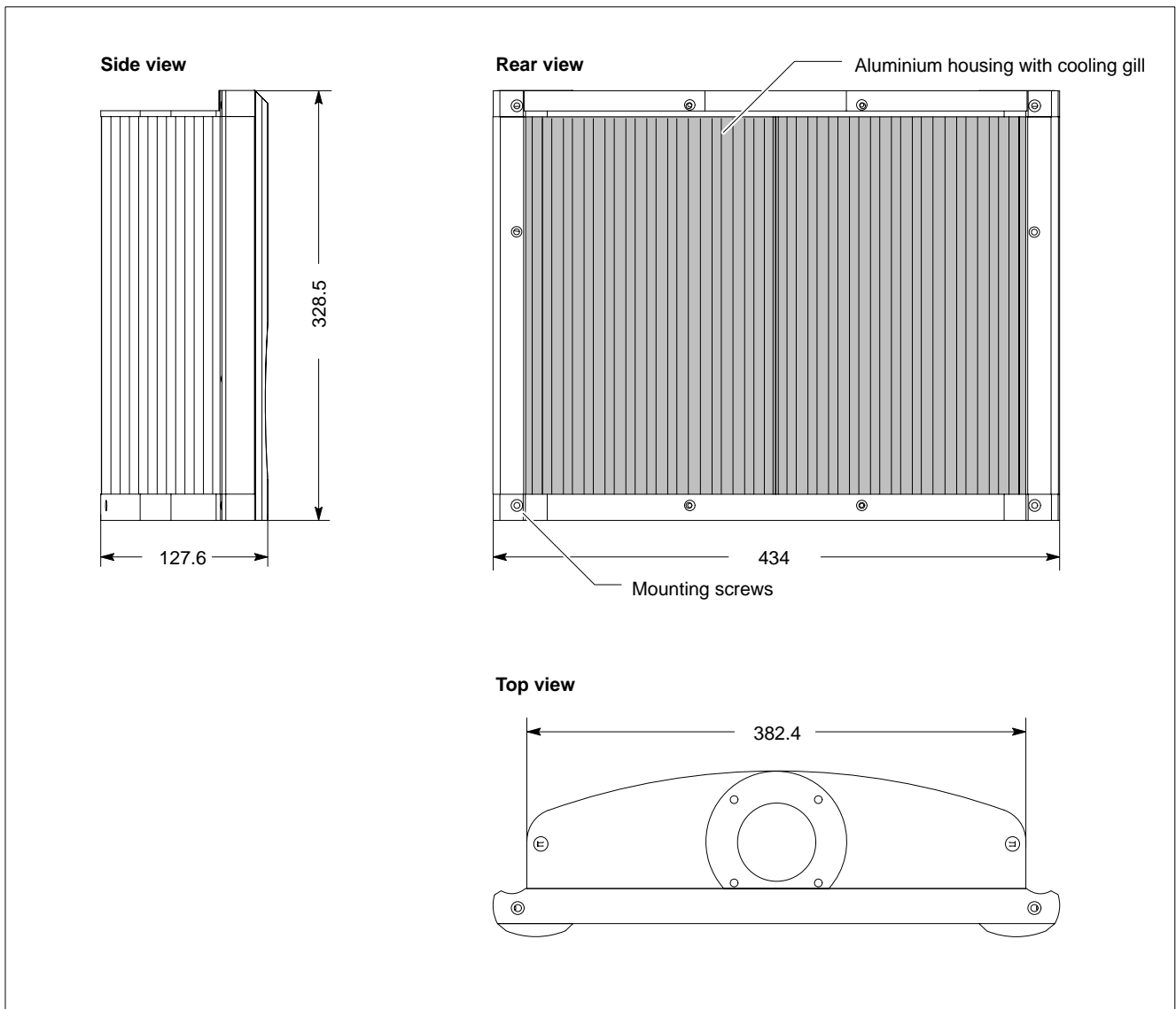

### 4.3 Mounting CPS21T with swivel/incline adapter

The CPS21T is planned for a:

- gallows mounting (e.g. bracket system KSE 60)

via an adjustable swivel/incline adapter.

For this, on the to side of the housing, there is a circular installation opening ( $\varnothing 60$  mm with 4 bore holes  $\varnothing 5$  mm), on which the swivel/incline adapter is fitted, and through which all cables are lead into the housing .

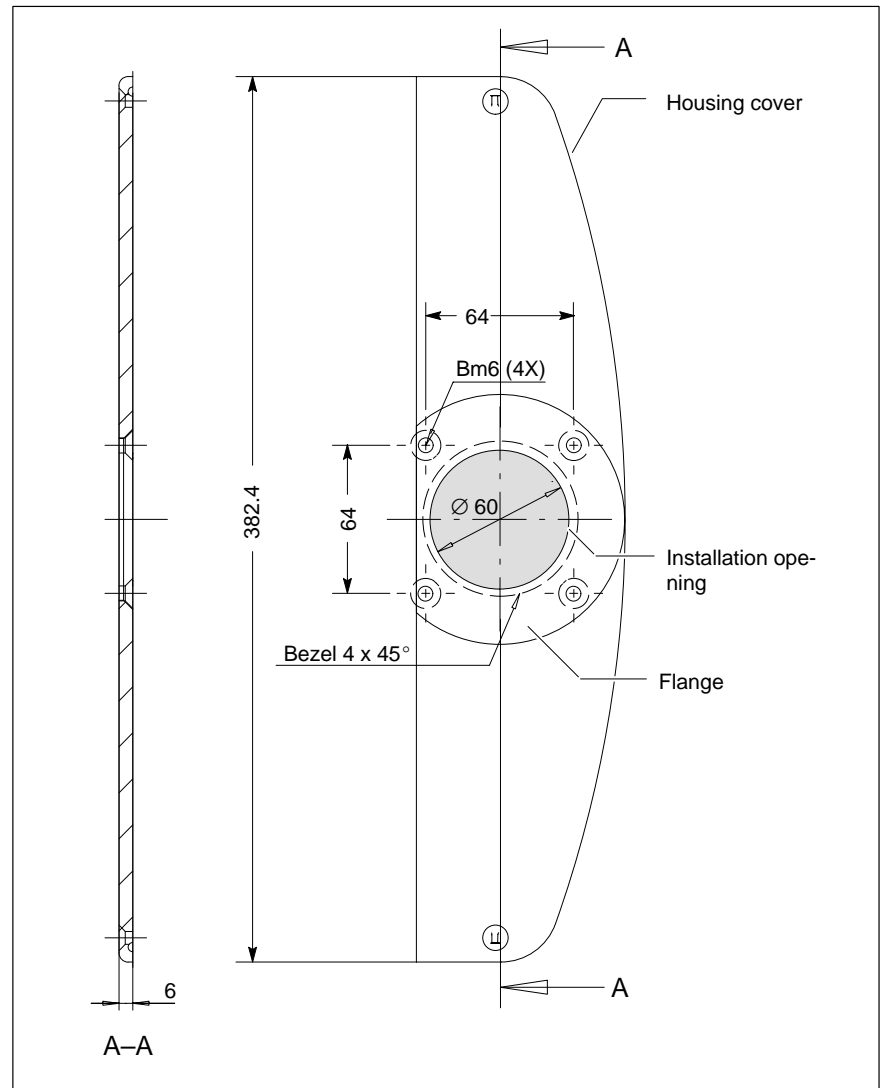

 **The flange for the gallows mounting must be sufficiently sealed in order to maintain the protection category IP 54.**

**Installation instructions**

- ★ For the gallows mounting, use the installation opening on the top side of the housing.
- ★ Pass the cables leading to the CPS21T and to the distribution circuit board (only CPS21T Version M) through the installation opening in the housing cover.
- ★ Fix the swivel/incline adapter of the swivel arm with 4 screws on the installation opening. The connections must be tight (IP 54).
- ★ Connect the cables to the corresponding connectors on the CPS21T and the distribution circuit board (Version M).
- ★ Close the housing.

## 5 Electrical connection



### CAUTION

Risk of damage to system components by insertion or removal of plug connectors on energized circuits!  
Connections must be made only while the system is switched off.

The control power is supplied 24 VDC power via X33 and X10\_1 interfaces.

### 5.1 24 VDC power supply



### DANGEROUS ELECTRICAL VOLTAGE

The 24 VDC input power must comply with the requirements for “protective separation”!

#### X33 24 VDC input

This port supplies:

- 24 VDC power to the control panel
- Required power for the backlight supply

Other functions can be found in chapter 6.7.

This assumes that the CPS21T control panel is connected to the IPC 300. IPC300 supplies the available voltage of 24 V available via IPC interface X11.

#### CPS21T

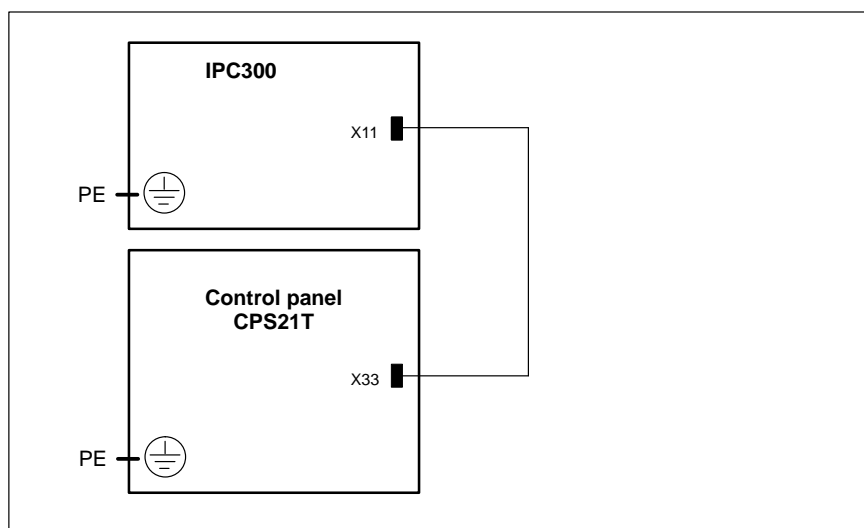

**X10\_1 24 VDC input**

The 24 V power supply is provided in case of





- CPS21T version I directly via X10\_1
- CPS21T version M via the X25 connector of the supply and distribution circuit board of the keypad. From X26, the 24 V power supply is connected to the X10\_1 connector.

X10\_1 is looped through for the fan power to X10\_2 (24 VDC output) .

Weidmüller push lock terminal, MSTB 1.5, 4 pin

Rated voltage: 24 VDC

Max. conductor cross section: 1,5 mm<sup>2</sup>

X10_1		Pin	Assignment
1		1	24V
2		2	24V
3		3	0V
4		4	0V

**X10\_2 24 VDC output**



The 24 VDC power supply X10\_2 is required by the housing fan which is integrated with the CPS21T. The fan is electrically connected in the works.

Weidmüller push lock terminal, MSTB 1.5, 3 pin

Rated voltage: 24 VDC

Fan connection ratings: 21.6 – 26.4 VDC; 1.1 W

Max. conductor cross section: 1,5 mm<sup>2</sup>

X10_2		Pin	Assignment
1		1	24 V
2		2	0 V
3		3	–



24 VDC power for housing fan.

CPS21T without keypad:

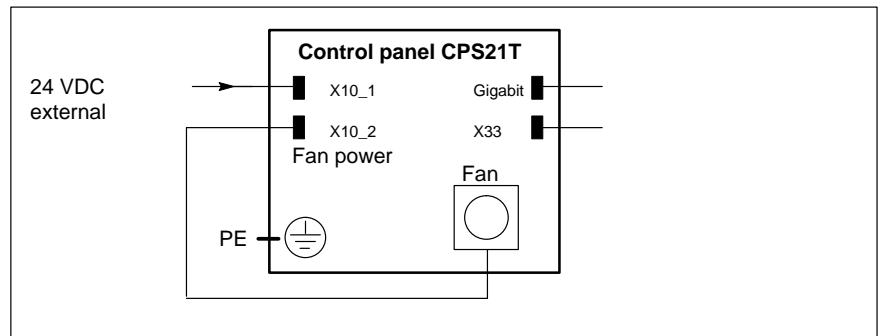

CPS21T with keypad:

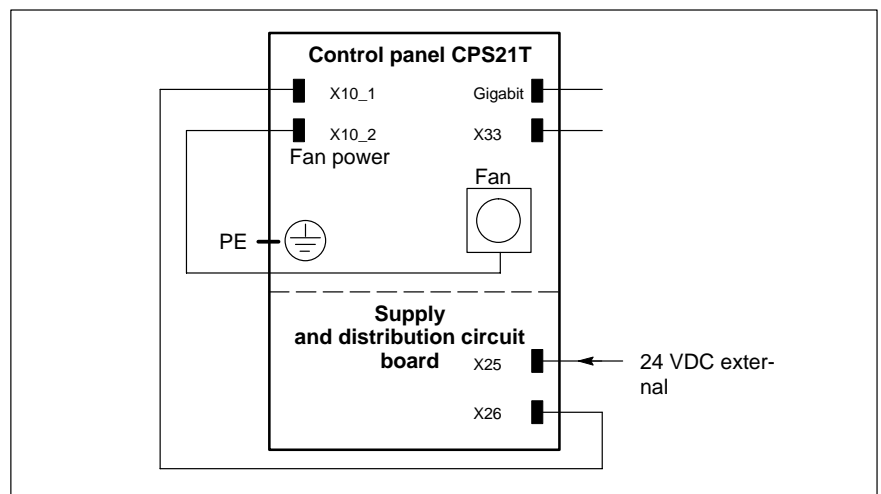

## 5.2 Control devices

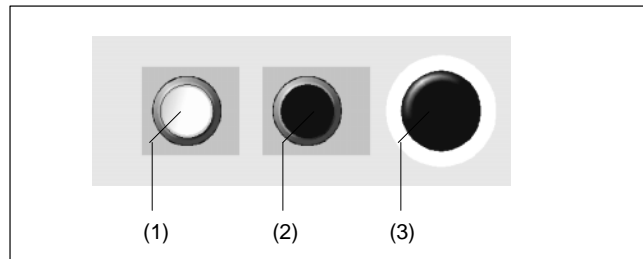

### (1) Pushbutton with lamp socket

Pushbutton, clear. Return to home initial position each time it is pressed.  
 2 break / make contact units; see specifications below.  
 Lamp sockets for lamps with max. 250 VAC/1.2 W rating.

#### Specifications

Operating voltage: 24 VDC / 2.75 A  
 240 VAC, 50 Hz / 3 A

Terminal cross section: 2 x 0.75...2.5 mm<sup>2</sup>,  
 2 x 0.75...1.5 mm<sup>2</sup> (with wire end ferrules)

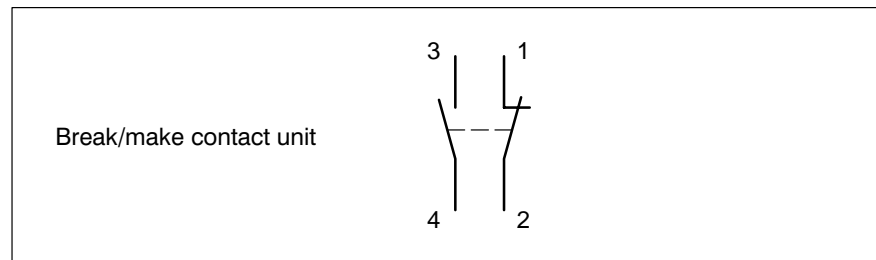

### (2) Pushbutton without lamp socket

Pushbutton, black. Return to home initial position each time it is pressed.  
 2 break / make contact units; see specifications below.

### (3) Emergency STOP button

Pushbutton for Emergency STOP functions as per EN 60 204, IEC 73, IEC 204, IEC 947, EN 60 947, VDE 0660 Part 200, VDE 0113 Part 1.  
 2 break / make contact units; see specifications below.

## 6 Interfaces

The ports and connectors are situated in the rear housing of the control panels.

### 6.1 Overview of ports and connectors

Panel label	Connector type, function:	connector type Physical	Mating connector or cable (external)
LCD	Gigabit: Video transmission – RS-422 serial interface for touch screen controller	Female RJ45 connector, 8 pin.	RJ45 connector, 8 pin, twisted pair, 8 core
Mouse	PS/2 mini DIN mouse port	Male mini DIN PS/2, Keyboard cable with	Male mini DIN PS/2, connector, 6 pin
KBD	PS/2 mini DIN keyboard con- nector	Male mini DIN PS/2, Keyboard cable with	Keyboard cable with Mini DIN PS/2 connector, 6 pin
X33	24V power supply, backlight power supply, mouse and keyboard signals, keyboard controller download	Female DB 15 connector	Male DB 15 connec- tor
24 Vout	Keyboard code output	pin Weidmüller	pin Weidmüller
Described in Section 5.1 of this manual:			
X10_1	24 VDC input	pin Weidmüller	pin Weidmüller
X10_2	24 VDC output power for housing fan	pin Weidmüller	pin Weidmüller

## 6.2 Port and connector layout

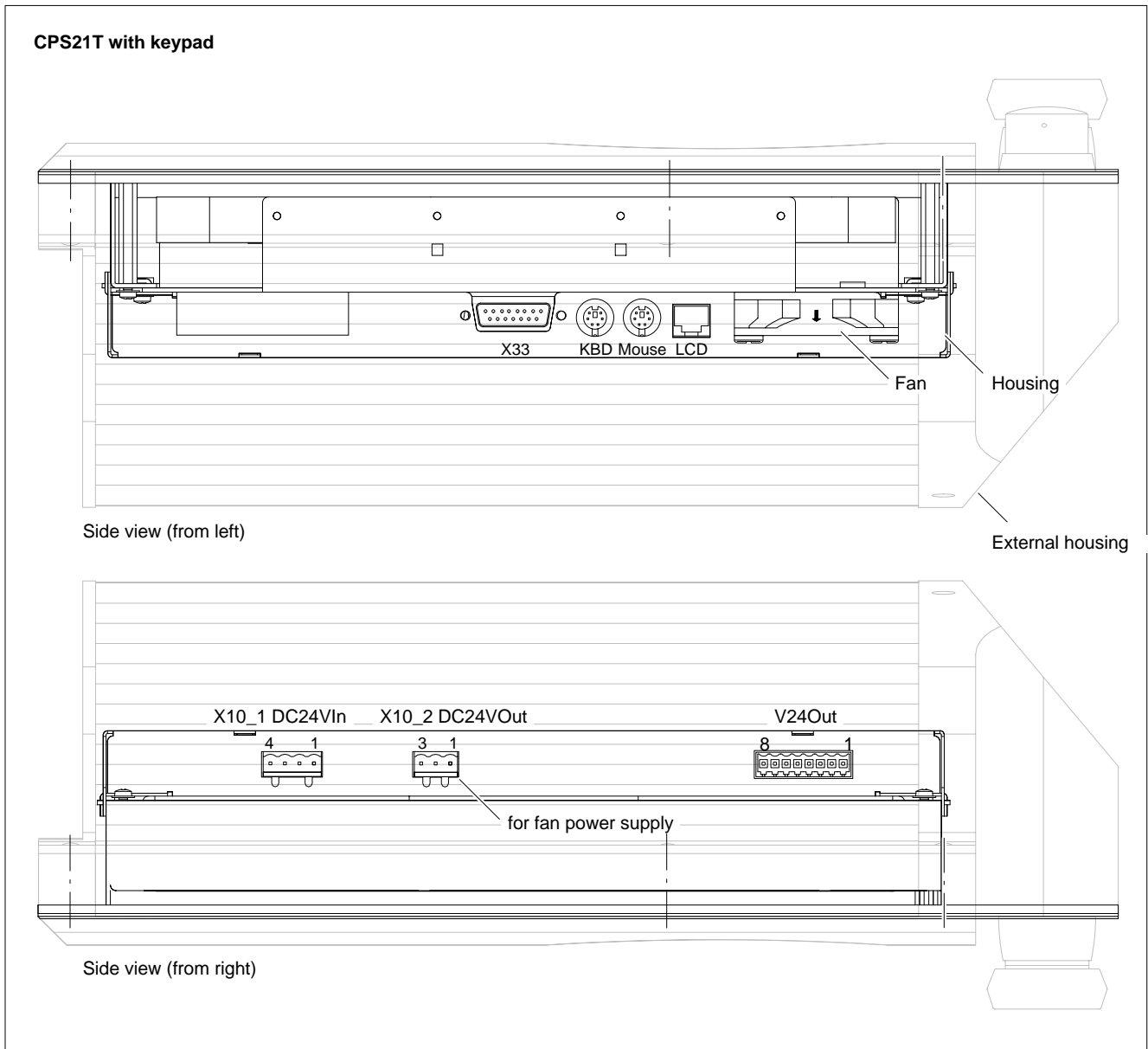

CPS21T without keypad

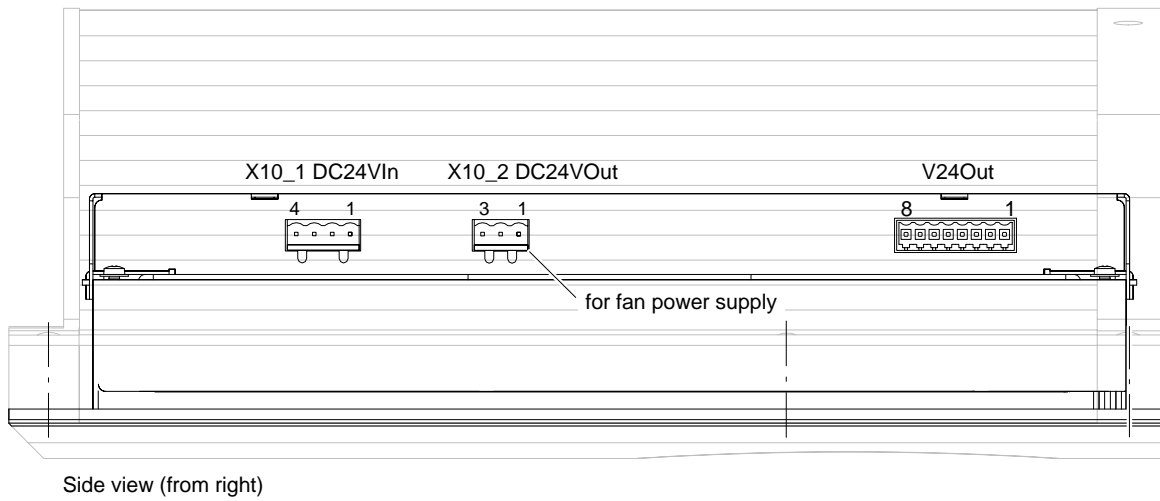
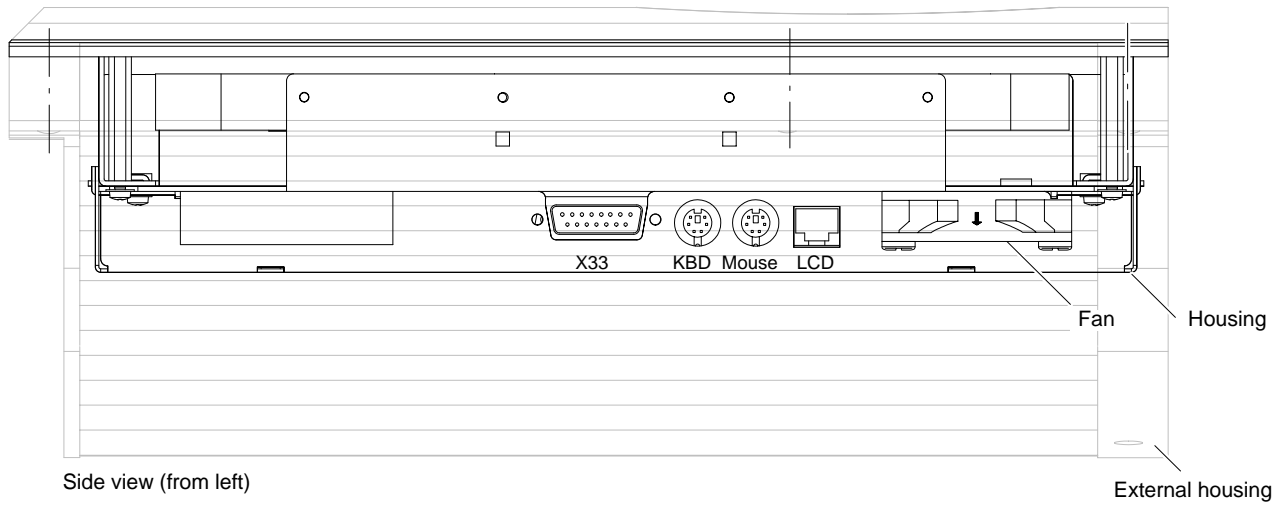

### 6.3 Supply and distribution circuit board (only CPS21T with keypad)

The supply and distribution circuit board in the CPS21T with the keypad must in any case be wired. Here, the following are to be connected:

- 24 VDC power connection
- all keys on the front panel (START, STOP, EMERGENCY-STOP)
- Distributor "key codes" on the front panel

X29 is **not** used when the external distributor cable is directly connected with the "V24Out" connector on the PC!

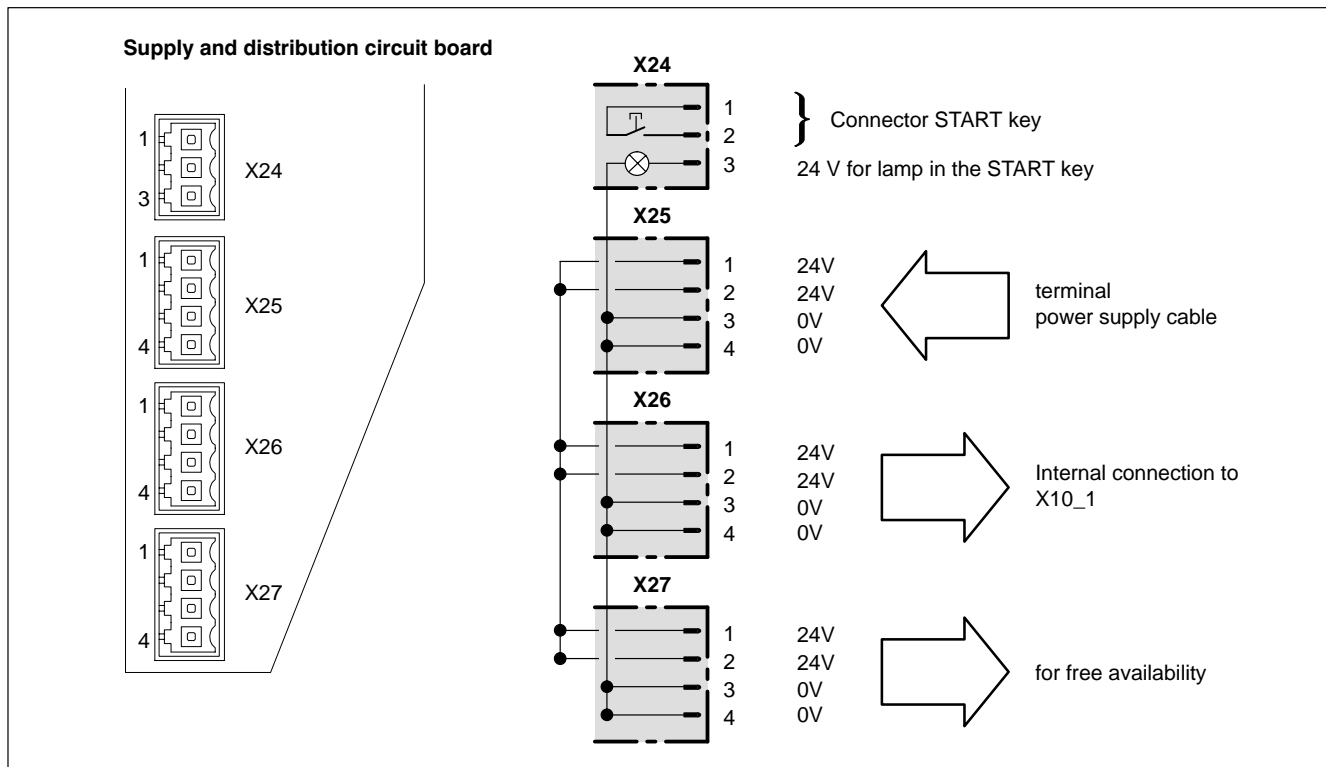

#### DANGEROUS ELECTRICAL VOLTAGE

Risk to life and considerable material damage due to faulty or not professionally installed EMERGENCY-STOP circuit!

Also integrate the EMERGENCY-STOP button of the CPS21T with the keypad in the EMERGENCY-STOP circuit!

**Supply and distribution circuit board**

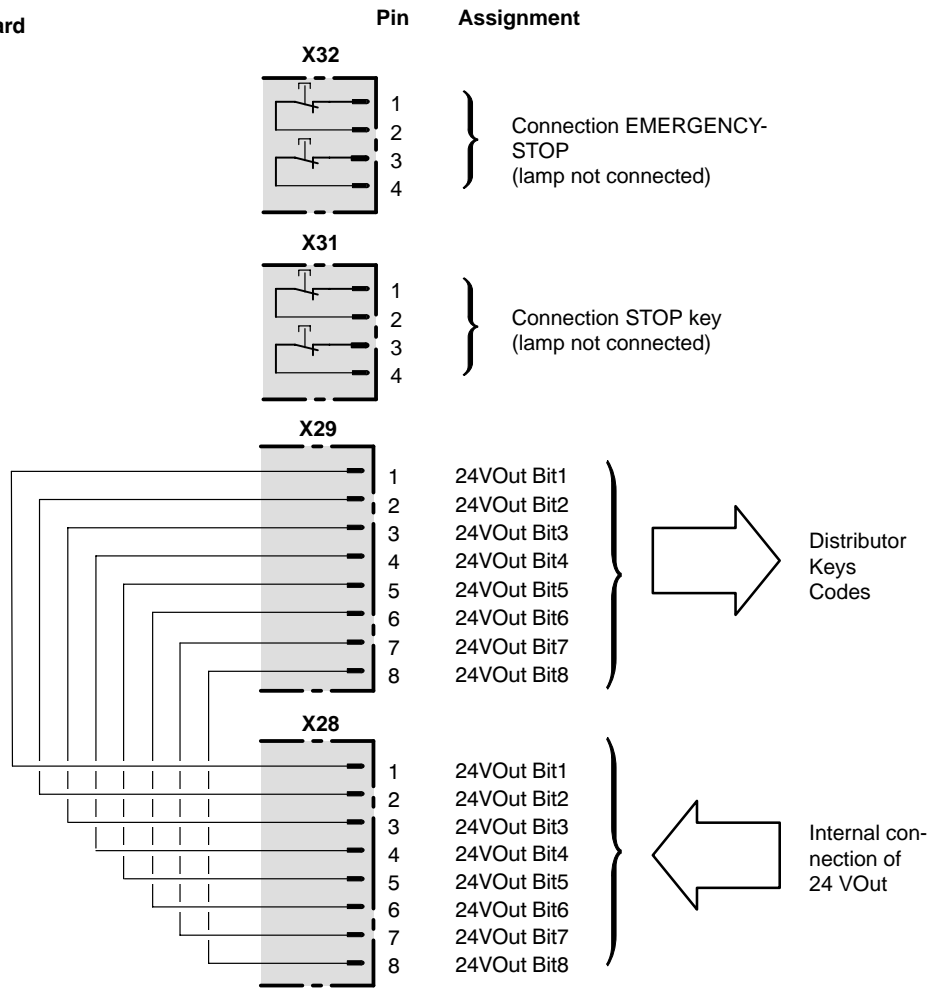
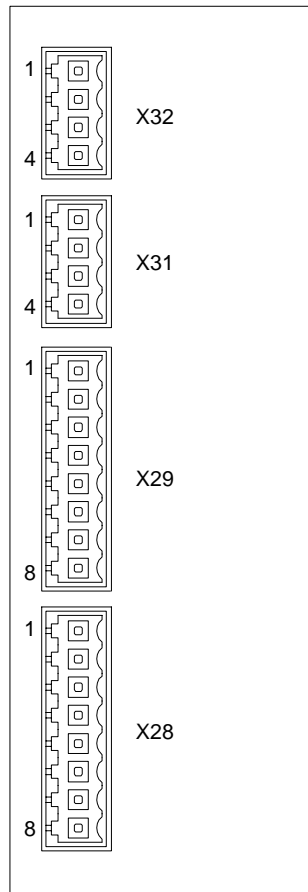

### Overview of connections in the CPS21T with keypad ex works:

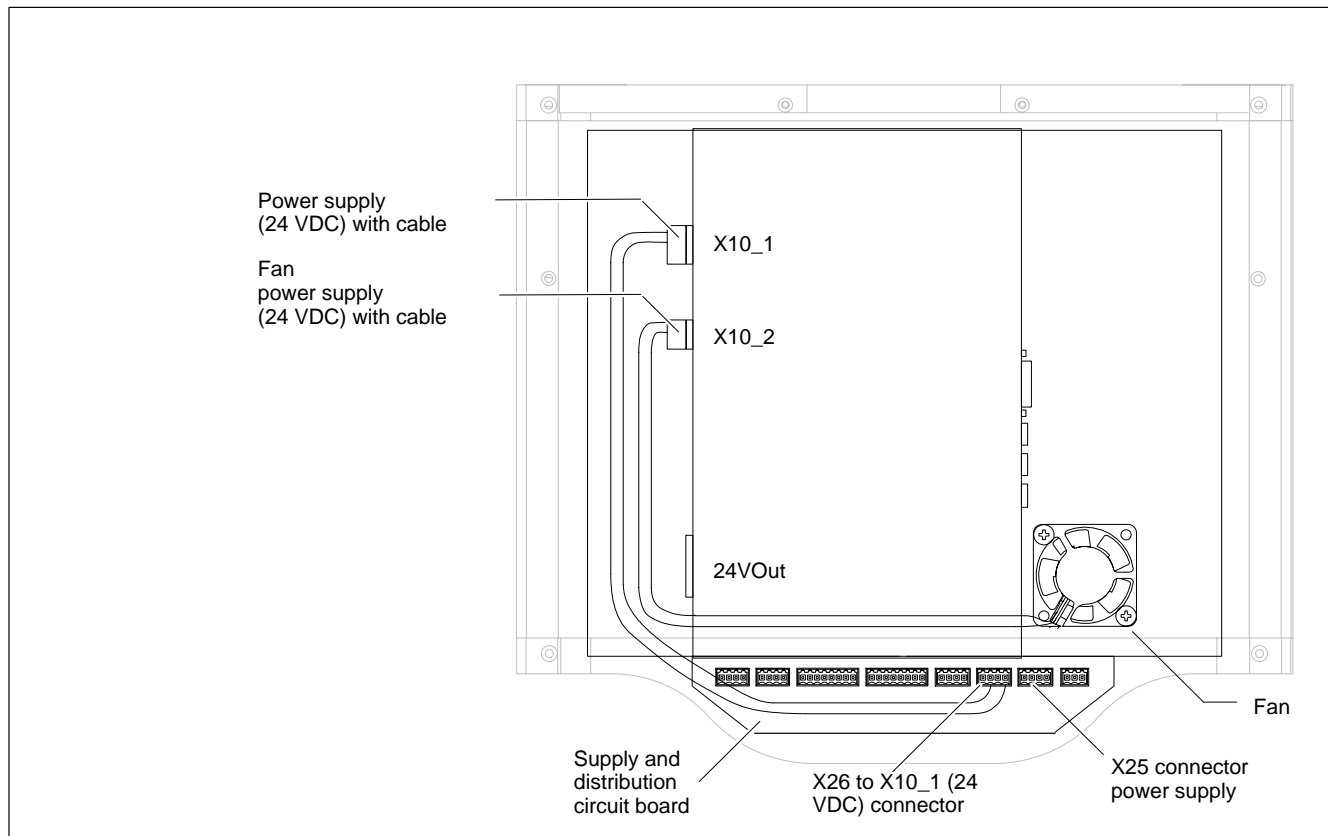

### Overview of connections in the CPS21T without keypad ex works:

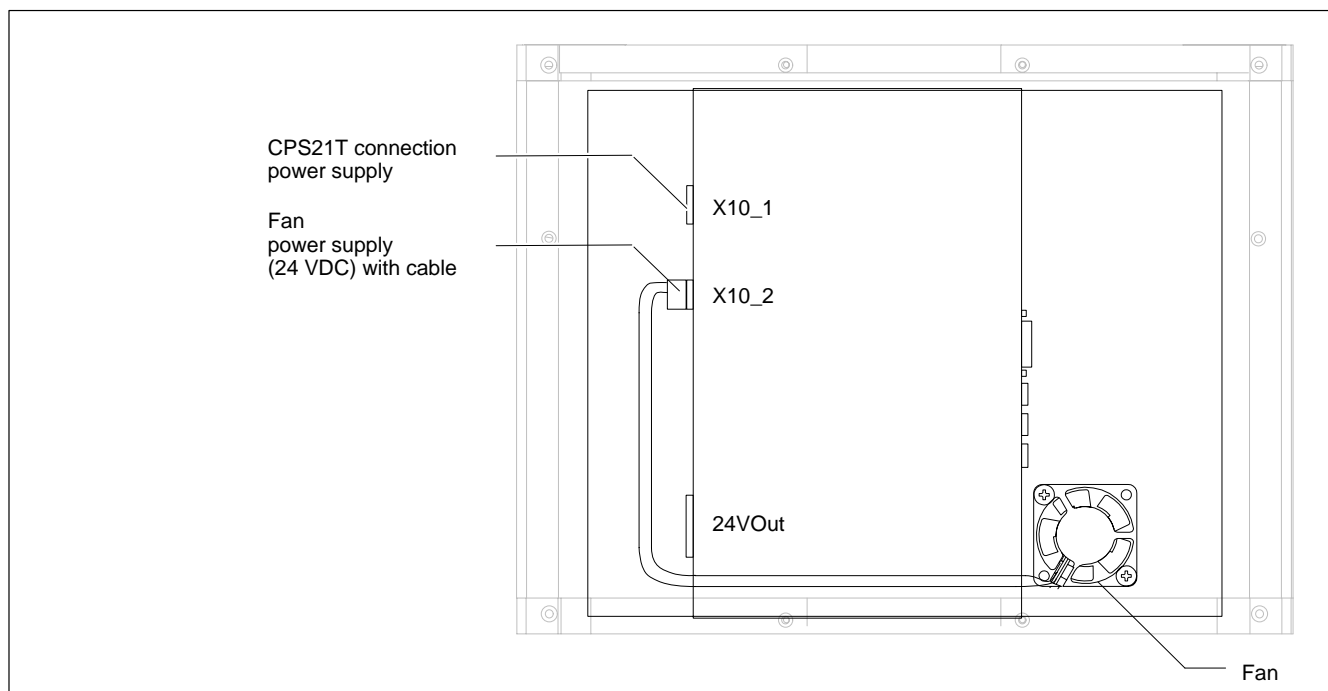



## 6.4 LVDS video signal interface

### LCD Gigabit interface

The Gigabit interface simultaneously handles the transfer of video signals and control communications for the touch screen controller (RS-422). On the IPC300 the controller signals are internally connected to COM2.

The Gigabit interface has been specifically designed for longer transmission routes and interference free transmission, and can only be connected to the Gigabit interface on the IPC300.

Female RJ45, 8 pin

Cable length: Max. 15 m, with repeater max. 75 m

Cable type: Twisted pair, 8 pin, screened

See also information on premanufactured connecting cables in Section 8.2.

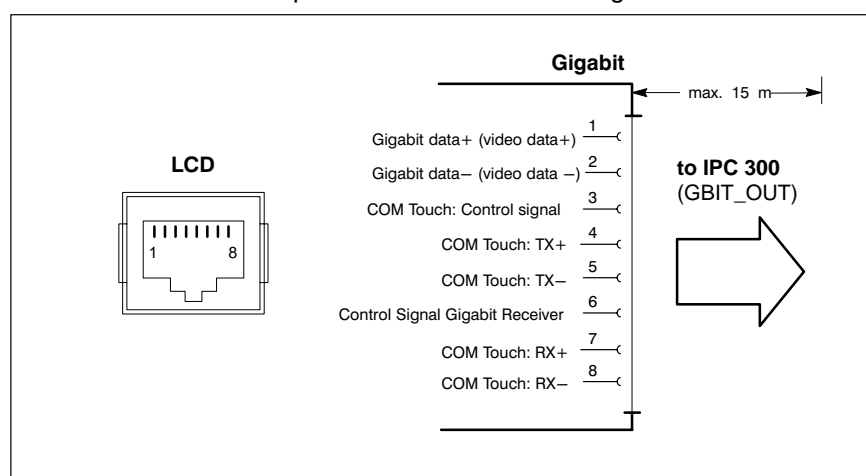

**Repeater GBIT**

The use of the Gigabit repeater extends the reach of required connections between the IPC300 and CPS21T (LCD and X33) by 15 m per repeater, to a maximum of 75 meters achieved with 4 repeaters. Installs via M4 press in nuts. Using standard mounting clamps, snap on installation on a standard DIN rail is also possible.

Refer to ordering information in Section 8.2.

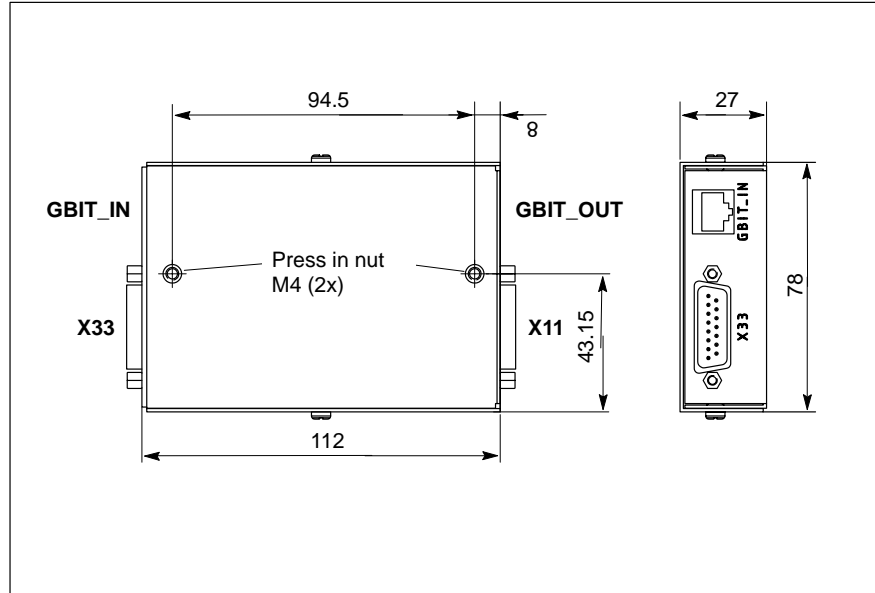

If necessary, display resolution must be set at 1024 x 768 Pixel in the repeater from the DIP switch S1 (refer to the following illustration).

To change display resolutions, switches 1 through 8 on the S1 DIP switch accessible in the housing can be set as follows:

- 1024 x 768 pixels

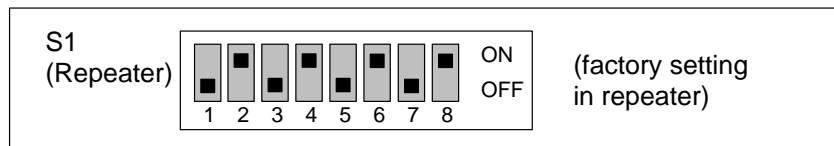

**6.5 Keyboard connector**

**KBD PS/2 mini DIN keyboard connector**

A keyboard with PS/2 mini DIN connector can be connected to this port.



**CAUTION**

An external keyboard is to be connected at the “KBD” interface of the CPS21T when the control panel is connected to a IPC 300. No keyboard may then be connected at the interface “Keyb” of the IPC 300. Otherwise, the keyboard signals may be faulty even if only one keyboard is used.

Female PS/2 mini DIN, 6 pin

Cable length: Max. 1.5 m

Cable type: Screened, min. cross-section 0.14 mm<sup>2</sup>

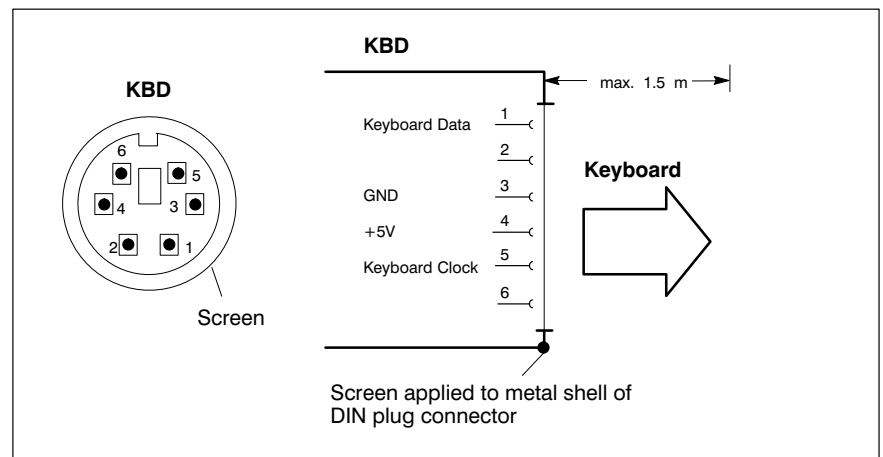

**Keyboard adapter**

In the event that the MF2 keyboard is equipped with a standard 5 pin DIN plug, you will require a keyboard plug adapter to a female PS/2 Mini DIN connector.

A suitable adapter is approx. 20 cm in length with a DIN connector and a mini DIN coupling on the ends. Connector assignment as per diagram below. These premanufactured adapters are available from computer stores.

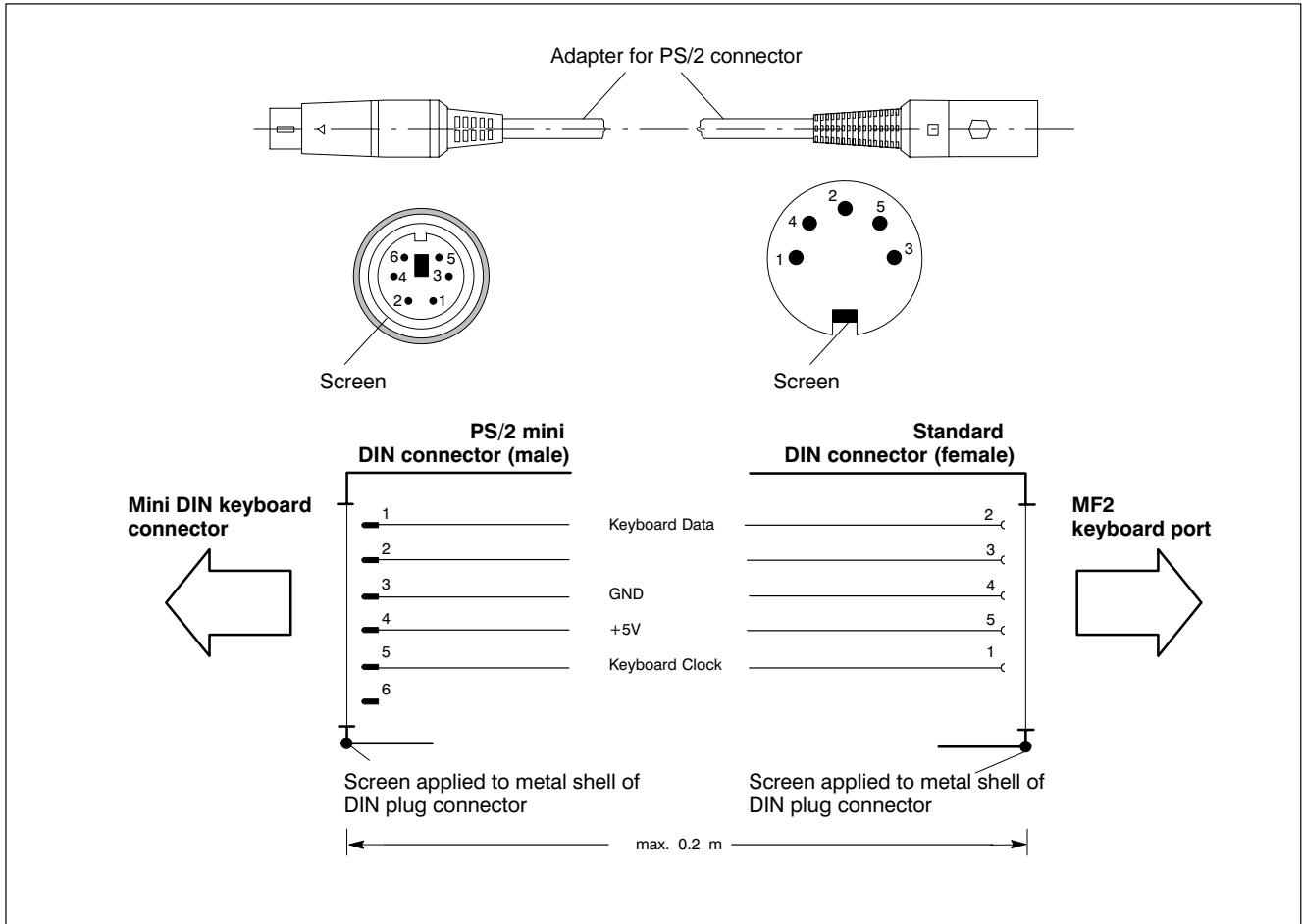

## 6.6 Mouse port

### Mouse PS/2 mouse port

A mouse with PS/2 mini DIN connector can be connected to this port.



#### CAUTION

An external mouse is to be connected at the CPS21T when the control panel is connected to a IPC 300. No mouse may then be connected at the interface "Mouse" of the IPC 300. Otherwise, the mouse signals may be faulty, even if only one mouse is used.

Female PS/2 mini DIN, 6 pin

Cable length: Max. 1.5 m

Cable type: Screened, min. cross-section 0.14 mm<sup>2</sup>

Interrupt (IRQ): 12

BIOS preset: IPC 300: PS/2 Mouse: Auto Detect

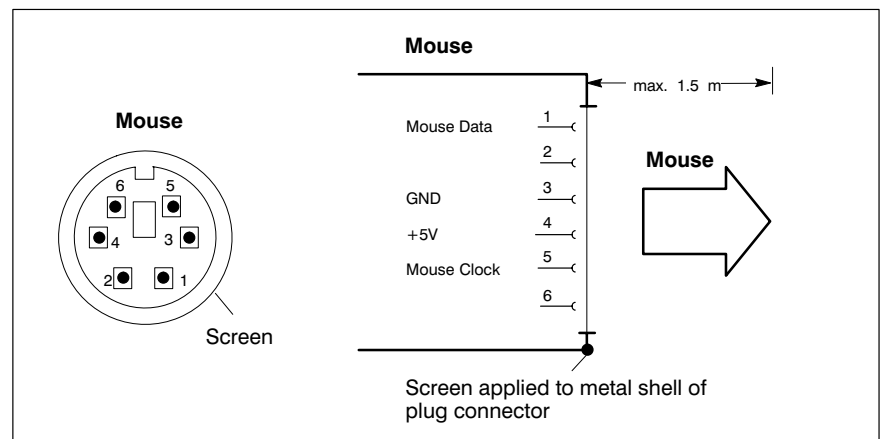

The operating system will not recognize the insertion of an external mouse after completed startup because the mouse initialization occurs during the boot phase.



**The connected mouse must be PS/2 compatible.**

The BIOS normally reserves IRQ12 for the PS/2 mouse. If there are address conflicts, e.g., if IRQ 12 has already been occupied by another PC expansion card, you should change the IRQ of the expansion card to one that is still free.

## 6.7 X33 power supply input

### X33 24 V power supply, backlight power supply, mouse and keyboard signals, keyboard controller download

The X33 power supply connection is connected to X11 on the IPC 300. It ensures a **faultless** operation of the control panel with the connected components, even over an extended distance (15 m).

This port supplies:

- 24 VDC power to the control panel
- Required power for the backlight supply
- Transmission of mouse and keyboard signals (also refer to sections 6.5 and 6.6) and
- the software download for the keyboard controller via the integrated V24 interface.

Female DB 15 connector

Cable length:

IPC300: Max. 15 m, can be extended to 75 m via repeaters in conjunction with Gigabit interface (refer to page 6-8)

Cable type:

Screened, min. cross-section 0.14 mm<sup>2</sup>

See also information on premanufactured connecting cables in Section 8.2.

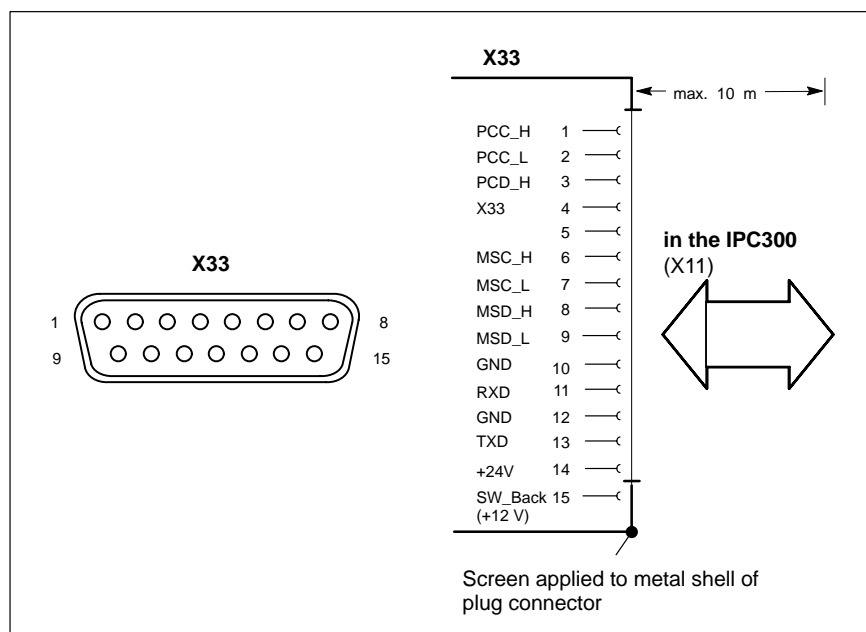

## 6.8 24 VOut-interface

### 24 VOut output key codes

The key codes of the navigation keys on the front panel are passed on to the outputs of the 24 VOut-interface. From there, they can be read through an external input link for further processing.

Weidmüller lock terminal, 8 pin.

Screen size 3.5 mm

Cable length:

Max. 20 m

Cable type:

Screened, min. cross section 0.14 mm<sup>2</sup>

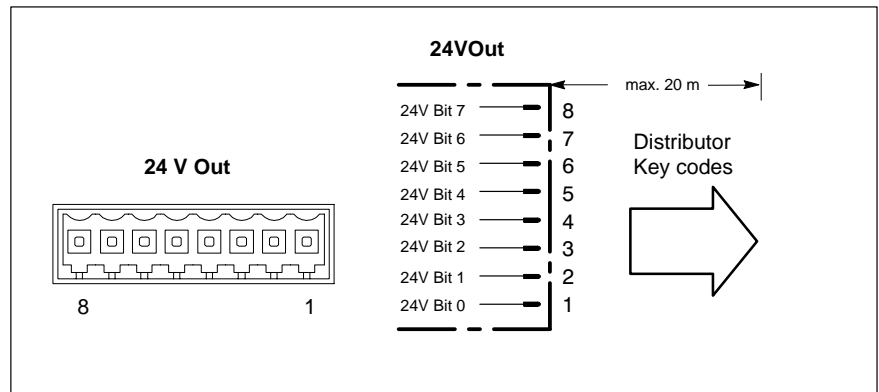

Notes:



## 7 Maintenance and replacement

The control panel CPS21T is maintenance-free. However, some components are subject to wear and must be replaced.

### 7.1 Maintenance schedule

Include the following tasks in your maintenance schedule

- Clean the surface of the screen at least once a week with an anti static cloth or window cleaning agent containing denatured alcohol.



#### CAUTION

**Dissolution of sealed key panel surface and display seal through contact with solvents!**

**Do not use any solvents (e.g., paint thinner)!**

- 
- At least once a year check that all plug and socket and terminal connections of the components are correctly seated and not damaged. Check that cables are not broken or crushed. Replace damaged parts immediately.
  - Check fan and fan filter mats at least once a year. Clogged and contaminated filter mats reduce the air volumes required for proper ventilation and cooling. Therefore, wash dirty filter mats in soapy water or replace with new mats. Allow washed filter mats to dry thoroughly before reinstalling.



#### DANGER

**Risk of injury through rotating fan impeller!**

**Keep hands and fingers clear, and do not insert any items into the fan impeller.**

---

 **Functional compatibility of spare parts is guaranteed for a minimum of 5 years.**

## 7.2 Replacing the backlight and display



### CAUTION

**Danger to the module!**

**All ESD protection measures must be observed when using the module! Prevent electrostatic discharges!**

### Removal and installation

The display and backlight unit of the **CPS21T** can be replaced **independent of each other**.

To install and remove, the control panel must be removed completely.

1. For reasons of safety, interrupt the power supply to the connected Bosch IPC300. Remove all connectors from the control panel and from the supply and distribution circuit board (only CPS21T with keypad). Also remove all protective conductor connections to the housing.
2. Loosen the mounting screws on the housing cover. Remove the housing frame with the display unit from the housing cover.
3. Loosen the front panel from the CPS21T housing frame (refer to the illustration on page 7-2).
4. After loosening the cover retaining screws, you can open the cover of the sheet metal housing on the rear of the control panel (refer to the illustration on page 7-2).
5. Remove the ribbon cables from the display connector, and remove the display housing frame including display and backlight unit in a sideways direction.

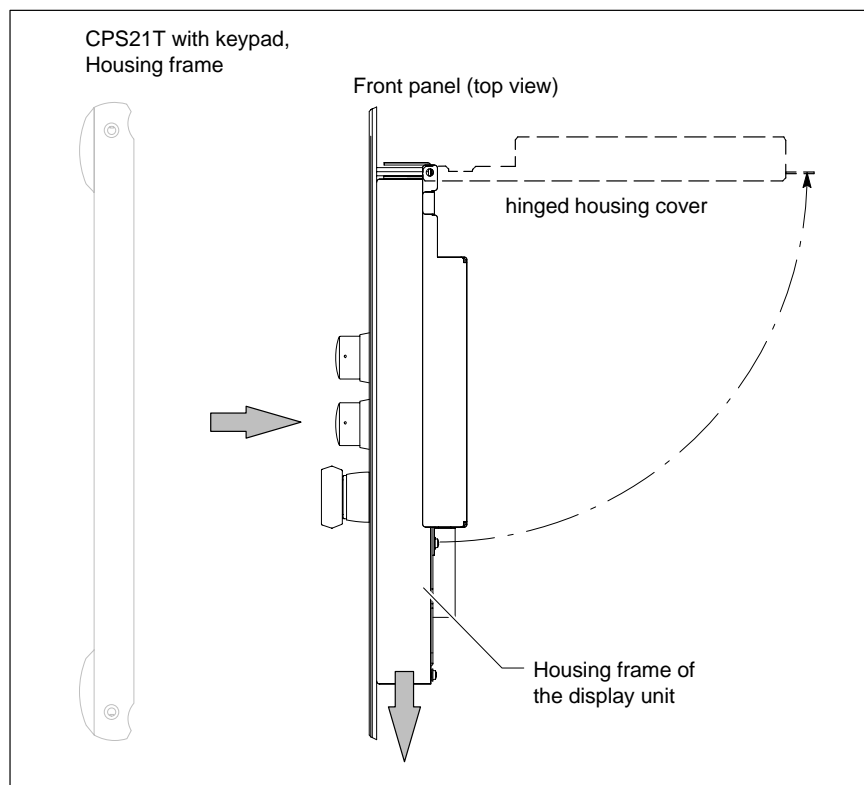

6. Loosen/remove the retaining screws for the display, disconnect the backlight from the mount, and replace it with a new one.
- 

**CAUTION****Use only the same type of displays!****Ensure that the backlight is compatible with the display!**

- 
7. Installation is in reverse sequence to disassembly described above.
  8. In the event that, subsequent to the installation, the display does not produce an image, check for the following:
    - proper seating and positive contact of display ribbon cable
    - proper seating and positive contact of backlight unit
    - proper seating of all reconnected connectors.

Notes:

## 8 Ordering Numbers

### 8.1 Control panels

Designation		Order no.
CPS21T with keypad	Touchscreen 15 in. TFT, with navigation keys and keypad (w/o connecting cables)	1070 083 221
CPS21T without keypad	Touchscreen 15 in. TFT, without navigation keys and keypad (w/o connecting cables)	1070 085 399

### 8.2 Accessories

Designation		Order no.
Connecting cables CPS21T	LCD, length	2.5 m 1070 918 793
		5 m 1070 919 258
		10 m 1070 918 794
		15 m 1070 079 384
	LCD, hi flex cable length	2.5 m 1070 920 456
		5 m 1070 921 385
		10 m 1070 921 384
		15 m 1070 921 070
	X33, length	2.5 m 1070 083 120
		5 m 1070 083 119
		10 m 1070 080 744
		15 m 1070 079 383
Repeater for CPS21T	Cable extension by 15 m, for LCD and X33	1070 079 423

Notes:

# A Appendix

## A.1 Index

### Numbers

24 Vout output, 6–13

### A

adapter, MF2 to PS/2 mini DIN (keyboard), 6–10

Air gap / creeping distance, 2–3

ambient temperature, 2–3

### B

backlight, disabling, 3–3

Bracket system, 4–5

### C

Code assignment, LED and key designation, 3–6

Components, 2–3

connecting cables, 8–1

control devices, 5–4

Keypad, 3–4

CPS21T

with keypad, 2–2

without keypad, 2–2

### D

display, touch screen, 3–1

TFT display, display resolution, 3–1, 6–8

TFT flat screen display, 3–1

display elements, 3–1

display resolution, Setting, 3–2, 6–8

Documentation, 1–7

### E

electrical connection

12 VDC power supply, 5–1

control devices, 5–4

EMC Directive, 1–1

EMERGENCY–STOP, 6–4

Emergency–STOP button, 5–4

EMERGENCY–STOP devices, 1–5

ESD

Electrostatic discharge, 1–6

grounding, 1–6

workplace, 1–6

ESD-sensitive components, 1–6

### F

Fan power, 5–2

### G

Gallows mounting, 4–5

GBIT repeater, 6–8

Gigabit, 6–7

Grounding bracelet, 1–6

### H

hardware, versions, 2–2

Housing fan, 5–2

### I

impact resistance, 2–4

installation, 4–5

dimensions, 4–3

installed positions, clearances, 4–2

interfaces, 6–1

24 Vout output, 6–13

LCD, 6–7

LVDS video signals, 6–7

overview, 6–1

Position, 6–2

PS/2 keyboard connector, 6–8

PS/2 mouse port, 6–11

Supply and distribution circuit board, 6–4

X33, 6–12

### K

Keyboard

Controller, 3–5

Software download, 3–7

Transferring key codes

to the 24 Vout output, 3–5

via MF2, 3–5

User-defined assignment, 3–7

Keypad, control devices, 3–4

Keys, Scanning front panel keys, 3–5

### L

LED and key designation, 3–6

Low-Voltage Directive, 1–1

### M

maintenance schedule, 7–1

Modules sensitive to electrostatic discharge. See ESD-sensitive components

Mounting with swivel/ incline adapter, 4–5

mouse port, 6–11

### N

Navigation keys , 3–4

### O

operating conditions, 2–3

**P**

Protection Category, 2–4  
PS/2 keyboard port, 6–8  
PS/2 mini DIN to MF2 keyboard adapter, 6–10  
PS/2 mouse port, 6–11

**Q**

Qualified personnel, 1–2

**R**

relative humidity, 2–3  
replacements  
    Backlight, 7–2  
    display, 7–2  
    hardware components, 7–2  
Resistance, 2–4

**S**

Safety instructions, 1–4  
Safety markings, 1–3  
Spare parts, 1–5  
Standard operation, 1–1  
standards compatibility, 2–4  
START key, 6–4  
STOP key, 6–4  
storage temperature, 2–3  
Supply and distribution circuit board, 6–4  
    24 VDC power supply, 6–4  
    24 Vout outputs, 6–4  
    Connections ex works, 6–6  
    EMERGENCY–STOP, 6–4  
    START key, 6–4  
    STOP key, 6–4  
system overview, 2–1

**T**

temperature, 2–3  
Test activities, 1–5  
touch screen, 3–2  
    Drivers, 3–1  
Trademarks, 1–7

**V**

vibration resistance, 2–4

**X**

X33, power supply input, 6–12



# Bosch Automation Technology

---

## Australia

Robert Bosch (Australia) Pty. Ltd.  
Head Office  
Cnr. Centre - McNaughton Roads  
P.O. Box 66  
AUS-3168 Clayton, Victoria  
Fax (03) 95 41 77 03

## Great Britain

Robert Bosch Limited  
Automation Technology Division  
Meridian South Meridian Business Park  
GB-LE3 2WY Braunstone  
Leicestershire  
Fax (01 16) 28-9 28 78

## Canada

Robert Bosch Corporation  
Automation Technology Division  
6811 Century Avenue  
CAN-Mississauga, Ontario L5N 1R1  
Fax (905) 5 42-42 81

## USA

Robert Bosch Corporation  
Automation Technology Division  
Fluid Power Products  
7505 Durand Avenue  
USA-Racine, Wisconsin 53406  
Fax (414) 5 54-81 03

Robert Bosch Corporation  
Automation Technology Division  
Factory Automation Products  
816 East Third Street  
USA-Buchanan, MI 49107  
Fax (616) 6 95-53 63

Robert Bosch Corporation  
Automation Technology Division  
Industrial Electronic Products  
40 Darling Drive  
USA-Avon, CT 0 60 01-42 17  
Fax (860) 4 09-70 80

We reserve the right to make technical alterations

Your concessionary

# BOSCH



Robert Bosch GmbH  
Geschäftsbereich  
Automationstechnik  
Antriebs- und Steuerungstechnik  
Postfach 11 62  
D-64701 Erbach  
Fax +49 (0) 60 62 78-4 28