

DIAX04 HDD and HDS Drive Controllers 1st Generation

Project Planning

DOK-DIAX04-HDD+HDS****-PRJ2-EN-P

Titel	DIAX04 HDD and HDS Drive Controllers 1st Generation
Type of documentation	Project Planning
Document type code	DOK-DIAX04-HDD+HDS****-PRJ2-EN-P
Internal file reference	<ul style="list-style-type: none"> • 209-0074-4304-02
The purpose of this documentation	<p>This documentation serves</p> <ul style="list-style-type: none"> • to develop the electro-construction • to assist in mounting the drive controller into the control cabinet • to assist in the installation of the drive package

Änderungsverlauf

Document designation of previous editions	Status	Comments
DOK-DIAX04-HDD+HDS****-PRJ1-EN-P	11.96	first release
DOK-DIAX04-HDD+HDS****-PRJ1-EN-P	05.97	error correction
DOK-DIAX04-HDD+HDS****-PRJ2-EN-P	07.98	revision (serial interface)

Copyright © INDRAMAT GmbH, 1998

Copying this document and giving it to others, and the use and communication of the contents hereof, are forbidden. Offenders are liable for the payment of damages. All rights reserved in the event of a patent or the registration of a utility model or design (DIN 34-1).

Validity All rights are reserved with respect to the content of this documentation and the availability of the product.

Published by INDRAMAT GmbH • Bgm.-Dr.-Nebel-Str. 2 • D-97816 Lohr a. Main
Telefon 09352/40-0 • Tx 689421 • Fax 09352/40-4885

Dept. ECD (RS/JR)

Note This document is printed on chlorine-free bleached paper.

Contents

1 Introducing the System	1-1
1.1 Drive Package - DIAX04	1-1
1.2 The individual components of the digital DIAX04 drive.....	1-2
1.3 Supply units.....	1-2
2 Drive controllers HDD / HDS	2-1
2.1 Configured drive controller	2-1
2.2 Drive controller, basic unit.....	2-2
2.3 Command communication module	2-2
2.4 Software module	2-2
2.5 Additional plugin module	2-2
2.6 Configuration type plate	2-4
2.7 Type codes of the configured drive controller	2-5
2.8 Technical data - an overview	2-7
3 Planning the control cabinet	3-1
3.1 Ambient conditions and Installation elevation	3-1
3.2 The use of coolers in the control cabinet	3-2
3.3 Dimensional sheets.....	3-5
3.4 Connection lines.....	3-10
3.5 Measures against interference sources in the control cabinet.....	3-11
4 Planning the electrical connections	4-1
4.1 General information	4-1
4.2 Connecting the basic unit.....	4-2
5 Accessories	5-1
5.1 LWLs (Fiber optic cables)	5-1
6 Transport and Storage	6-1
6.1 General instructions	6-1
7 Identifying the Merchandise	7-1
7.1 Delivery slip and barcode sticker	7-1
7.2 Type plate of the drive controller.....	7-2
7.3 Other type plates.....	7-2
8 Mounting and installation	8-1

8.1 Mounting the drive controller 8-1
8.2 Installation 8-3

9 Service and Testing 9-1

9.1 Error diagnoses 9-1
9.2 Repairs and replacements 9-1
9.3 High voltage check and insulation check 9-2

10 Index 10-1

Customer Service Locations

1 Introducing the System

1.1 Drive Package - DIAX04

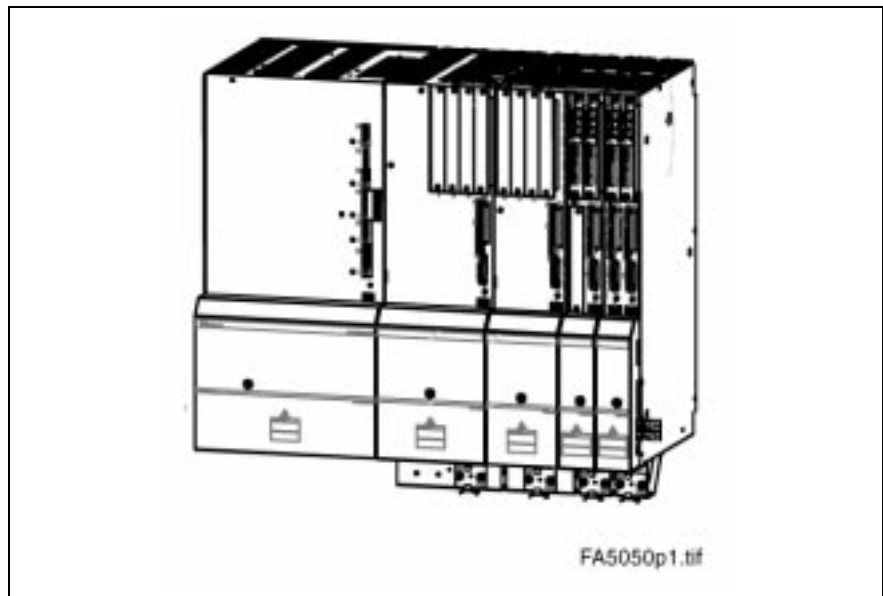

Fig. 1-1: Digital intelligent drive system - DIAX04

The modular concept of the DIAX04 INDRAMAT drive enables a flexible combination of AC drives to create compact drive packages implementing but one supply unit.

Together with MKD, MHD, 1MB and 2AD AC motors, HDD and HDS drives are rapid-response drives, suitable as servo and main drives, capable of being used in such tasks as machine tools, textile, printing and packaging machines, or in robotics and handling machines.

1.2 The individual components of the digital DIAX04 drive

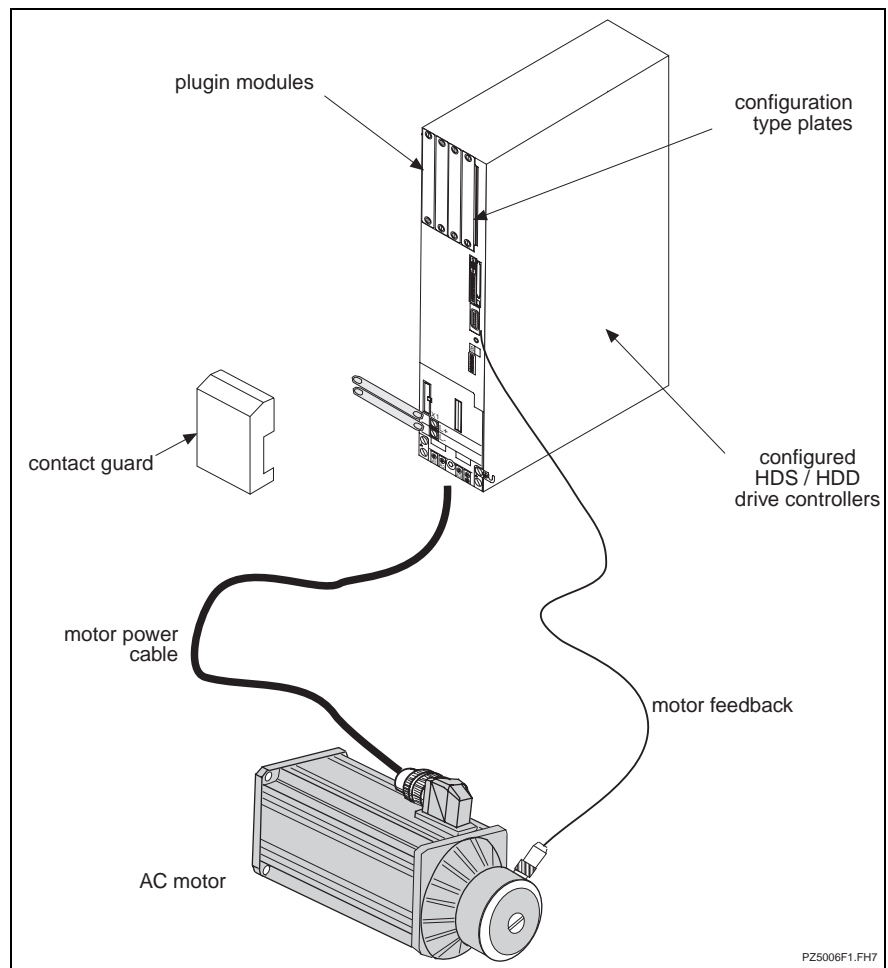

Fig. 1-2: Individual components of the digital drive

1.3 Supply units

HDD and HDS drive controllers are intended for connection to a HVE or HVR supply module. These modules supply all the signal and power voltages which the controller requires.

See also documentation "DOK-POWER*-HVE+HVR****-ANW*-EN-P"

2 Drive controllers HDD / HDS

2.1 Configured drive controller

The structure of the drive controllers is modular. The basic unit is adapted to a respective function by outfitting it with different plugin modules.

INDRAMAT supplies the drive controllers configured. The configuration is determined by the required functions.

A configured drive controller is made up of the following components:

- drive controller - basic unit
- command communications module
- software module
- additional plug-in modules (HDS only)
- configuration type plate

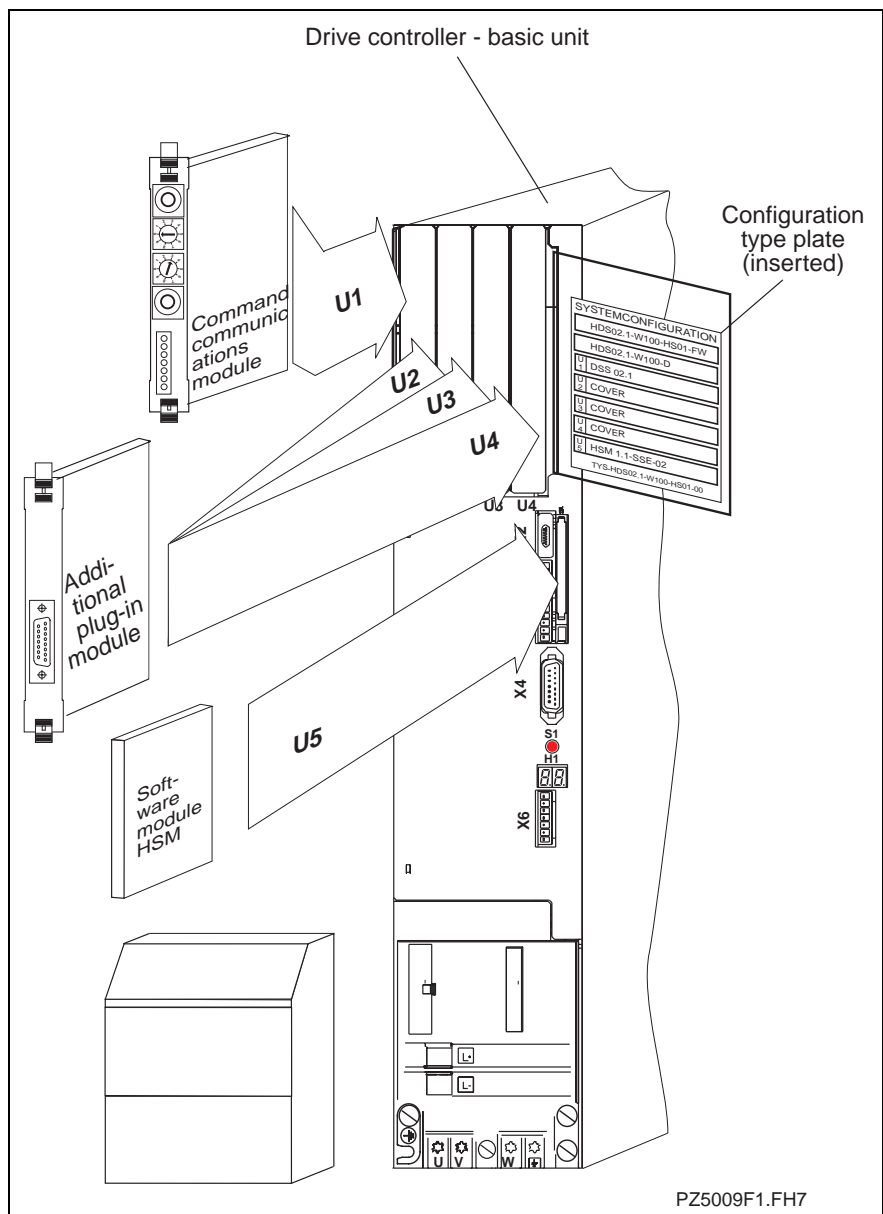

Fig. 2-1: Components of a configured drive controller

Drive controller HDD

The HDD drive controller is equipped to control two motors.

It is outfitted with two slots into which a command communications module for each axis can be inserted.

Due to the compact construction, the unit has no slots for additional plugin modules. This means that only motors capable of operating with a HSF or RSF motor feedback from INDRAMAT can be used. As a result, the drive controller is only suited for machine axes not requiring direct linear scales.

2.2 Drive controller, basic unit

The slots in the basic unit are empty.

2.3 Command communication module

The term "Command communication module" defines various plugin modules.

These plugin modules are the interface to the control.

The following command communication modules are available:

- SERCOS interface type DSS02.1M
- ANALOG interface type DAE02.1M

2.4 Software module

Type: HSM

The software module contains the firmware of the drive (operating software) and stores all drive parameters. The firmware depends on the selected configuration and the desired functions.

In the event that the unit must be replaced, the drive parameters can simply be transferred to the replacement unit by inserting the software module. The drive is then immediately available again with its specified features.

2.5 Additional plugin module

The following plugin modules are defined by the term "Additional plugin module":

Digital I/O cards

Type: DEA04.1M, DEA05.1M, DEA06.1M

Digital interface cards for a bidirectional exchange of data, e.g., with a PLC. Each interface has 15 inputs and 16 outputs. The individual types are differentiated in terms of the internally set address.

Type: DEA08.1M, DEA09.1M, DEA10.1M

Type: DEA28.1M, DEA29.1M, DEA30.1M

Every interface has 32 inputs and 24 outputs as well as a CLC Bb-output.

Interface card for different measuring systems

Type: DEF01.1M, DEF02.1M

for connecting incremental measuring systems with square-wave signal output

Type: DLF01.1M

for connecting incremental measuring systems with sinusoidal signal output

Type: DFF01.1M

for connecting singleturn GDS 1.1 measuring systems

Type: DAG01.2M

for connecting multiturn absolute encoders with SSI signal output

Type: DZF02.1M, DZF03.1

for connecting INDRAMAT gear-type encors

Type: DRF01.1M

for connecting measuring systems with analog output signals (e.g., resolver; maximum input voltage: +/-10V)

Note: Only one plugin module, i.e., a DLF, DZF or DRF may be used at one time. It is not possible to combine these cards!

Interface card

Type: DAK01.1M

The "ARCNET coupler card" is a plug-in card for use with the CLC-D control card and represents the interface to an ARCNET bus system.

Type: DAK02.1M

The DAQ02 plug-in module is a plug-in card for use with the CLC-D contro card. With it, it is possible to link several CLCs in an application implementing several master axes.

This link can be a simple system, i.e., a primary ring only, or a redundant system, i.e., both a primary and secondary ring.

Type: DSA01.1M

The plug-in module "Absolute encoder emulator" generates absolute actual position values that correspond to SSI standards (Synchronous serial interface).

Integrable control

Type: CLC-D02.3M

Supports a centralized control of digital drive controllers in SYNAX applications. (For details see document "SYNAX - Synchronization of Machine Axes".)

Note: All plugin modules are described in detail in the document "Plugin modules for digital intelligent drive controllers"; doc. type DOK-DIAX04-PLUG*IN*MOD-PRJ2-EN-P.

2.6 Configuration type plate

The configuration type plate records the type designations of

- the configured drive controller
- the basic unit
- the software module
- and the plugin modules in slots U1 to U4

These type designations help identify which components are in which slots.

In the event of a problem, these type designations on the configuration type plate can be used to quickly identify the replacement parts needed.

Note: The configuration type plate identifies the modules the drive controller is equipped with. Prior to startup, check to make sure that the drive controller is equipped with what is listed on the plate.

Any changes in the configuration should also be noted on the configuration type plate!

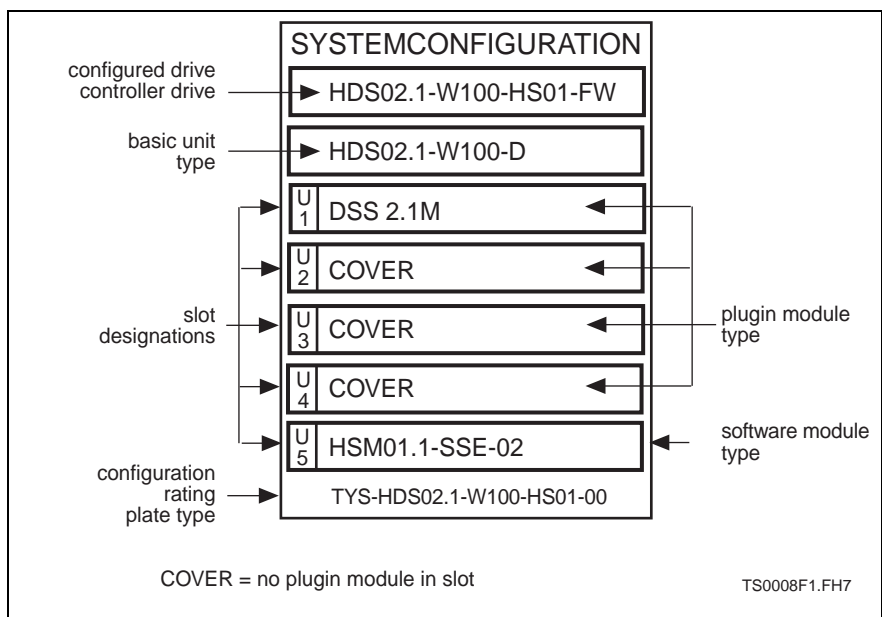

Fig. 2-2: An example of a configuration type plate

2.7 Type codes of the configured drive controller

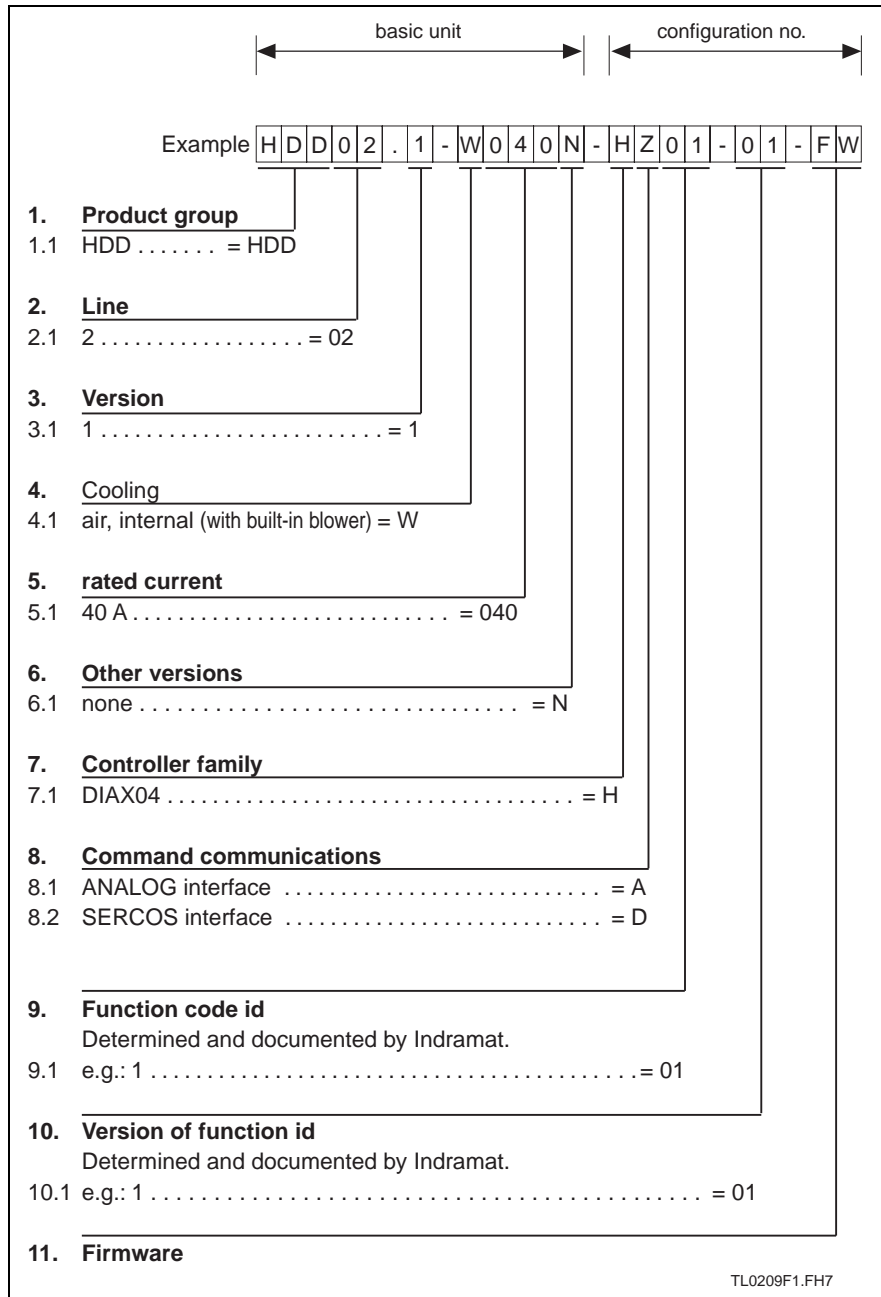

Fig. 2-3: Type codes HDD

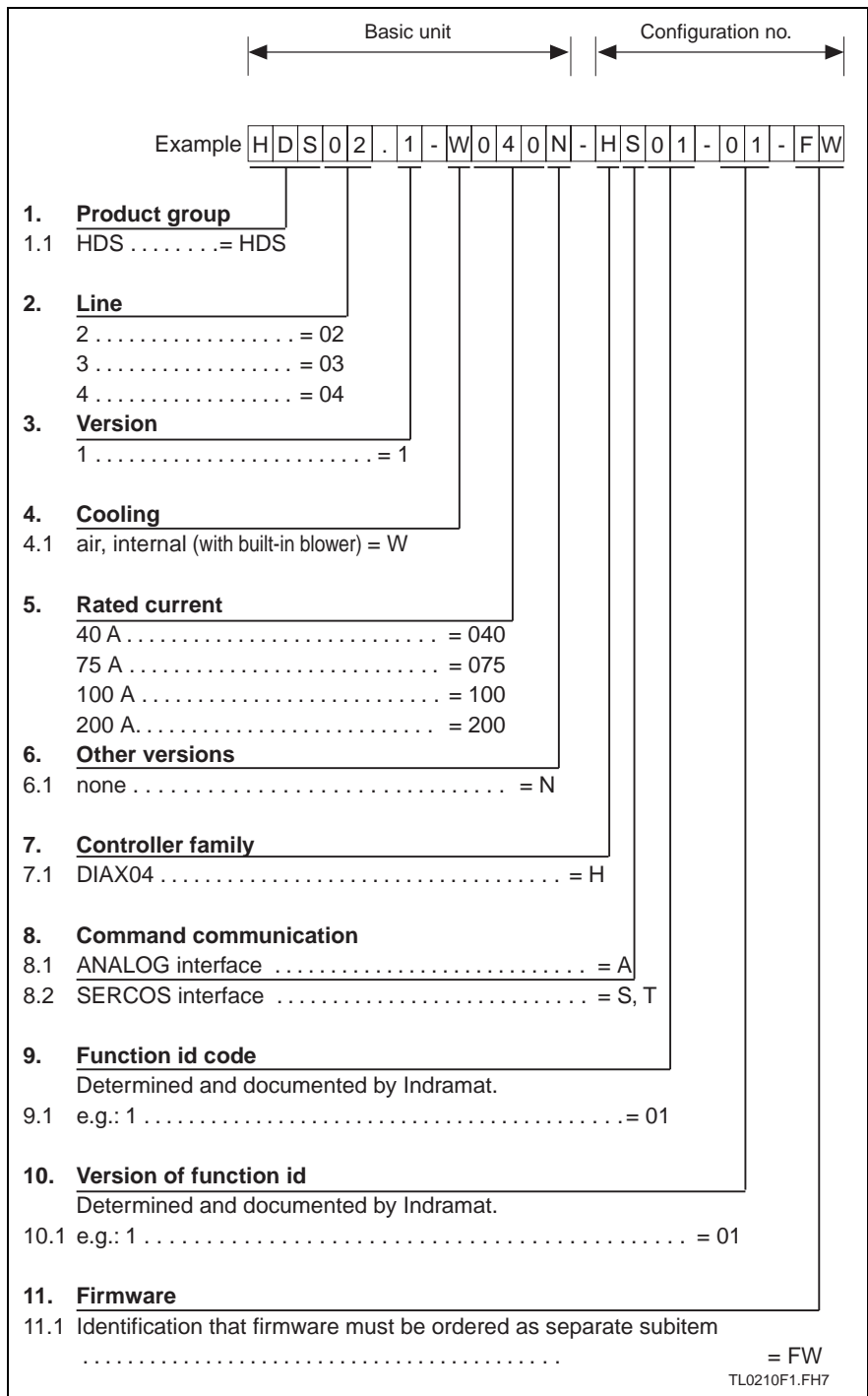

Fig. 2-4: Type codes HDS

2.8 Technical data - an overview

Designation	Symbol	Unit	HDD02.1- W040N	HDS02.1- W040N	HDS03.1- W075N	HDS03.1- W100N	HDS04.1- W200N
Rated current	I_{type}	A	40	40	75	100	200
Peak current	I_{peak}	A	40 per axis	40	75	100	200
Continuous current (4kHz/8kHz*)	I_{cont}	A	15 / 10 per axis	20 / 15	40 / 30	50 / 35	85 / 50
Power loss with I_{cont}	P_v	W	95 per axis	125	220	280	530
Weight	m	kg	8	7.5	11	11	14,5
Power consumption for signal processing from 24V-source **)	P_{24V}	W	40	20	20	20	20

*) Clock frequency of the power section

**) Basic unit only; plugin module (configuration) see Fig. 2-6

Ambient application conditions		
Permissible ambient temperature range with rated data	° C	+5 ... +45
Maximum permissible ambient temperature with derated data	° C	55
Storage and transport temperature	° C	-30 ... +85
Installation elevation without reduction of rated data	meters above sea level	max. 1000
Insulation classification		C as per DIN VDE 0110
Protection category		IP 10 per DIN 40 050

Fig. 2-5: Technical data of HDD and HDS

Power consumption of the
plugin modules

Plug-in module type	Power consumption (in W)
CLC-D02.3M-FW	6,0
DAE02.1M	1,2
DAG01.2M	3,3
DAK01.1M	2,1
DAQ02.1M	3,0
DBS03.1M-FW	3,0
DEA04.2M	1,6
DEA05.2M	1,6
DEA06.2M	1,6
DEA08.1M	1,6
DEA09.1M	1,6
DEA10.1M	1,6
DEA28.1M	1,6
DEA29.1M	1,6
DEA30.1M	1,6
DEF01.1M	4,5
DEF02.1M	4,5
DFF01.1M	3,6
DLF01.1M	5,4
DRF01.1M	3,4
DSA01.1M	8,0
DSS02.1M	1,5
DPF05.1M-FW	1.2
DZF02.1M	5,9
DZF03.1M	5,9

Fig. 2-6: Power consumption of the plug-in modules

3 Planning the control cabinet

3.1 Ambient conditions and Installation elevation

- Rated data** The rated data of the controllers apply to
- ambient temperature of +5° to +45° C
 - Installation elevations of 0 to 1000 meters above sea level.

Exceeding rated data If the controllers are to be used outside of the indicated range, then it is necessary to take the "Load factors" into consideration. This reduces the output data.

⇒ In such cases as these, check whether the output data suffice for your application. To determine the load factors, please see Fig. 3-1. Values for temperature and installation exceeding those indicated are not permissible!



WARNING

Damage to units and loss of guarantee!

⇒ Controllers operated outside of specified ambient conditions could be damaged. The guarantee is also forfeited in such cases.

⇒ Please, therefore, note the following instructions!

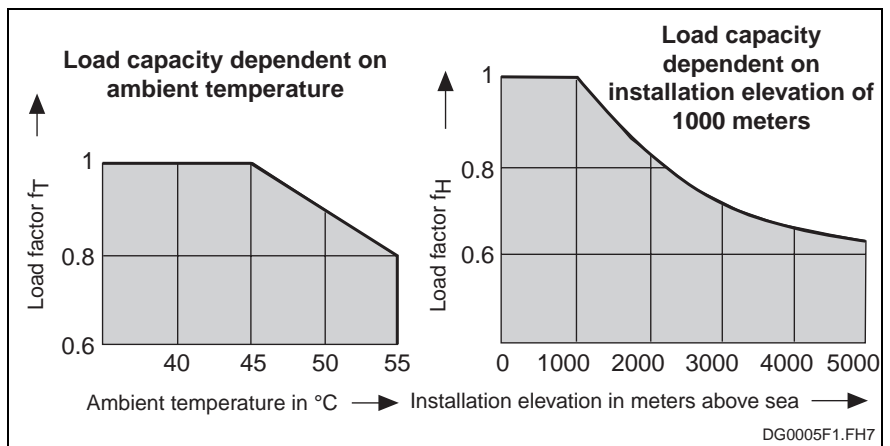

Fig. 3-1: Load factors as dependent on ambient temperature and installation elevation

If **either** the ambient temperature **or** the installation elevation exceed rated data:

⇒ Multiply the rated data listed in the technical data with the determined load factor.

⇒ Ascertain that the derated data does not exceed your application.

If **both** the ambient temperature **and** the installation elevation exceed rated data:

⇒ Multiply the determined load factors f_T and f_H .

⇒ Multiply the resulting value with the rated data of the controller listed in the technical data.

⇒ Ascertain that the derated data is not exceeded by your application.

Protection category The controller satisfies protection category IP10 as per EN 60 529, edition dated 10.91 (DIN VDE 0470-1).
It has been designed for mounting into a control cabinet or closed housing (as per DIN VDE 0160, ed. 05.88, section 5.5.1.3 and 6.5.1.3).

Note: The control cabinet construction must also take the applicable safety guidelines on protection against contact into account (for industrial equipment, see, e.g., EN 60204/DIN VDE 0113, Section 1)

3.2 The use of coolers in the control cabinet

The controller may only be operated without a reduction of rated data up to an ambient temperature of 45° C. Resultingly, it may be necessary to use a cooler.



CAUTION

Damage to controller is possible!

The operating safety of the machine is at risk.
⇒ Note the following instructions!

Avoid dripping or spraying water

The use of coolers results in condense water. The following instructions must therefore be complied with:

- Coolers must always be arranged so that condense water cannot drip onto the electronic equipment within the control cabinet.
- Coolers must be placed so that the condense water collecting on the blower of the cooler is not sprayed onto electronic equipment.

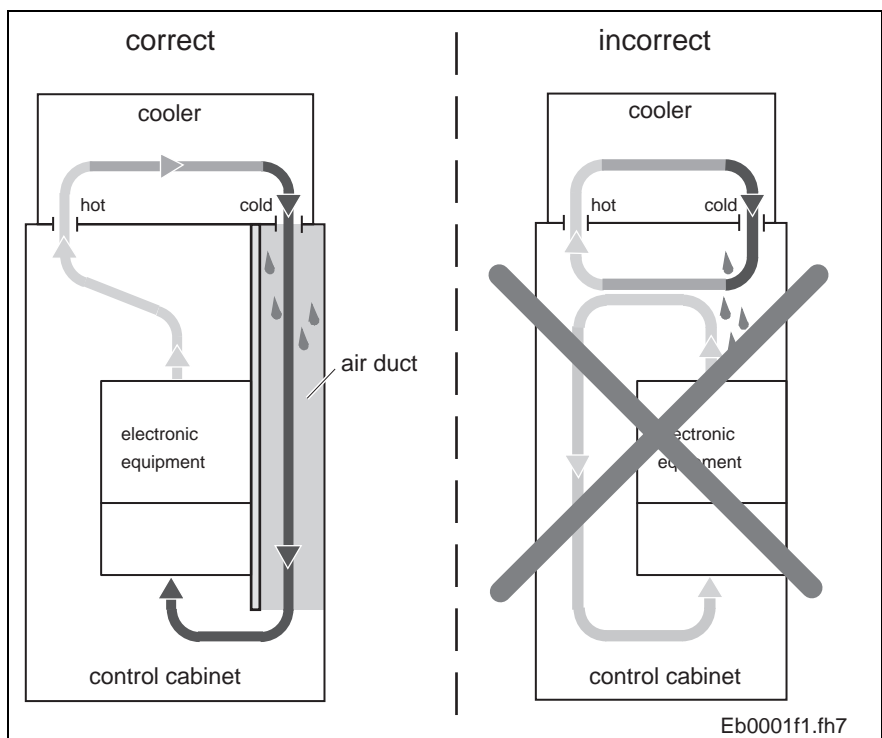

Fig. 3-2: Arranging the cooler on the control cabinet

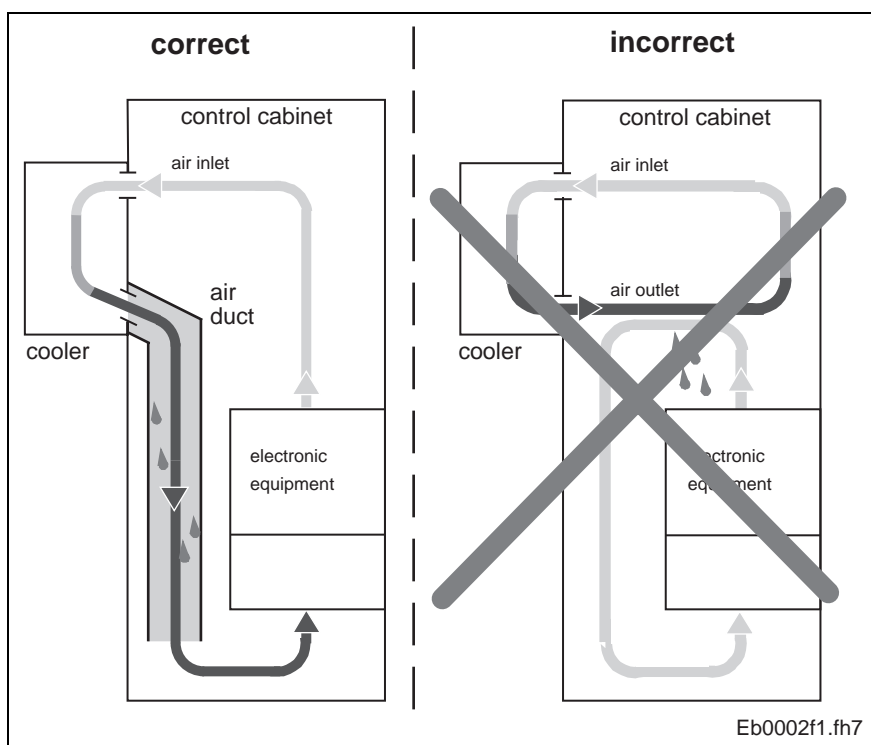

Fig. 3-3: Arranging the cooler on the front of the control cabinet

Avoiding condensation

- Coolers must be set at 40° C and no lower!
- Coolers with self-adjusting temperature must be set so that the inside temperature of the control cabinet is not lower than that of outside. Temperature limit must be set at 40° C!
- Use only well-sealed control cabinet to avoid formation of condensation by humid air entering the cabinet.
- If control cabinet must be operated with doors opening (startups, servicing, etc.), then it must be ensured that, after the doors are closed, the controller is at no time cooler than the air in the cabinet. This could cause condensation. It is, therefore, necessary to run the cooler even when the machine is off until the temperature of the air inside the control cabinet and that of the installed units is the same.

3.3 Dimensional sheets

Mounting rails with type designation SUP-M01-HD (Part number: 271274) should be used to fasten the drive controller into the control cabinet. It is only available in a length of 750 mm and must be shortened as needed at delivery.

The mounting rails are screwed onto the mounting panel. Screwing it into every other slot is sufficient to fasten it into place.



CAUTION

Unit can be damaged as a result of incorrect mounting orientation!

Danger of overheating.

⇒ Operate units in the mounting orientations indicated only.

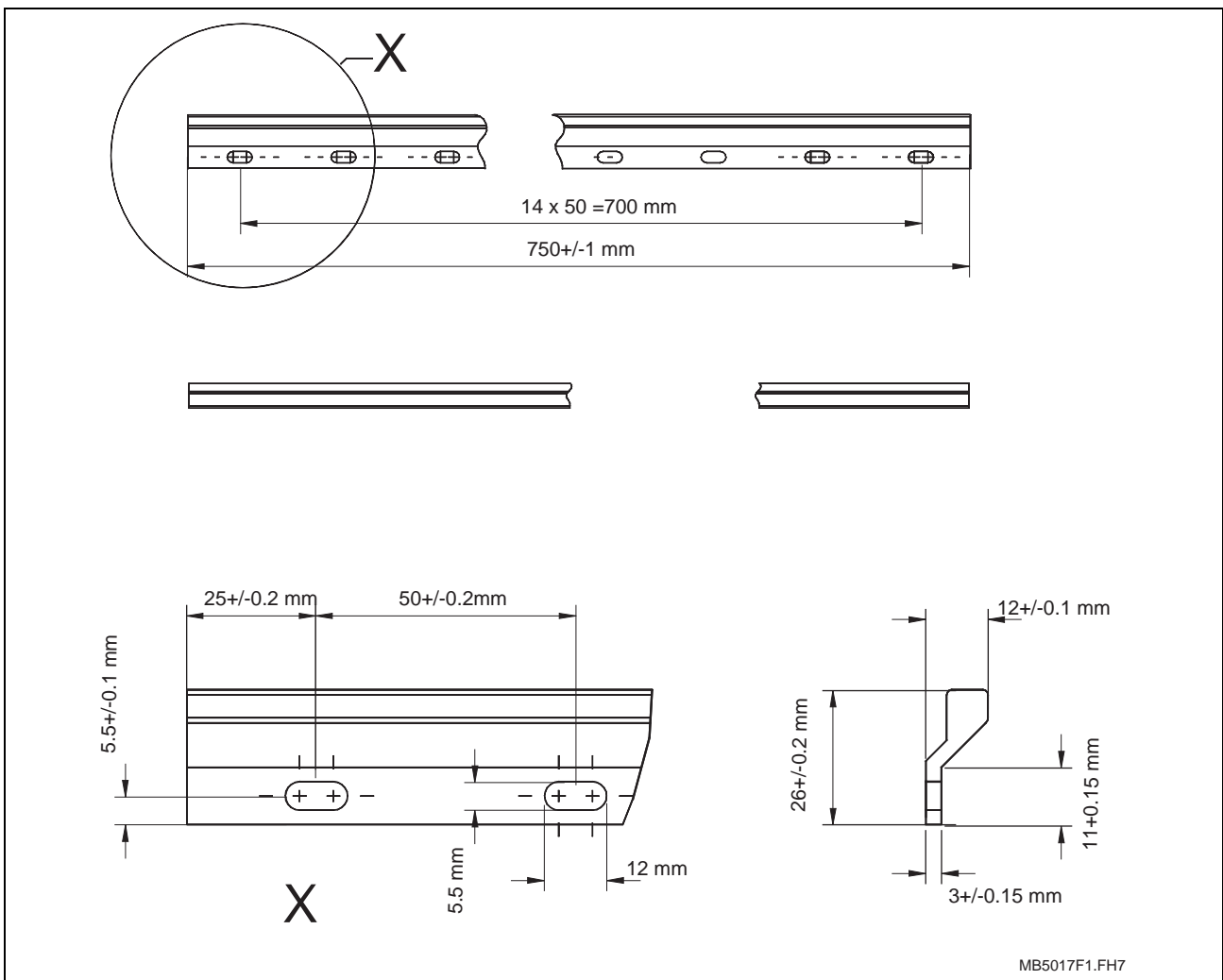

Fig. 3-4: Mounting rails

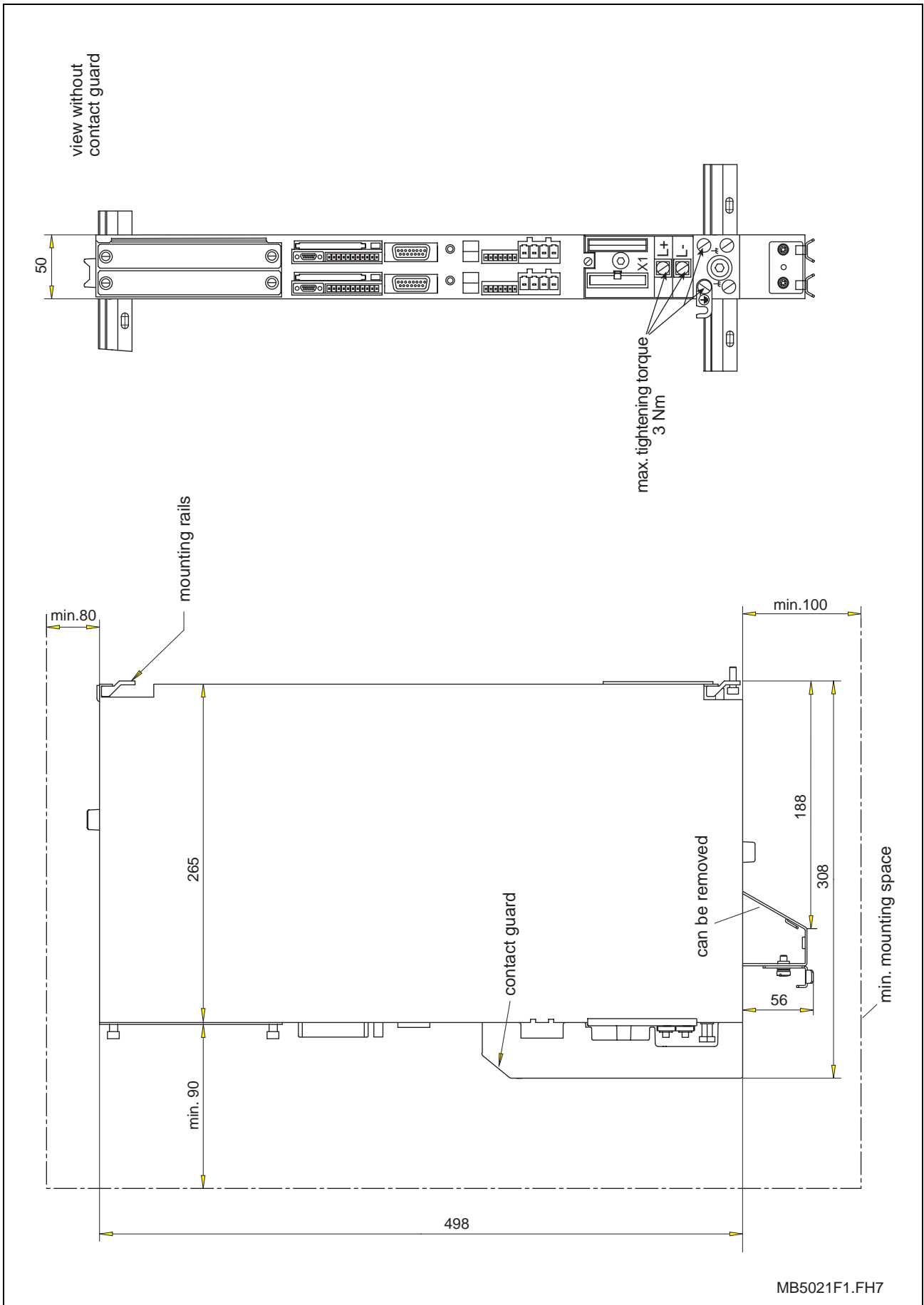

Fig. 3-5: Dimensional sheet - HDD02.1

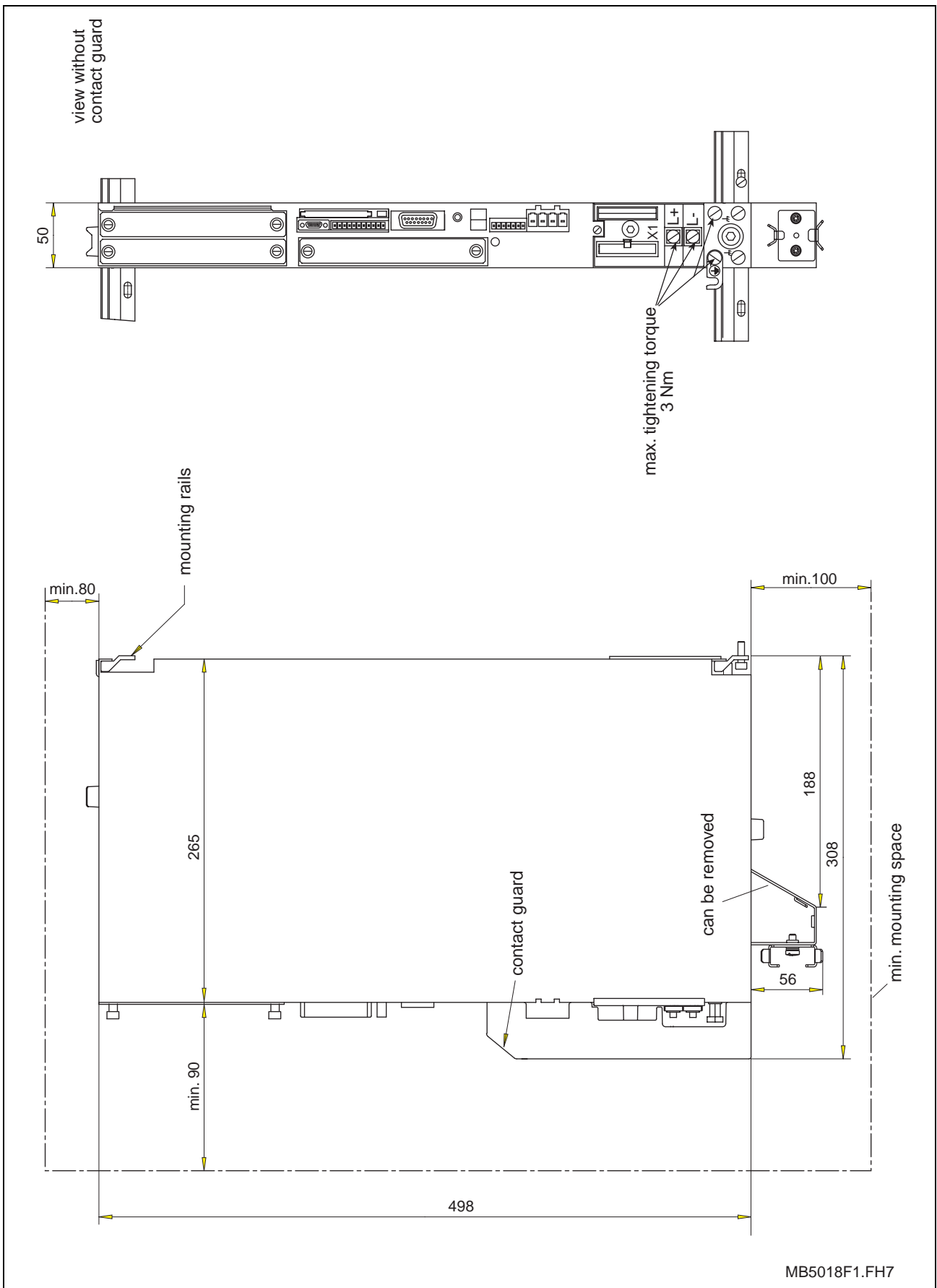

Fig. 3-6: Dimensional sheet - HDS02.1

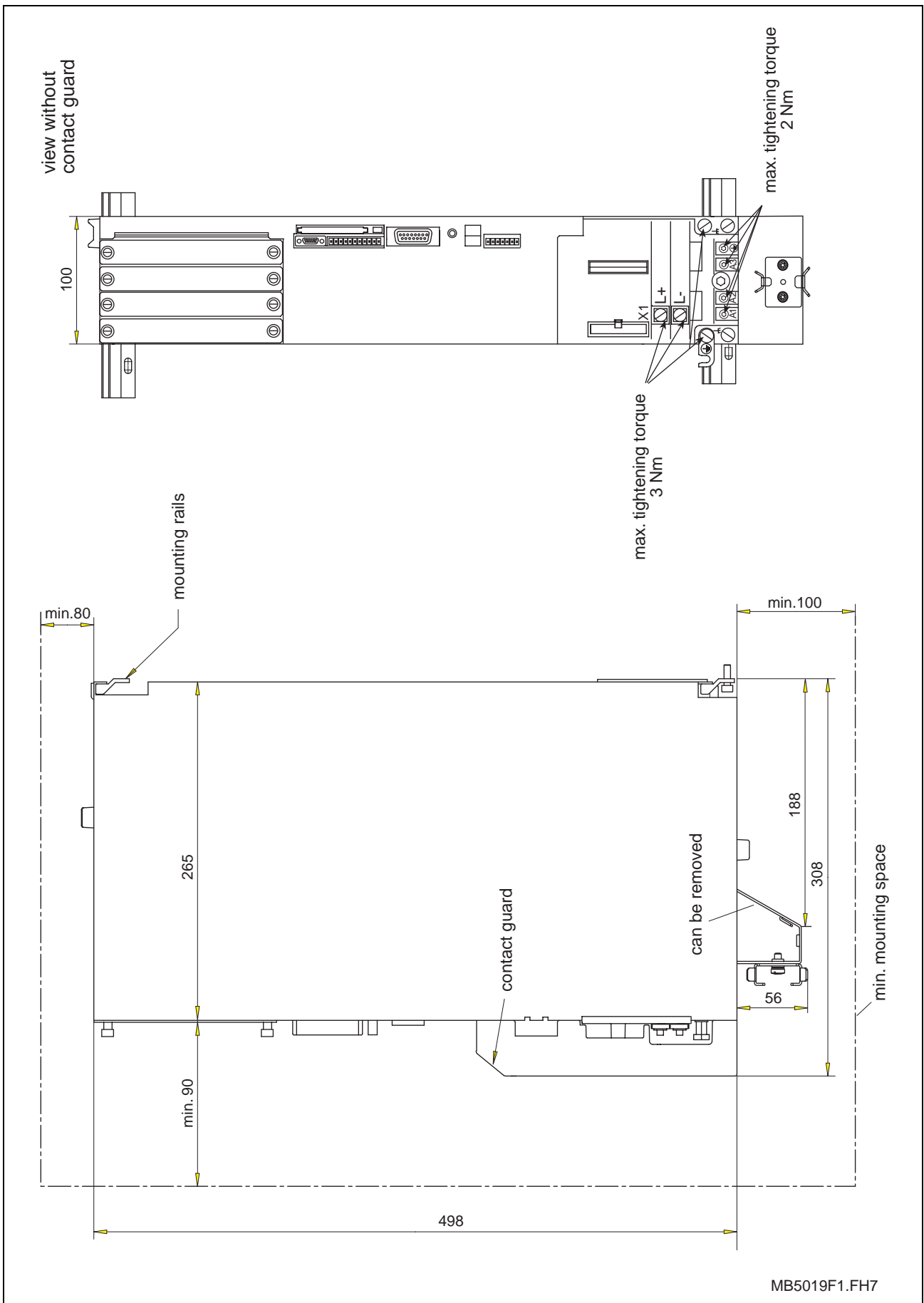

Fig. 3-7: Dimensional sheet - HDS03.1

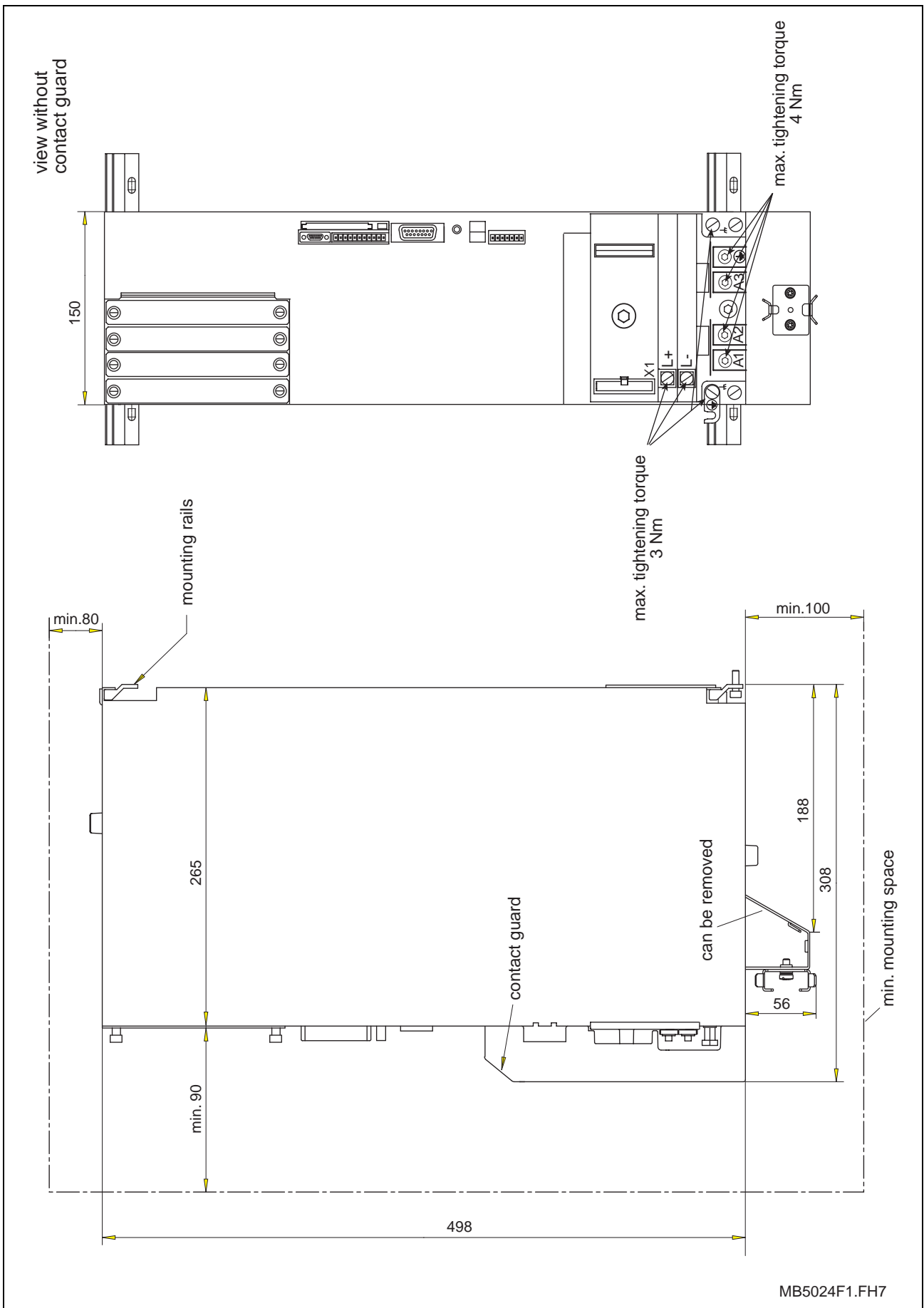

Fig. 3-8: Dimensional sheet - HDS04.1

3.4 Connection lines

- Supply line routing**
- A distance of at least 100 mm between power and control or signal cables (e.g., feedback cables) or
 - use a metal cable duct to isolate

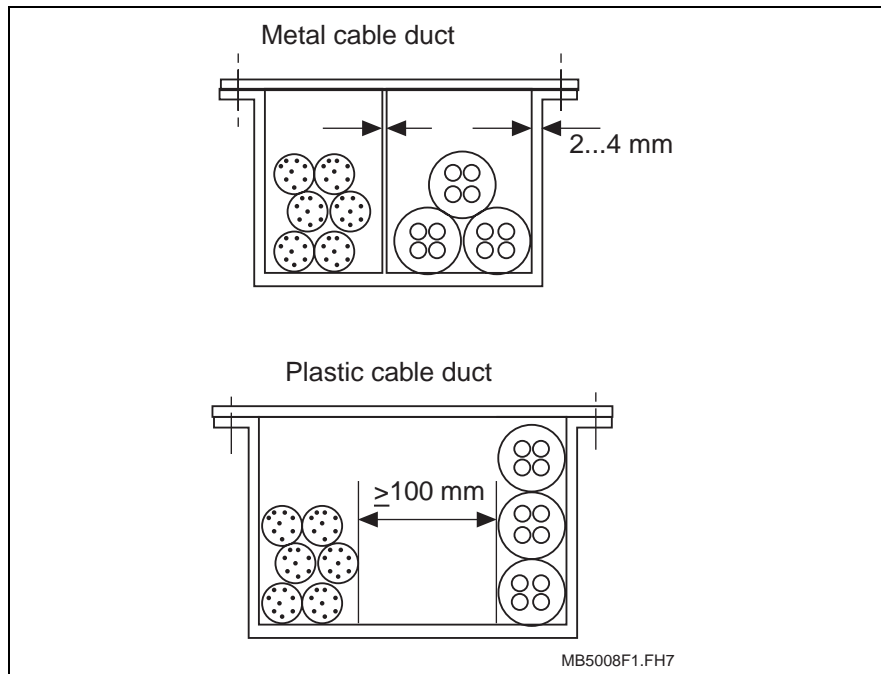

Fig. 3-9: Cable duct variants

- Do not route control or signal cables near high frequency units, magnetic fields (transformers, chokes, etc.) or high-voltage supply lines.
- Line lengths**
- Maximum motor cable length: 75 m
 - Maximum feedback connection length: 75 m



CAUTION

Errors when controlling motors and moving components

Mechanical injuries!

⇒ Clamping points or couplings reduce the maximum line length. Note the following!

The line lengths specified apply to:

- direct connections between drive controller and motor
- ready-made cables from INDRAMAT and
- an ambient temperature of $\leq 40^\circ \text{C}$ per EN 60 204

3.5 Measures against interference sources in the control cabinet

To maintain the limits of class B (rf interference level N) per DIN VDE 0470-1, ed. 11.92 and table 1 per DIN EN 55014, ed. 12.93 at the machine (in particular when operating within a residential and light industrial area), it applies:

- route motor power cable shielded or use a shielded motor power cable
- use shield attachment on controller
- use a suitable interference suppression filter in the mains supply line of the machine or plant and make sure it is properly mounted and operated

If inductive loads (e.g., chokes, contactors or relays) per contact or semiconductor are switched, then these loads must be interference suppressed:

- use freewheeling diodes with three-phase current actuation
- use a contactor type-related RC-interference suppression module with alternating current actuation
- interference suppression elements must be mounted at the inductance (e.g., contactor coil). The suppression effect could otherwise be considerably reduced.
- do not use varistors

If high-frequency equipment is to be used (e.g., components of oxidizing devices):

- locate and wire such equipment outside of the control cabinet (depending on local conditions, a separate control cabinet may be necessary).

Note: For details see the Project Planning Manual "Electromagnetic Compatibility (EMC) in AC drives", doc. type DOK-GENERL-EMV*****-PRJ*-EN-P

Only the machine manufacturer can check whether the limit values are being maintained or not.

4 Planning the electrical connections

4.1 General information

The electrostatic loads of persons and/or tools could damage either drive controllers or PCBs when discharging over such. Therefore, please note the following:



CAUTION

Error in controlling motors and moving components!

Electrostatic loads endanger electronic equipment and their operating safety!

⇒ Bodies coming into contact with components and PCBs must be discharged by grounding!

These bodies can be:

- the soldering iron used for soldering
- the human body (ground by touching a conductive, grounded object)
- parts and tools (placed on a conductive surface)

Endangered parts may only be stored or transported in conductive packaging.

Note: Indramat's terminal diagrams exclusively support the development of the machine terminal diagrams. When wiring the machine, use the terminal diagrams of the machine manufacturer!

- General notes**
- Route signal supply lines separate of load supply lines due to the interference.
 - Analog signals (e.g., command and actual values) must be fed via supply lines.
 - Mains, DC bus and power strands may not be connected with extra-low voltages or be permitted to come into contact with such.
 - During the conduction of a high voltage check or insulation check of the electrical equipment of the machine, release or remove all connections of the machine so avoid damaging the electronic components within the machine (permissible as per VDE 0113). INDRAMAT drive components are high-voltage and insulation checked as per VDE 0160.

4.2 Connecting the basic unit

Overview

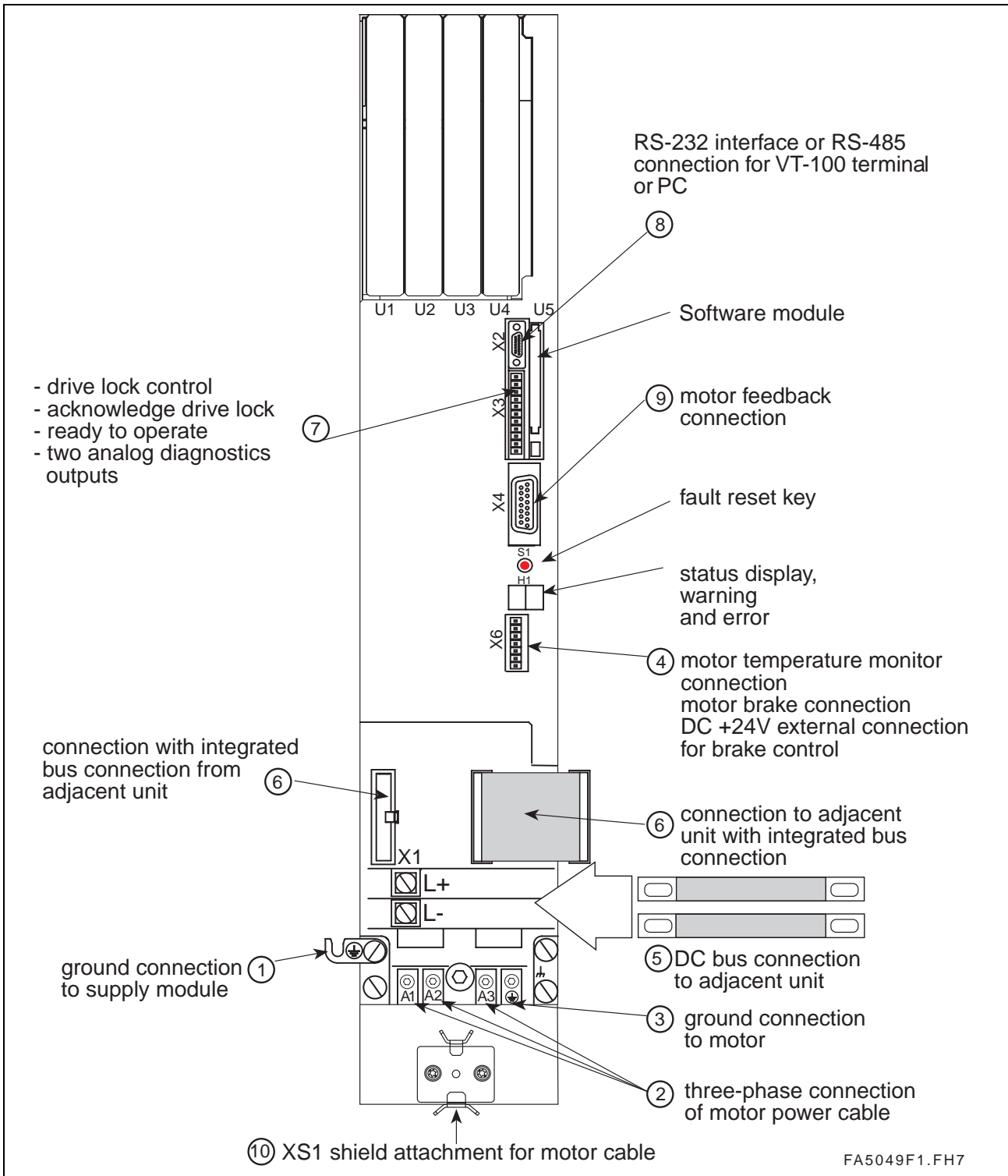

Fig. 4-1: Front view of the basic unit with connections labelled

For explanation on points ① ⑩ see the following pages.

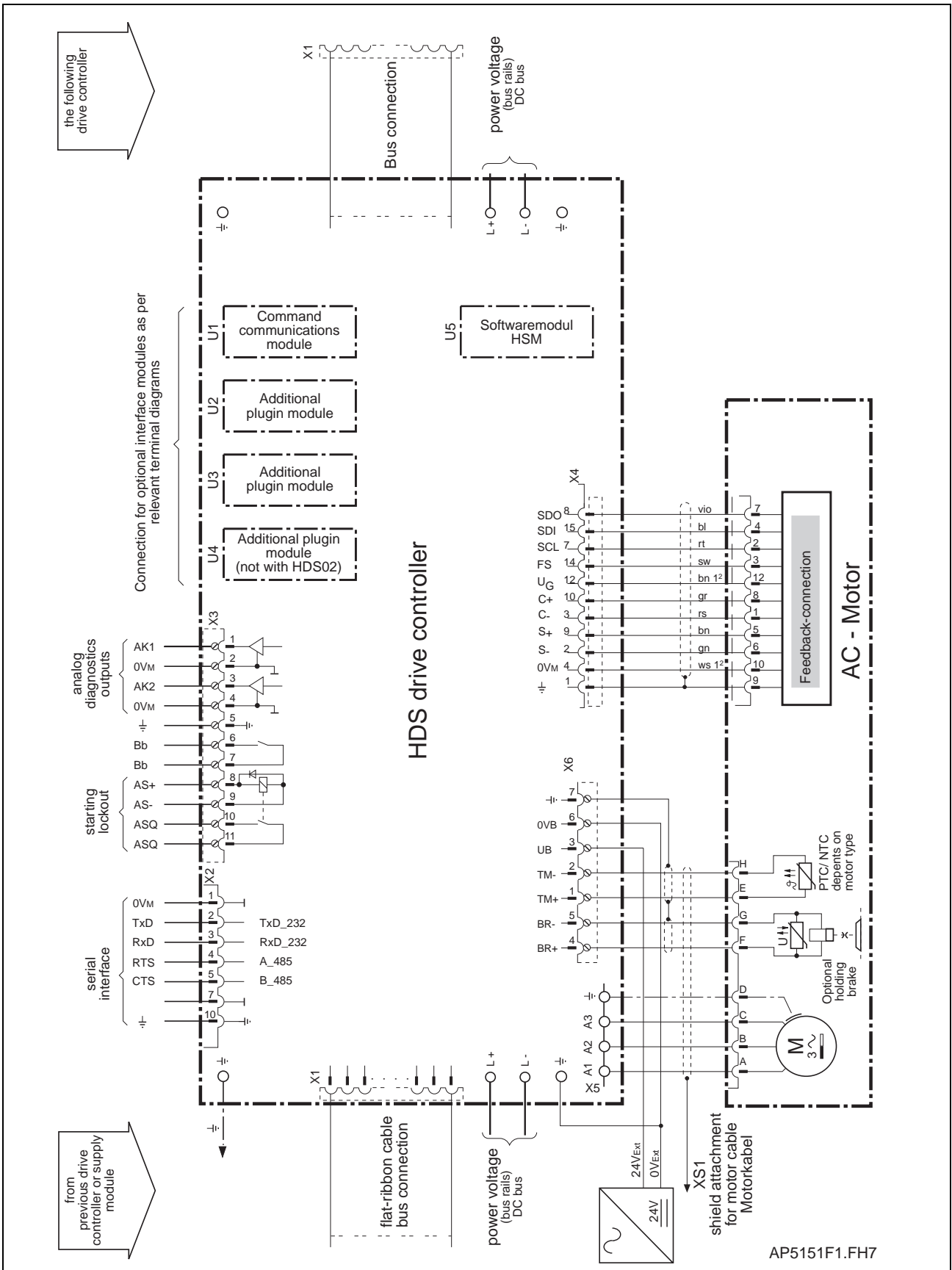

Fig. 4-2: Connections of a HDS drive controller labelled

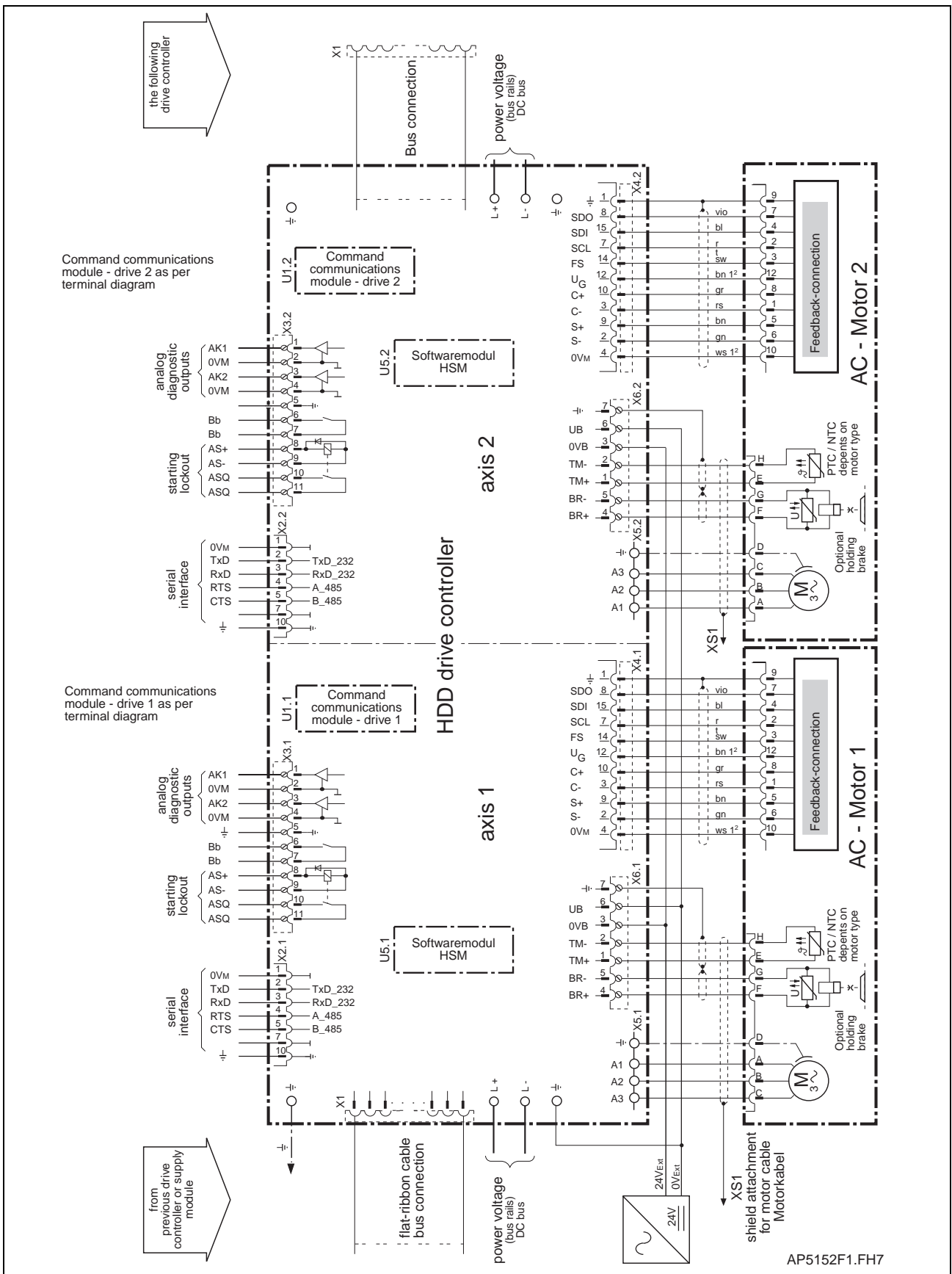

Fig. 4-3: Connections of a HDD drive controller labelled

① **Ground connections to the supply module**

HDD and HDS drive controllers are equipped with two ground connections (earthing) to the supply module:

- back wall of the unit and the mounting rails as well as
- the front of the grounding clip (see illustration)

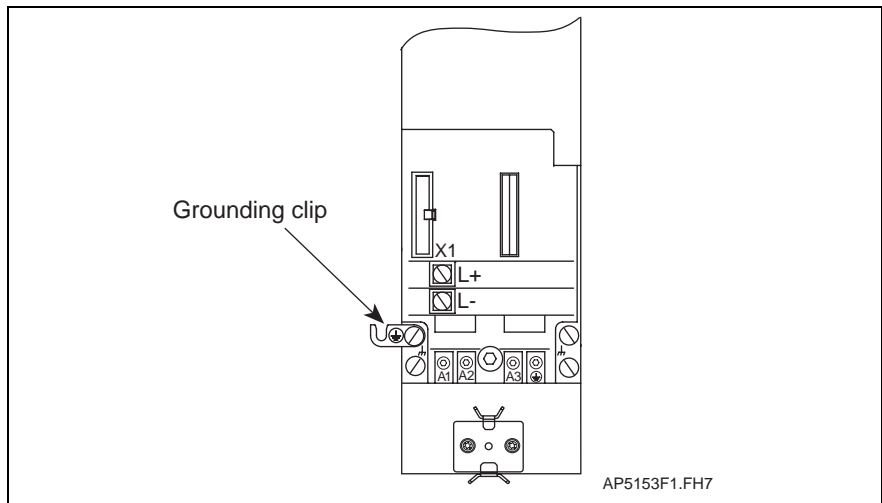

Fig. 4-4: Ground connections - controller

Also see section 8-1, "Mounting the drive controller" for supplementary information.

②+③+④ **Motor power cable connection**

INDRAMAT motor power cables should be used to connect drive controller and motor.

In an INDRAMAT motor power cable are:

- three supply lines for the motor power connection and
- a line for the grounded conductor connection
- a separately shielded pair of lines for the motor temperature monitor
- a separately shielded pair of lines for the motor holding brake
- and a complete shield mounted to shield attachment

The motor power cable is available as a ready-made cable from INDRAMAT. The cable can also be made of four twisted individual supply lines (3 phases, 1 grounded conductor) with a separately conducted, shielded supply line for temperature monitoring and the brake connection.

For supplementary technical data on connections and diameters, see the relevant motor description.

Line length

Maximum cable lengths equals 75 meters if INDRAMAT cables are used (see sec. 3.4).

④ Connector X6, Holding brake, for temperature monitor

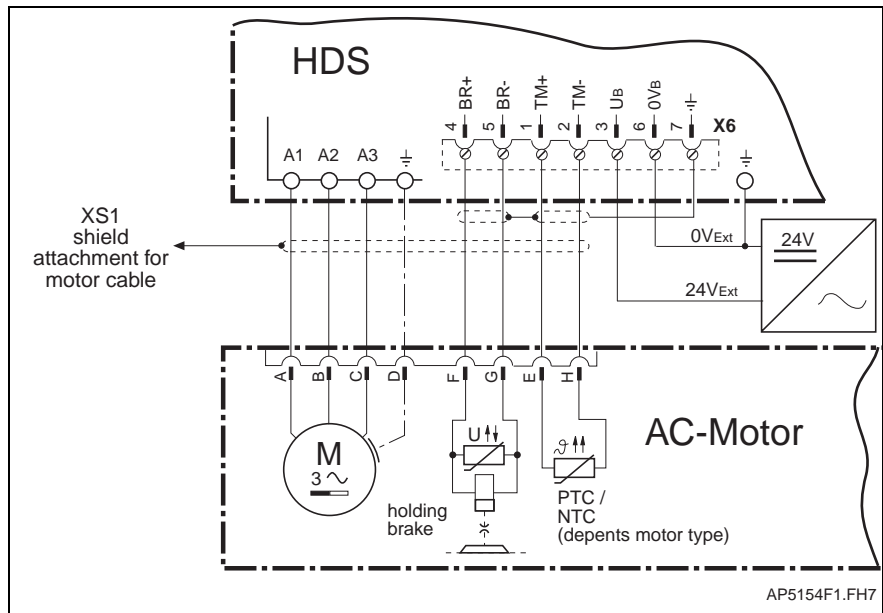

Fig. 4-5: Motor cable , holding brake and temperature monitor connection



If a motor holding brake is used, then it is necessary to connect an external 24V three-phase voltage source. The 0Vext (= 0V_B) must be galvanically connected with the reference potential or housing of the drive controllers!

Current consumption of the holding brake is listed in the Project Planning Manual of AC motors.

The AC motor holding brake is not a working brake. It wears down after about 20,000 motor revolutions against the closed brake disc.

Note: To release a holding brake in the MHD/MKD servo motors, apply the DC +24V +/- 10 % directly to the motor. The voltage to release the brake is applied to X6/3 (+24V) and X6/6 (0V). It must be ensured that the brake will release even if longer motor power cables are used (voltage drop with long motor power cables can be compensated by increasing supply voltage (up to DC +26.5V) and/or with a regulated voltage supply at X6/3 and X6/6.

Control of the motor holding brake

The drive controller controls the holding brake.

⑤ DC bus voltage connection

Adjacent drive controllers are generally connected via the connection wires (shipped with the drive).

If a connection with the connection wires should not be possible, then establish the connection using twisted supply lines that are as short as possible (maximum length equals one meter, minimum diameter 16mm²).

⑥ Connector X1, bus connection

The control electronics of the drive controller receive their power via connector X1. The connection starts at the supply unit and runs to the drive controller with the help of the flat-ribbon cable integrated into the units. Maximum length here also equals one meter (if extensions are used)!

⑦ Connector X3, Analog outputs, Ready to operate, Starting lockout

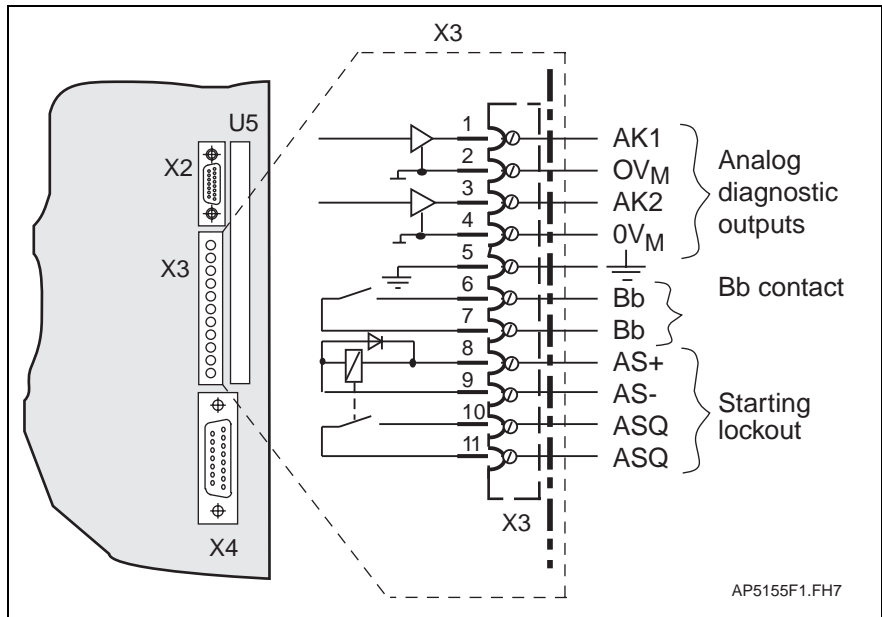

Fig. 4-6: Connector assignment - X3

Analog diagnostic outputs, AK1 AK2

Analog diagnostic outputs are outputs over which drive-internal variables can be generated for test purposes (e.g., with startups). For detailed information on analog diagnostic outputs, see documentation "DIAX04 Function Description".

Current load capacity: 4 mA

Output voltage: DC +/-10 V

Ready to operate contact Bb

Once the ready to operate contact "Bb" closes, then the drive controller is ready to receive power.

Contact "Bb" closes once power voltage is on and all monitoring functions have signalled they are operational.

Contact "Bb" can be used, e.g., to evaluate the controls so that it can recognize, in the event a unit, in hardware terms, is defective, which drive controller in the drive package has failed.

Circuit load: DC 24 V, 1 A (maximum = duration)

Minimum load of contact: 10 mA

Note: The direct connection of a mains contactor via contact Bb is only permissible if the ON current does not exceed 1A. Higher currents can cause the relay to fail. The use of varistors as protective circuits is not recommended as these age. This can, in turn, cause an early failure of the connected components and thus the unit itself as well.

Starting lockout AS+, AS-, ASQ, ASQ

The starting lockout is a safety mechanism to secure against unintentional startups of the connected motor in the event an error occurs. It serves to securely switch off separate working areas within a machine or plant.

Note: A starting lockout does not bring moving drives to a standstill.

Supplementary information on starting lockouts is outlined in the description "Starting lockout function in DDS drive controllers" DOK-DIAX02-DDS*ANL*FKT-ANW1-EN-P.

AS+, AS-:

- control inputs for relay coils
- voltage: DC 20 30 V
- power: 1.5 W

ASQ, ASQ:

Potential-free feedback contact which acknowledges the actuating of the starting lockout to an external control.

Breaking capacity: DC 24 V, 1 A (maximum = duration)

The actuation of the relay of the starting lockout in the drive controller is confirmed by the closing of the potential-free feedback contact (output ASQ - ASQ) to the external control.

To activate the starting lockout, apply a voltage of DC *20 to 30 volts between AS+, AS-.

⑧ Connector X2, Serial interface

This serial interface supports the parametrization of the controller with a PC with the help of suitable software (e.g., SERC-TOP or DRIVE-TOP).

It can be operated as RS-232 or, from device index A07 onwards, as RS-485.

The RS-232 interface

The RS-232 interface enables:

- a maximum number of participants of 1
- a transmission length of up to 15 meters
- transmission rates of 9600/19200 baud

When using DriveTop, only one drive can be parametrized via the RS-232 interface.

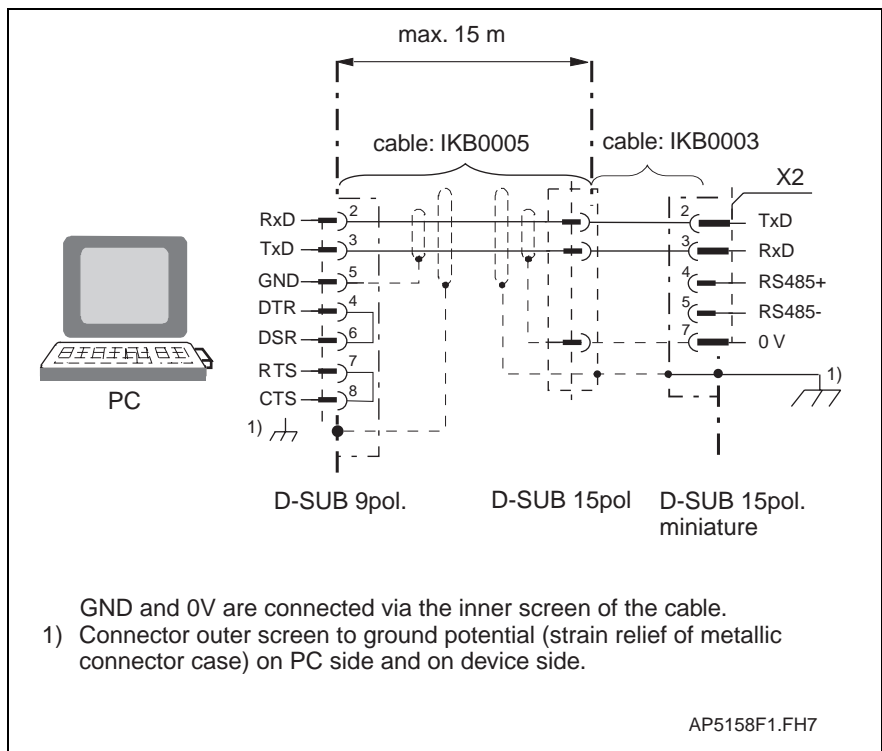

Fig. 4-7: Connecting a PC using the RS-232 interface

RS-485 Interface

The RS-485 interface enables:

- the implementation of a serial bus with up to 31 participants connected via a two-wire line (half duplex mode).
- a transmission length of up to 500 meters
- transmission rates of 9600/19200 baud
- the implementation of central PC-supported visualization unit

The RS-485 can be used to start up several DKCs with DriveTop without having to plug into a different socket of of the interface cable.

The following solutions for operations with RS-485 are:

- RS-232/RS-485 converter between PC and drives
- RS-485 plug-in cards in PC

Please contact your PC supplier to find the solution for your application.

Installation guidelines for interface lines

Note: Details are outlined in the Project Planning Manual "Electromagnetic compatibility (EMC) of drives and control systems",
Doc. type DOK-GENERL-EMV*****-PRJ-EN-P*

Connector for RS-485 interface

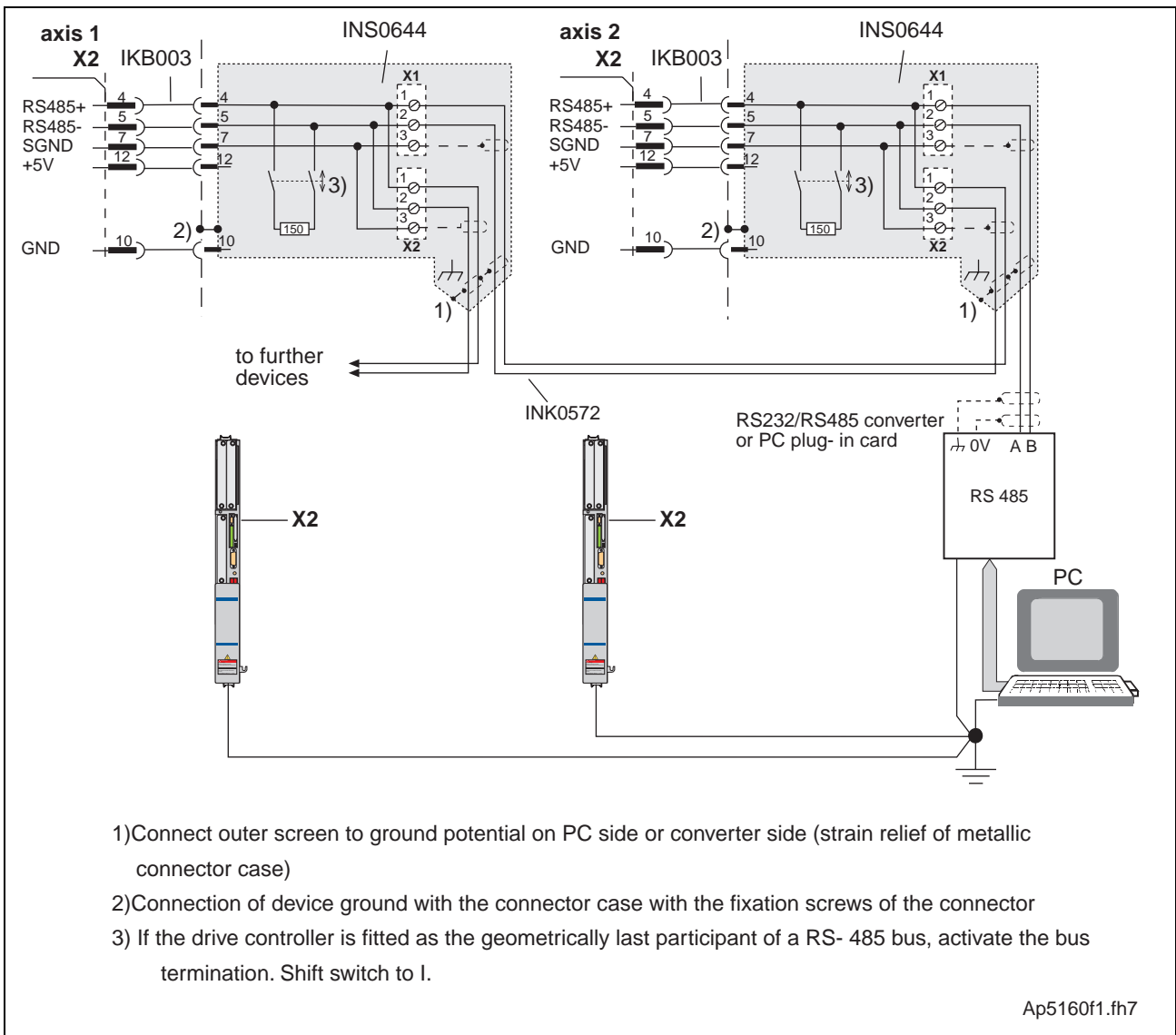

Fig. 4-8: Example on how to connect an RS-485

⑨ Connector X4, Motor feedback

An HSF or RSF INDRAMAT motor feedback is connected at X4 in compliance with the terminal diagram of the motor implemented. If any other type of motor encoder is connected, then it is necessary to use an appropriate additional plugin module.

The same guidelines as apply to the power cable (see section 4) also apply to the connection between drive controller and motor feedback.

⑩ Connector XS1, Shield bracket of motor cable

The entire shield of the motor cable is mounted to shield bracket XS1 using the enclosed clamp fitting. It is matched to the diameter of the cable by simply selecting the relevant clamp base on the mounting panel. The cable output direction can be either horizontal or vertical and is achieved by adjusting the mounting panel.

Notes

5 Accessories

5.1 LWLs (Fiber optic cables)

Controllers with SERCOS interface are connected via LWLs to the superordinate controls.

The LWLs (cable, connector and/or ready-made LWL) must be ordered separately.

Supplementary information about "LWLs" is outlined in the document "LWL Handling" (doc. no.: 209-0090-4101-xx).

This document discusses the following points:

- LWLs in general
- basic plans for optical transmission systems
- routing instructions for LWLs
- dampening measurements of ready-made LWLs
- available LWL-FSMA plugin connectors and LWLs
- instructions on making an FSMA connector
- tools for making LWLs

Use the illustration below to determine the order information for the LWLs in the entire system.

Selecting LWL connections

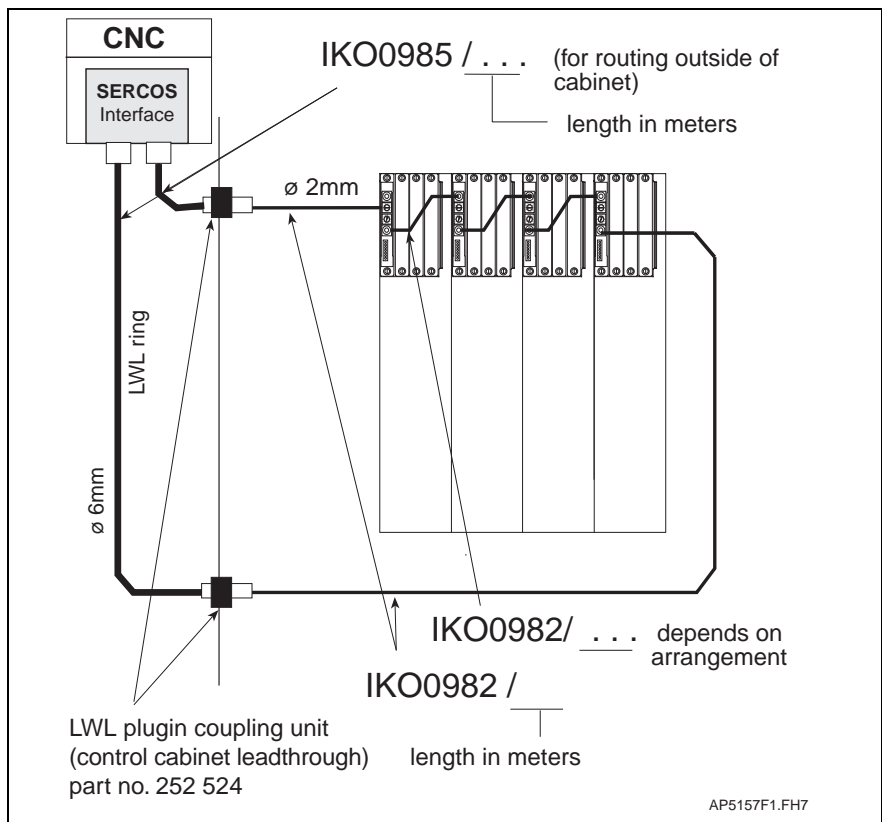

Fig. 5-1: Selecting ready-made LWLs

Notes

6 Transport and Storage

6.1 General instructions

- Transportation**
- Use suitable transportation equipment.
 - Use shock-absorbant supports if excessive shocks and vibrations could occur during transport.
 - Electrostatically endangered components (e.g., plugin modules) may only be transported in conductive packaging.
- Storage**
- Permissible temperature range for storage and transport: -30° C to +85° C
 - Store dry, dust and shock free.
 - Electrostatically endangered components (e.g., plugin modules) may only be stored in conductive packaging.

Notes

7 Identifying the Merchandise

7.1 Delivery slip and barcode sticker

The delivery slip lists the merchandise of the entire delivery by name and order designation.

On the packaging of the controller itself there are barcode stickers which identifies it.



Fig. 7-1: Barcode sticker on the packaging of a HDD / HDS (Example)

7.2 Type plate of the drive controller

- Position of the type plate** The controller is clearly identified by two type plates (see Fig. 7-2) :
- type plate of the basic unit (on the top of the unit)
 - type plate of the complete configuration (on the inserted card, next to the plugin modules)

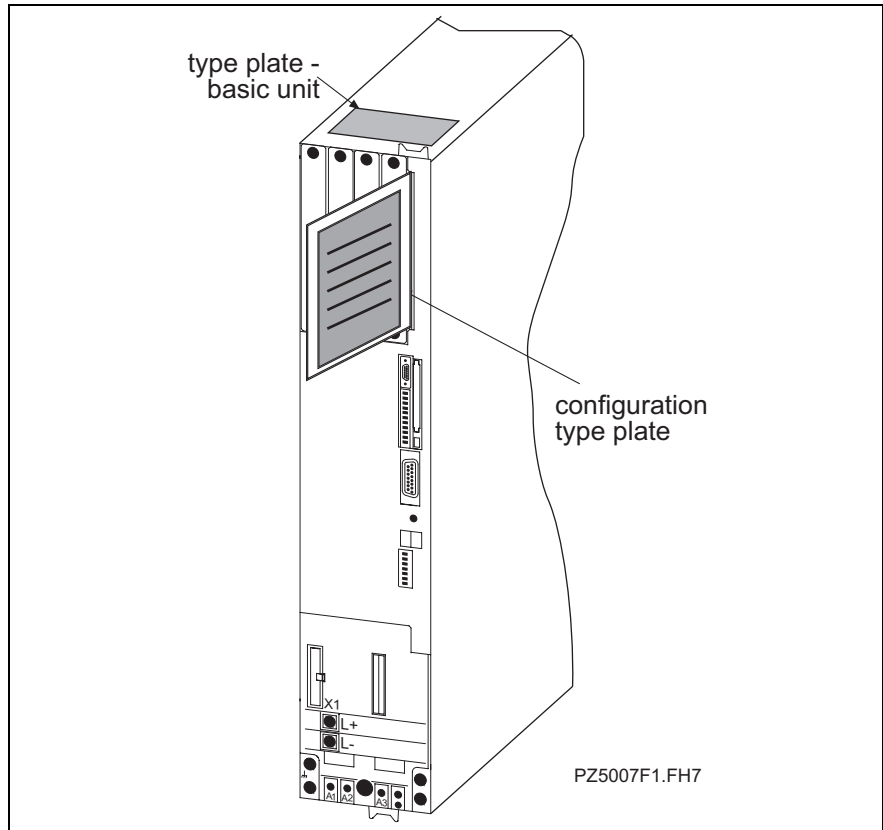

Fig. 7-2: Position of the type plates

7.3 Other type plates

- Firmware type plate** The firmware type plate offers information on the type of firmware used (= drive operating software). Like the configuration type plate, it is on the inserted card, next to the plugin modules.

- Ready-made cables** The order number and the length of the cable are on the cable label (cable marker).

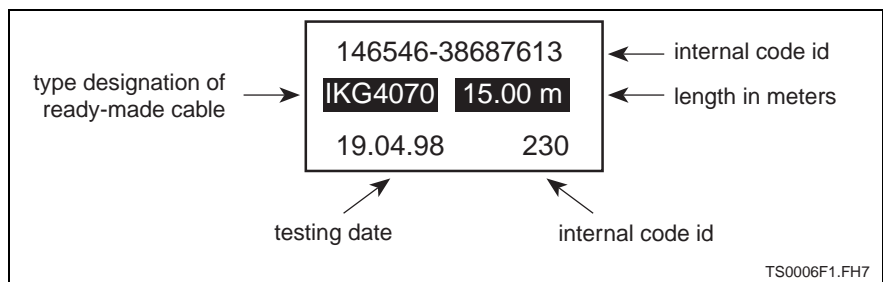

Fig. 7-3: Example: ready-made cable label

- Cable parts** Order designations for cable parts are printed on the cables.

8 Mounting and installation

8.1 Mounting the drive controller

Note: Please note permissible mounting conditions (see pg. 3.1)

Arranging the controller

Arrange the drives with higher power needs and high currents as close to the supply unit as possible.

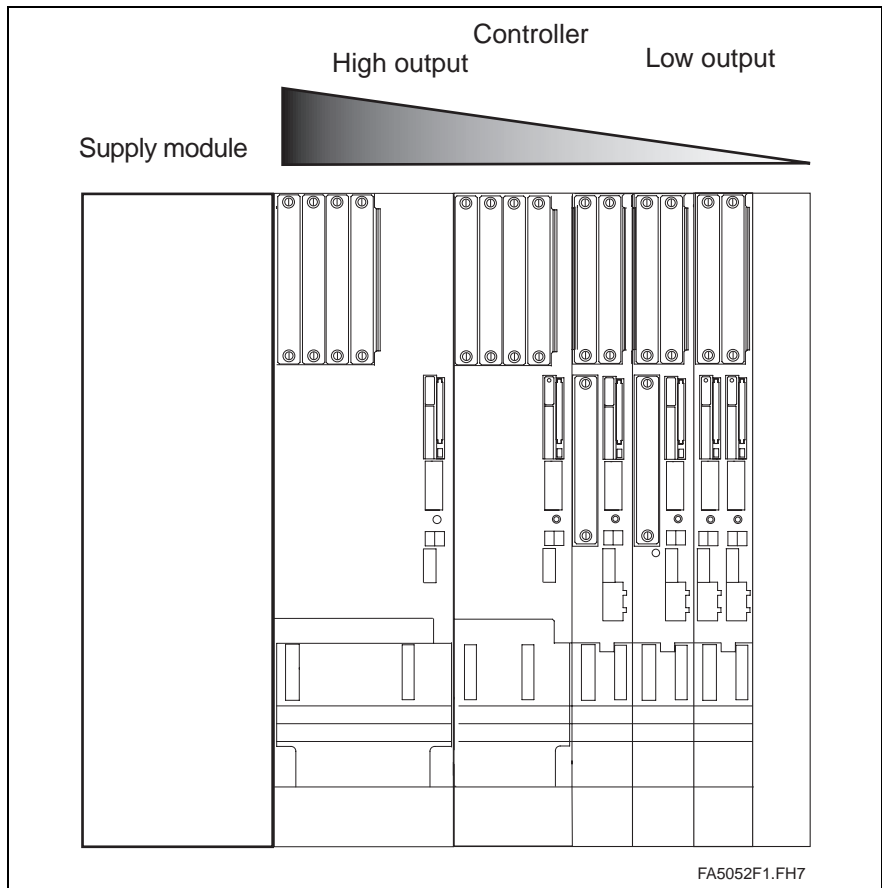

Fig. 8-1: Preferred arrangement of units in the control cabinet

Fastening the mounting rails

Mounting rails support the entire drive package. To be able to take up the corresponding forces it is necessary to fasten the rails in at least every second slot using an M5 screw.

As the mounting rails also conduct the potential compensation of the drives, there must be good contact of the mounting rails and the mounting panel. Therefore, it may be necessary to remove any paints or finishes on the mounting panel within the area of mounting!

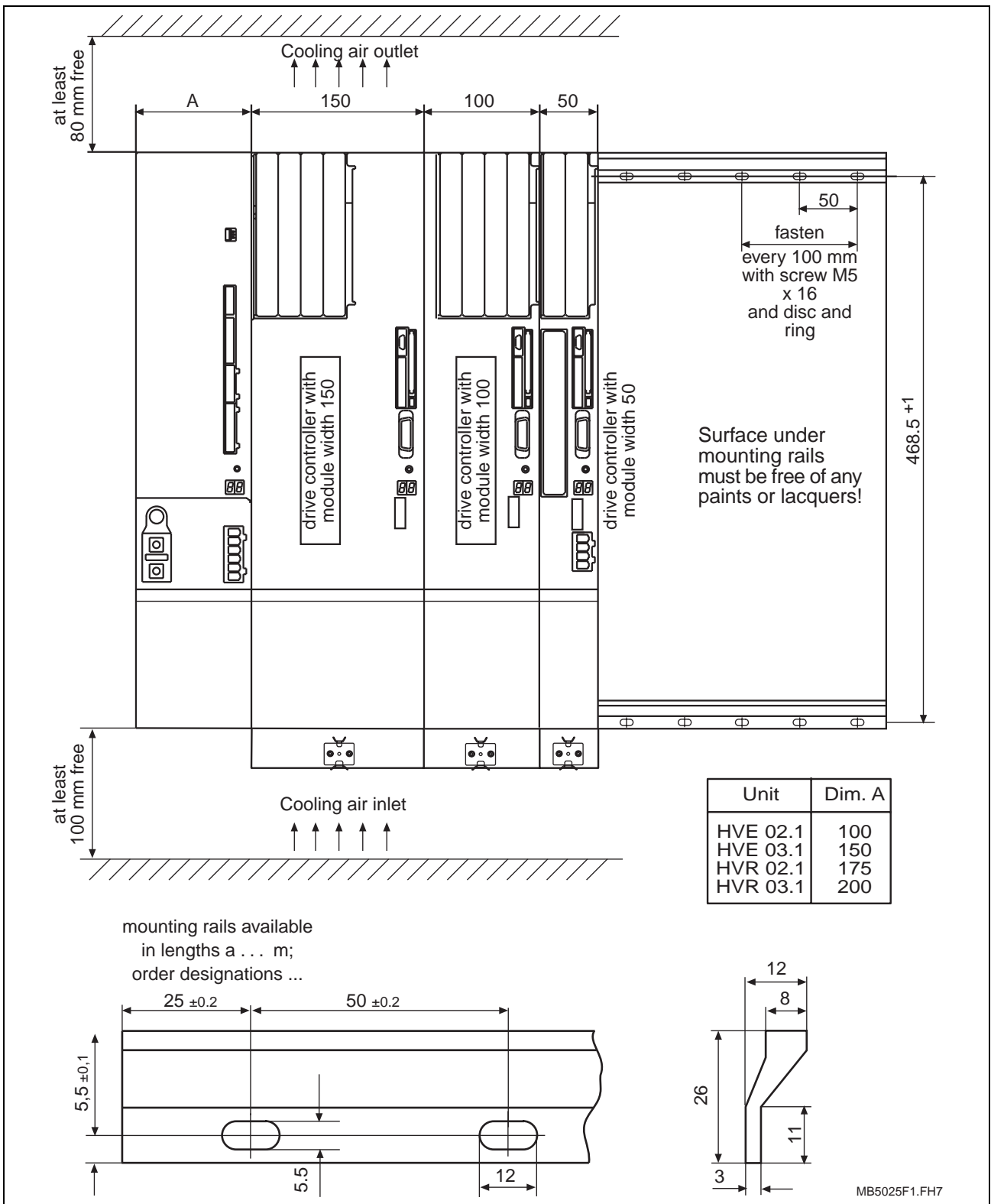

Fig. 8-2: Mounting and fastening the mounting rails

Mounting the drive controllers

1. Hand the drive controller onto the mounting rails.
2. Push drive controller to the adjacent unit.
3. Tighten clamping screw (see Fig. 8-3).

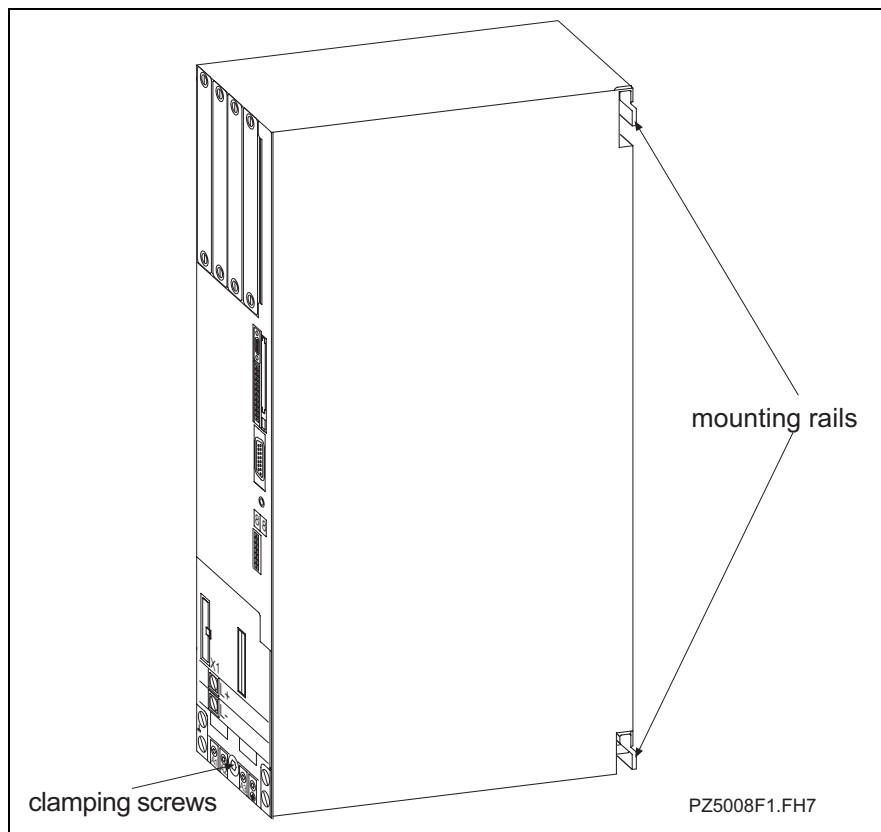

Fig. 8-3: Mounting the drive controller

8.2 Installation

- Establish ground connection with a grounding clip on the lower edge of the drive controller.
- DC bus connection for the power connections must be released on the underside of the unit and power connection to adjacent unit or supply unit must be established.
- Close bus connection to adjacent unit using the integrated flat-ribbon cable.
- Connect motor power cable with protective conductor and shield.
- Connect motor temperature sensor and holding brake (optional).
- Connect motor feedback.

Notes

9 Service and Testing

9.1 Error diagnoses

	The controller generates drive error messages via <ul style="list-style-type: none"> • the SERCOS interface and • the status display H1 on the front of the unit
Diagnostic notes in the documentation	In all controllers of the DIAX04 line, the meaning of the error messages and notes on fault clearance are identical. In the event of questions, just check the relevant function description.
Diagnostics via the Hotline	If a problem cannot be dealt with by the user, then please feel free to contact our INDRAMAT customer service office of your location. See also Supplement: Customer Service Locations - Sales & Service Facilities
Phone number	INDRAMAT's customer service can be reached at the following telephone numbers during the hours indicated: INDRAMAT's customer service can be reached from Mondays to Fridays from 7.00 a.m. to 5 p.m. at the following phone number: 09352 / 40 - 4894 and 09352 / 40 - 4922
Service-Hotline	The Service-Hotline can be reached at 0172 / 66 00 406 or 0171 / 333 8826 during the following hours:

Monday to Friday:	5.00 to 11.00 pm CET
Saturday:	8.00 am to 8.00 pm CET
Sundays and holidays:	9.00 am to 7.00 pm CET

Fig. 9-1: INDRAMAT hotline hours

To ensure a quick elimination of problems and errors, we would request you to make a note of the following prior to calling INDRAMAT customer service office, viz.,

- type data of the relevant controller, motor and gears
- the status
- any problem or diagnostics displays
- the software status.

9.2 Repairs and replacements

Repairs	If the drive needs to be repaired, then: <ul style="list-style-type: none"> • repairs may only be conducted by INDRAMAT customer service or appropriately trained personnel.
Unit or component replacement	Unit and component replacement for all DIAX04 units is outlined in the document "DIAX04 - Notes on fault clearance". After a unit is replaced, it is necessary to conduct a restart.

9.3 High voltage check and insulation check

INDRAMAT drive components are tested as per DIN VDE 0160 for high-voltage and insulation.

10 Index

A

Accessories	5-1
Additional plugin module	2-2
AK1	4-7
AK2	4-7
Ambient conditions	3-1
Ambient temperature	3-1
Analog diagnostic outputs	4-7
Analog outputs	4-7
Arrangement of cooler	3-2
Arranging the controller	8-1
ASQ	4-8

B

Barcode sticker	7-1
Basic unit	2-1, 2-2
Bb	4-7
Bus connection	4-7

C

Cable duct	3-9
Command communication module	2-2
Complete shield	4-5
Component replacement	9-1
Condensation	3-3
Configuration	2-1
Configuration type plate	2-4
Connection labelling	4-2, 4-3, 4-4
Connector for RS485 - interface	4-11
Connector X1	4-7
Connector X2	4-9
Connector X3	4-7
Connector X4	4-11
Control	2-3
Coolers	3-2

D

DC bus voltage	4-6
Delivery slip	7-1
Diagnostic notes	9-1
Diagnostics	9-1
DIAX04	1-1
Digital I/O cards	2-2
Dimensional sheet HDD02.1	3-5
Dimensional sheet HDS02.1	3-6
Dimensional sheet HDS03.1	3-7
Dimensional sheet HDS04.1	3-8
Dimensional sheets	3-4
Drive controller HDD	2-2

E

Error diagnoses	9-1
External voltage tests	9-2

F

Firmware	2-2
Firmware type plate	7-2

G

Ground connections	4-5
Grounded conductor connection	4-5
Grounding clip	4-5

H

Holding brake	4-6
Holding brake control	4-6
Hotline	9-1

I

Individual components	1-2
Installation	8-1, 8-3
Installation elevation	3-1
Installation guidelines for RS485 - lines	4-10
Interface card	2-3
Interfacekarten	2-3
Interference sources	3-10

L

Line lengths	3-9, 4-5
LWLs (Fiber optic cables)	5-1

M

Measuring system	2-3
Motor cable	4-6
Motor feedback	4-11
Motor holding brake	4-5
Motor temperature monitor	4-5
Motor power cable	4-5
Mounting	8-1
Mounting rails	3-4, 8-1
Mounting the drive controllers	8-3

O

Operating software	2-2
--------------------	-----

P

Packaging	7-1
Phone number	9-1
Plugin modules	2-1

Position of the type plate 7-2
Protection category 3-2

R

Rated data 3-1
Ready to operate 4-7
Ready to operate contact 4-7
Ready-made cables 7-2
Repairs 9-1
Replacements 9-1
RS 485 Interface 4-10

S

SERCOS interface 2-2
Serial bus 4-10
Serial interface 4-9
Service 9-1
Software module 2-2
Starting lockout 4-7
Starting lockout AS 4-8
Sticker 7-1
Storage 6-1
Supply line routing 3-9
Supply lines 3-9
Supply module 1-2

T

Technical data 2-7
Temperature monitor 4-6
Testing 9-1
Transportation 6-1
Type codes HDS 2-6
Type plate 7-2

U

Unit type plates 7-2

Notes

Kundenbetreuungsstellen - Sales & Service Facilities

Deutschland - Germany

Vertriebsgebiet Mitte Germany Centre <input checked="" type="checkbox"/> V/S <input checked="" type="checkbox"/> Service	Vertriebsgebiet Ost Germany East <input checked="" type="checkbox"/> V/S <input checked="" type="checkbox"/> Service	Vertriebsgebiet West Germany West <input checked="" type="checkbox"/> V/S <input checked="" type="checkbox"/> Service	Vertriebsgebiet Nord Germany North <input checked="" type="checkbox"/> V/S <input type="checkbox"/> Service
INDRAMAT GmbH Bgm.-Dr.-Nebel-Str. 2 D - 97816 Lohr am Main Telefon: +49 (0)9352/40-0 Telefax: +49 (0)9352/40-4885	INDRAMAT GmbH Beckerstraße 31 D - 09120 Chemnitz Telefon: +49 (0)371/35 55-0 Telefax: +49 (0)371/35 55-333	INDRAMAT GmbH Harkortstraße 25 D - 40849 Ratingen Telefon: +49 (0)2102/43 18-0 Telefax: +49 (0)2102/41 315	INDRAMAT GmbH Kieler Straße 212 D - 22525 Hamburg Telefon: +49 (0)40/85 31 57-0 Telefax: +49 (0)40/85 31 57-15
Vertriebsgebiet Süd Germany South <input checked="" type="checkbox"/> V/S <input type="checkbox"/> Service	Gebiet Südwest Germany South-West <input checked="" type="checkbox"/> V/S <input checked="" type="checkbox"/> Service		INDRAMAT Service-Hotline INDRAMAT GmbH Telefon: +49 (0)172/660 04 06 oder Telefon: +49 (0)171/333 88 26
INDRAMAT GmbH Ridlerstraße 75 D-80339 München Telefon: +49 (0)89/540138-30 Telefax: +49 (0)89/540138-10	INDRAMAT GmbH Böblinger Straße 25 D-71229 Leonberg Telefon: +49 (0)7152/9 72-6 Telefax: +49 (0)7152/9 72-727		

Kundenbetreuungsstellen in Deutschland - Service agencies in Germany

Europa - Europe

<p>Austria <input checked="" type="checkbox"/> V/S <input type="checkbox"/> Service</p> <p>Mannesmann Rexroth Ges.m.b.H. Geschäftsbereich INDRAMAT Hägelingasse 3 A - 1140 Wien</p> <p>Telefon: +43 (0)1/9852540-400 Telefax: +43 (0)1/9852540-93</p>	<p>Austria <input type="checkbox"/> V/S <input checked="" type="checkbox"/> Service</p> <p>Mannesmann Rexroth G.m.b.H. Geschäftsbereich INDRAMAT Industriepark 18 A - 4061 Pasching</p> <p>Telefon: +43 (0)7221/605-0 Telefax: +43 (0)7221/605-21</p>	<p>Belgium <input checked="" type="checkbox"/> V/S <input checked="" type="checkbox"/> Service</p> <p>Mannesmann Rexroth N.V.-S.A. Geschäftsbereich INDRAMAT Industrielaan 8 B-1740 Ternat</p> <p>Telefon: +32 (0)2/5823180 Telefax: +32 (0)2/5824310</p>	<p>Denmark <input checked="" type="checkbox"/> V/S <input checked="" type="checkbox"/> Service</p> <p>BEC AS Zinkvej 6 DK-8900 Randers</p> <p>Telefon: +45 (0)87/11 90 60 Telefax: +45 (0)87/11 90 61</p>
<p>England <input checked="" type="checkbox"/> V/S <input checked="" type="checkbox"/> Service</p> <p>Mannesmann Rexroth Ltd. INDRAMAT Division 4 Esland Place, Love Lane GB - Cirencester, Glos GL7 1YG</p> <p>Telefon: +44 (0)1285/658671 Telefax: +44 (0)1285/654991</p>	<p>Finland <input checked="" type="checkbox"/> V/S <input type="checkbox"/> Service</p> <p>Rexroth Mecman OY Ansatie 6 SF-017 40 Vantaa</p> <p>Telefon: +358 (0)9/84 91 11 Telefax: +358 (0)9/84 91 13 60</p>	<p>France <input checked="" type="checkbox"/> V/S <input checked="" type="checkbox"/> Service</p> <p>Mannesmann Rexroth S.A. Division INDRAMAT Parc des Barbanniers 4, Place du Village F-92632 Gennevilliers Cedex</p> <p>Telefon: +33 (0)141 47 54 30 Telefax: +33 (0)147 94 69 41 Hotline: +33 (0)6 08 33 43 28</p>	<p>France <input checked="" type="checkbox"/> V/S <input type="checkbox"/> Service</p> <p>Mannesmann Rexroth S.A. Division INDRAMAT 270, Avenue de Lardenne F - 31100 Toulouse</p> <p>Telefon: +33 (0)5 61 49 95 19 Telefax: +33 (0)5 61 31 00 41</p>
<p>France <input checked="" type="checkbox"/> V/S <input type="checkbox"/> Service</p> <p>Mannesmann Rexroth S.A. Division INDRAMAT 91, Bd. Irène Joliot-Curie F - 69634 Vénissieux Cedex</p> <p>Telefon: +33 (0)4 78 78 53 65 Telefax: +33 (0)4 78 78 52 53</p>	<p>Italy <input checked="" type="checkbox"/> V/S <input checked="" type="checkbox"/> Service</p> <p>Mannesmann Rexroth S.p.A. Divisione INDRAMAT Via G. Di Vittoria, 1 I - 20063 Cernusco S/N.MI</p> <p>Telefon: +39 (0)2/92 36 52 70 Telefax: +39 (0)2/92 36 55 12</p>	<p>Italy <input checked="" type="checkbox"/> V/S <input checked="" type="checkbox"/> Service</p> <p>Mannesmann Rexroth S.p.A. Divisione INDRAMAT Via Borgomanero, 11 I - 10145 Torino</p> <p>Telefon: +39 (0)11/7 71 22 30 Telefax: +39 (0)11/7 71 01 90</p>	<p>Italy <input checked="" type="checkbox"/> V/S <input type="checkbox"/> Service</p> <p>Mannesmann Rexroth S.p.A. Divisione INDRAMAT Via del Progresso, 16 (Zona Ind.) I - 35020 Padova</p> <p>Telefon: +39 (0)49/8 70 13 70 Telefax: +39 (0)49/8 70 13 77</p>
<p>Italy <input type="checkbox"/> V/S <input checked="" type="checkbox"/> Service</p> <p>Mannesmann Rexroth S.p.A. Divisione INDRAMAT Via de Nicola, 12 I - 80053 Castellamare di Stabia NA</p> <p>Telefon: +39 (0)81/8 72 30 37 Telefax: +39 (0)81/8 72 30 18</p>	<p>Italy <input checked="" type="checkbox"/> V/S <input type="checkbox"/> Service</p> <p>Mannesmann Rexroth S.p.A. Divisione INDRAMAT Viale Oriani, 38/A I - 40137 Bologna</p> <p>Telefon: +39 (0)51/34 14 14 Telefax: +39 (0)51/34 14 22</p>	<p>Netherlands <input checked="" type="checkbox"/> V/S <input type="checkbox"/> Service</p> <p>Hydraudyne Hydrauliek B.V. Kruisbroeksestraat 1 P.O. Box 32 NL - 5281 RV Boxtel</p> <p>Telefon: +31 (0)411/65 19 51 Telefax: +31 (0)411/65 14 83</p>	<p>Netherlands <input type="checkbox"/> V/S <input checked="" type="checkbox"/> Service</p> <p>Hydrocare B.V. Kruisbroeksestraat 1 P.O. Box 32 NL - 5281 RV Boxtel</p> <p>Telefon: +31 (0)411/65 19 51 Telefax: +31 (0)411/67 78 14</p>
<p>Spain <input checked="" type="checkbox"/> V/S <input checked="" type="checkbox"/> Service</p> <p>Mannesmann Rexroth S.A. División INDRAMAT Centro Industrial Santiga Obradors s/n E-08130 Santa Perpetua de Mogoda Barcelona</p> <p>Telefon: +34 937 47 94 00 Telefax: +34 937 47 94 01</p>	<p>Spain <input checked="" type="checkbox"/> V/S <input checked="" type="checkbox"/> Service</p> <p>Goimendi S.A. División Indramat Jolastokieta (Herrera) Apartado 11 37 E - 20017 San Sebastian</p> <p>Telefon: +34 9 43/40 01 63 Telefax: +34 9 43/39 17 99</p>	<p>Sweden <input checked="" type="checkbox"/> V/S <input checked="" type="checkbox"/> Service</p> <p>Rexroth Mecman Svenska AB INDRAMAT Division Varuvägen 7 S - 125 81 Stockholm</p> <p>Telefon: +46 (0)8/727 92 00 Telefax: +46 (0)8/64 73 277</p>	<p>Switzerland - East <input checked="" type="checkbox"/> V/S <input checked="" type="checkbox"/> Service</p> <p>Mannesmann Rexroth AG Geschäftsbereich INDRAMAT Gewerbestraße 3 CH-8500 Frauenfeld</p> <p>Telefon: +41 (0)52/720 21 00 Telefax: +41 (0)52/720 21 11</p>
<p>Switzerland - West <input checked="" type="checkbox"/> V/S <input type="checkbox"/> Service</p> <p>Mannesmann Rexroth SA Département INDRAMAT Chemin de l'Ecole 6 CH-1036 Sullens</p> <p>Telefon: +41 (0)21/731 43 77 Telefax: +41 (0)21/731 46 78</p>	<p>Russia <input type="checkbox"/> V/S <input checked="" type="checkbox"/> Service</p> <p>Tschudnenko E.B. Arsenia 22 RUS - 153000 Ivanovo Rußland</p> <p>Telefon: +7 093/223 96 33 oder/or +7 093/223 95 48 Telefax: +7 093/223 46 01</p>	<p>Slowenia <input checked="" type="checkbox"/> V/S <input checked="" type="checkbox"/> Service</p> <p>DOMEL Elektromotorji in gospodinjiski aparati d. d. Otoki 21 SLO - 64 228 Zelezniki</p> <p>Telefon: +386 64/61 73 32 Telefax: +386 64/64 71 50</p>	<p>Turkey <input checked="" type="checkbox"/> V/S <input checked="" type="checkbox"/> Service</p> <p>Mannesmann Rexroth Hidropar A..S. Fevzi Cakmak Cad No. 3 TR - 34630 Sefaköy Istanbul</p> <p>Telefon: +90 212/541 60 70 Telefax: +90 212/599 34 07</p>

Europäische Kundenbetreuungsstellen (ohne Deutschland)
European Service agencies (without Germany)

Außerhalb Europa - outside Europe

<p>Argentina <input checked="" type="checkbox"/> V/S <input type="checkbox"/> Service</p> <p>Mannesmann Rexroth S.A.I.C. Division INDRAMAT Acassusso 48 41/7 RA - 1605 Munro (Buenos Aires)</p> <p>Telefon: +54 (0)1/756 01 40 +54 (0)1/756 01 36</p>	<p>Argentina <input type="checkbox"/> V/S <input checked="" type="checkbox"/> Service</p> <p>NAKASE Asesoramiento Tecnico Calle 49, No. 5764-66 RA - 1653 Villa Balester Provincia de Buenos Aires</p> <p>Telefon: +54 (0) 1/768 24 13 Telefax: +54 (0) 1/768 36 43</p>	<p>Australia <input checked="" type="checkbox"/> V/S <input checked="" type="checkbox"/> Service</p> <p>AIMS - Australian Industrial Machinery Services Pty. Ltd. Unit 3/45 Horne ST Campbellfield 3061 AUS - Melbourne, VIC</p> <p>Telefon: +61 (0)3/93 59 02 28 Telefax: +61 (0)3/93 59 02 66</p>	<p>Brazil <input checked="" type="checkbox"/> V/S <input checked="" type="checkbox"/> Service</p> <p>Mannesmann Rexroth Automação Ltda. Divisão INDRAMAT Rua Georg Rexroth, 609 Vila Padre Anchieta BR - 09951-270 Diadema-SP [Caixa Postal 377] [BR-09901-970 Diadema-SP]</p> <p>Telefon: +55 (0)11/745 90 60 +55 (0)11/745 90 70 Telefax: +55 (0)11/745 90 50</p>
<p>Canada <input checked="" type="checkbox"/> V/S <input checked="" type="checkbox"/> Service</p> <p>Basic Technologies Corporation Burlington Division 3426 Mainway Drive Burlington, Ontario Canada L7M 1A8</p> <p>Telefon: +1 905/335 55 11 Telefax: +1 905/335-41 84</p>	<p>China <input checked="" type="checkbox"/> V/S <input type="checkbox"/> Service</p> <p>Mannesmann Rexroth (China) Ltd. Shanghai Office - Room 206 Shanghai Internat. Trade Centre 2200 Yanan Xi Lu PRC - Shanghai 200335</p> <p>Telefon: +86 21/62 75 53 33 Telefax: +86 21/62 75 56 66</p>	<p>China <input type="checkbox"/> V/S <input checked="" type="checkbox"/> Service</p> <p>Mannesmann Rexroth (China) Ltd. Shanghai Parts & Service Center 199 Wu Cao Road, Hua Cao Minhang District PRC - Shanghai 201 103</p> <p>Telefon: +86 21/62 20 00 58 Telefax: +86 21/62 20 00 68</p>	<p>China <input checked="" type="checkbox"/> V/S <input type="checkbox"/> Service</p> <p>Mannesmann Rexroth (China) Ltd. 15/F China World Trade Center 1, Jianguomenwai Avenue PRC - Beijing 100004</p> <p>Telefon: +86 10/65 05 03 80 Telefax: +86 10/65 05 03 79</p>
<p>China <input checked="" type="checkbox"/> V/S <input type="checkbox"/> Service</p> <p>Mannesmann Rexroth (China) Ltd. A-5F., 123 Lian Shan Street Sha He Kou District PRC - Dalian 116 023</p> <p>Telefon: +86 411/46 78 930 Telefax: +86 411/46 78 932</p>	<p>Hongkong <input checked="" type="checkbox"/> V/S <input checked="" type="checkbox"/> Service</p> <p>Rexroth (China) Ltd. 19 Cheung Shun Street 1st Floor, Cheung Sha Wan, Kowloon, Hongkong</p> <p>Telefon: +852 27/41 13 51/-54 oder/or +852 27/41 14 30 Telefax: +852 27/86 07 33</p>	<p>India <input checked="" type="checkbox"/> V/S <input checked="" type="checkbox"/> Service</p> <p>Mannesmann Rexroth (India) Ltd. INDRAMAT Division Plot. 96, Phase III Peenya Industrial Area IND - Bangalore - 560058</p> <p>Telefon: +91 (0)80/8 39 21 01 Telefax: +91 (0)80/8 39 43 45</p>	<p>India <input checked="" type="checkbox"/> V/S <input type="checkbox"/> Service</p> <p>Mannesmann Rexroth (India) Ltd. INDRAMAT Division Plot. A-58, TTC Industrial Area Thane Turbhe Midc Road Mahape Village IND - Navi Mumbai - 400 701</p> <p>Telefon: +91 (0)22/7 61 46 22 Telefax: +91 (0)22/7 68 15 31</p>
<p>Indonesia <input checked="" type="checkbox"/> V/S <input type="checkbox"/> Service</p> <p>PT. Rexroth Wijayakusuma Jl. Raya Bekasi Km 21 Pulogadung RI - Jakarta Timur 13920</p> <p>Telefon: +62 21/4 61 04 87 +62 21/4 61 04 88 Telefax: +62 21/4 60 01 52</p>	<p>Japan <input checked="" type="checkbox"/> V/S <input checked="" type="checkbox"/> Service</p> <p>Rexroth Automation Co., Ltd. INDRAMAT Division 1F, I.R. Building Nakamachidai 4-26-44 Tsuzuki-ku, Yokohama-shi J - Kanagawa-ken 224-004</p> <p>Telefon: +81 459/42-72 10 Telefax: +81 459/42-03 41</p>	<p>Korea <input checked="" type="checkbox"/> V/S <input checked="" type="checkbox"/> Service</p> <p>Mannesmann Rexroth-Seki Co Ltd. 1500-12 Da-Dae-Dong ROK - Saha-Ku, Pusan, 604-050</p> <p>Telefon: +82 (0)51/2 60 06 18 Telefax: +82 (0)51/2 60 06 19</p>	<p>Korea <input checked="" type="checkbox"/> V/S <input type="checkbox"/> Service</p> <p>Seo Chang Corporation Ltd. Room 903, Jeail Building 44-35 Yeouido-Dong Yeoungdeungpo-Ku C.P.O.Box 97 56 ROK - Seoul</p> <p>Telefon: +82 (0)2/7 80 82 08 +82 (0)2/7 80 82 09 Telefax: +82 (0)2/7 84 54 08</p>
<p>Mexico <input checked="" type="checkbox"/> V/S <input type="checkbox"/> Service</p> <p>Rexroth Mexico S.A. de C.V. Calle Neptuno 72 Unidad Ind. Vallejo MEX - 07700 Mexico, D.F.</p> <p>Telefon: +52 5 754 17 11 +52 5 754 36 84 +52 5 754 12 60 Telefax: +52 5 754 50 73 +52 5 752 59 43</p>		<p>South Africa <input checked="" type="checkbox"/> V/S <input checked="" type="checkbox"/> Service</p> <p>HYTEC Automation (Pty) Ltd. 28 Banfield Road, Industria North RSA - Maraisburg 1700</p> <p>Telefon: +27 (0)11/673 20 80 Telefax: +27 (0)11/673 72 69</p>	<p>Taiwan <input checked="" type="checkbox"/> V/S <input type="checkbox"/> Service</p> <p>Rexroth Uchida Co., Ltd. No.1, Tsu Chiang Street Tu Cheng Ind. Estate Taipei Hsien, Taiwan, R.O.C.</p> <p>Telefon: +886 2/2 68 13 47 Telefax: +886 2/2 68 53 88</p>

Kundenbetreuungsstellen außerhalb Europa - Service agencies outside Europe

Außerhalb Europa / USA - outside Europe / USA

<p>USA <input checked="" type="checkbox"/> V/S <input checked="" type="checkbox"/> Service</p> <p>Mannesmann Rexroth Corporation INDRAMAT Division 5150 Prairie Stone Parkway USA - Hoffman Estates, IL 60192-3707 Telefon: +1 847/6 45 36 00 Telefax: +1 847/6 45 62 01</p>	<p>USA <input checked="" type="checkbox"/> V/S <input checked="" type="checkbox"/> Service</p> <p>Mannesmann Rexroth Corporation INDRAMAT Division Central Region Technical Center USA - Auburn Hills, MI 48326 Telefon: +1 248/3 93 33 30 Telefax: +1 248/3 93 29 06</p>	<p>USA <input checked="" type="checkbox"/> V/S <input checked="" type="checkbox"/> Service</p> <p>Mannesmann Rexroth Corporation INDRAMAT Division Southeastern Technical Center 3625 Swiftwater Park Drive USA - Suwanee Georgia 30174 Telefon: +1 770/9 32 32 00 +1 770/9 32 19 03</p>	<p>USA <input checked="" type="checkbox"/> V/S <input checked="" type="checkbox"/> Service</p> <p>Mannesmann Rexroth Corporation INDRAMAT Division Northeastern Technical Center 99 Rainbow Road USA - East Granby, Connecticut 06026 Telefon: +1 860/8 44 83 77 +1 860/8 44 85 95</p>
<p>USA <input checked="" type="checkbox"/> V/S <input checked="" type="checkbox"/> Service</p> <p>Mannesmann Rexroth Corporation INDRAMAT Division Charlotte Regional Sales Office 14001 South Lakes Drive USA - Charlotte, North Carolina 28273 Telefon: +1 704/5 83 97 62 +1 704/5 83 14 86</p>			

Kundenbetreuungsstellen außerhalb Europa / USA
Service agencies outside Europe / USA

Notes

