



CTA10 Feed-to-Length Operator Interface for the DKC

Application Description

DOK-SUPPL*-CTA10*R****-AW03-AE-P



Title	CTA10 Feed to Length Operator Interface for the DKC
Kind of Documentation	Application Description
Document Typecode	DOK-SUPPL*-CTA10*R****-AW03-AE-P • 07/99
Internal File Reference	120-2100-B310-03/AE
Purpose of this Document	This document is a reference manual for the CTA10 Feed to length control. It contains descriptions of the data screens and the logic required for its application.

Revision History

Revision	Date	Remarks
01	12/96	First edition, supports CTA10*-DK1-01VRS
02	02/97	Updated to support CTA10*DK1-02VRS
03	07/99	Updated to support CTA10*DK1-03VRS (includes ECODRIVE03)

Copyright © INDRAMAT GmbH, 1999

Copying this document, and giving it to others and the use or communication of the contents thereof without express authority, are forbidden. Offenders are liable for the payment of damages. All rights are reserved in the event of the grant of a patent or the registration of a utility model or design (DIN 34-1).

Validity All rights are reserved with respect to the content of this documentation and the availability of the product.

Published by Mannesmann Rexroth Indramat • 5150 Prairie Stone Parkway • Hoffman Estates, IL 60192 • Tel: (847) 645-3600 • Fax: (847) 645-6201

Dept. ESV03 (HK)

Contents

1 General Description	1-1
1.1 CTA10/DKC Interface	1-1
Other Documentation	1-1
New Features in Firmware Version 03VRS.....	1-2
Description of Features in Version 03VRS Roll Feed Firmware	1-2
1.2 Roll-Feed Press Configuration	1-3
1.3 Keyboard Functions	1-4
2 CTA10 Display	2-1
2.1 Display Overview.....	2-1
2.2 Main Display.....	2-1
2.3 Part Edit Display (F1)	2-1
2.4 Part Select Display (F2)	2-2
2.5 System Totals Display (F3).....	2-3
Press Permissive Interface (F3).....	2-3
Continuous Mode - Feed before Press	2-4
Intermittent Mode - Feed before Press	2-5
Continuous Mode - Press before Feed	2-6
Intermittent Mode - Press before Feed	2-7
2.6 System Data Display (F4)	2-8
System Inputs (F1).....	2-8
System Outputs (F2)	2-8
Versions (F3).....	2-8
2.7 Drive Status (F5).....	2-8
3 CTA10 Parameter Mode Display	3-1
3.1 Display Overview.....	3-1
3.2 Main Parameter Mode Display (ESC)	3-1
3.3 Part Data Display (F1).....	3-2
3.4 Drive Data Display (F2).....	3-2
DKC Parameter Display (F1).....	3-2
Archive Display (F2)	3-3
Restore Display (F3)	3-3
Load Default (F4) (if Measuring Wheel Inactive)	3-3
Measure Wheel (F4) (if Measuring Wheel Active – Available for ECODRIVE03 only)	3-3
3.5 System Data (F3).....	3-4
3.6 System Inputs Display (F4).....	3-5
3.7 Drive Status Display (F5)	3-5

4 CTA10 Input/Output System	4-1
4.1 CTA10 Inputs	4-1
4.2 CTA10 Outputs	4-1
4.3 Emergency Stop.....	4-2
5 CTA10 Modes	5-1
5.1 Overview	5-1
5.2 Parameter Mode	5-1
5.3 Initialization Mode.....	5-1
5.4 Manual Mode	5-1
5.5 Automatic Mode	5-1
6 CTA10 Diagnostics	6-1
6.1 Overview	6-1
6.2 System Status	6-1
Parameter Mode Status Text	6-1
Initialization Status Text	6-1
Manual Mode Status Text	6-1
Automatic Mode Status Text.....	6-2
Drive Warnings.....	6-2
6.3 System Faults	6-3
Hard Faults.....	6-3
Soft Faults	6-3
7 Drawings	7-1
7.1 CTA10 - DKC 1.1 Interconnect	7-1
7.2 CTA10 - DKC 1.3 Interconnect	7-2
7.3 CTA10 - Layout and Dimensions	7-3
8 Index	8-1

1 General Description

1.1 CTA10/DKC Interface

The CTA10 is an operator interface for the DKC drive which is used for roll feed applications. It controls the feeding of materials such as metal, foil or film through a shear, punch press, or a similar stamping machine.

The machine builder or user enters data into the DKC parameters (via the CTA10) to specify the mechanical and operating characteristics of the system.

The system is designed to ensure operating integrity and safety, using various inputs and outputs (I/O) to assure that the feeder and its subsequent processing station or device operates in harmony. A diagnostic system monitors I/O and operating conditions and stops the system if a fault is detected. Diagnostic messages are displayed to aid the operator in troubleshooting problems.

Other Documentation

This manual contains only CTA10-specific information for DKC roll feed applications contained in the DK1 Roll Feed Firmware. For detailed information about DKC parameters and other general DKC functionality, please consult the following manuals:

Title	Typecode	Material No.
ECODRIVE DKC combined with MKD Selection Lists	DOK-ECODRV-DKC+MKD****-AUS1-MS-P	261599
ECODRIVE DKC01.1/DKC11.1 Drive Controllers Project Planning Manual	DOK-ECODRV-DKC01/11.1*-PRJ3-EN-P	270950
ECODRIVE DKC1-ASE04 Functional Description	DOK-ECODRV-ASE-04VRS**-FKB1-EN-P	275270
ECODRIVE DKC1-ASE04 Troubleshooting Guide	DOK-ECODRV-ASE-04VRS**-WAR1-EN-P	275271
ECODRIVE DKC1-ASE04 Version Notes	DOK-ECODRV-ASE-04VRS**-FVN1-EN-P	275272
ECODRIVE DKC3-PDP03 Functional Description	DOK-ECODRV-PDP-03VRS**-FKB1-EN-P	274132
ECODRIVE DKC3-PDP03 Troubleshooting Guide	DOK-ECODRV-PDP-03VRS**-WAR1-EN-P	274133
ECODRIVE03 Drive Controllers Project Planning Manual	DOK-ECODR3-DKC**.3****-PRJ1-EN-P	280107
ECODRIVE03 Servo Applications with 1,5 s Acceleration Time -- Selection Lists	DOK-ECODR3-SERV-GEN***-AUS1-MS-P	281042
ECODRIVE03 Drive For General Automation with Profibus Interface -- Functional Description	DOK-ECODR3-FGP-01VRS**-FKB1-EN-P	279103
ECODRIVE03 Drive For General Automation with Profibus Interface -- Troubleshooting Guide	DOK-ECODR3-FGP-01VRS**-WAR1-EN-P	279104
ECODRIVE03 Drive For General Automation with Profibus Interface -- Firmware Version Notes	DOK-ECODR3-FGP-01VRS**-FVN1-EN-P	280278
ECODRIVE03 Drive for Machine Tool Applications with SERCOS-, Analog- and Parallel Interface Functional Description	DOK-ECODR3-SMT01VRS**-FKB1-EN-P	279087

Table 1-1: ECODRIVE Documentation

New Features in Firmware Version 03VRS

Note: ECODRIVE03 is the new generation in the ECODRIVE drive family (DKC drives), which has additional features and an increased power range. Please note that some of the new features in version 03VRS of the DK1 Roll Feed Firmware are supported only for ECODRIVE03.

Version 03VRS of the DK1 Roll Feed Firmware supports the following new features:

- support of the new ECODRIVE03 drive family, with firmware version SGP01V13 or higher
- measuring wheel support
- new system parameters:
 - measuring wheel on/off
 - configurable analog feedrate override for automatic mode (ECODRIVE03 only)
- faster baud rate (ECODRIVE03 only): 38,400 kbps
- support of the eight languages (ECODRIVE01 and ECODRIVE03):
 - Czechoslovakian (NEW) - English
 - French - German
 - Italian - Portuguese (NEW)
 - Spanish - Swedish (NEW)

Note: **For the ECODRIVE03 only:**
Upon each startup, the CTA10 remaps the I/O on the DKC 1.3, as shown in **Figure 7-2: CTA10 - DKC1.3 Interconnect**. Any unused I/O cannot be remapped.

Description of Features in Version 03VRS Roll Feed Firmware

Measuring Wheel (ECODRIVE03 only)

To compensate for the slip between the motor-driven roll feed and the sheet material, the position measurement can be performed with an additional measuring wheel instead of with the motor encoder. The torque to turn the measuring wheel is very low, so the slip is negligible. The measuring wheel must remain in constant contact with the sheet material or the position control loop will not be properly closed. If such constant contact is not possible, the position feedback must be switched back to the motor encoder.

Pin 5 on X15 is the digital input to switch the measuring wheel format on (24 V) or off (0 V). The status of this input is written to Parameter P-0-220, bit 1 (see table below).

Power to X15, pin 5	Digital value written to P-0-220, bit 1	Result
24V	1	measuring wheel active (position feedback from measuring wheel)
0V	0	measuring wheel inactive (position feedback from motor encoder)

To use the measuring wheel function, the following parameters must be adjusted (see your ECODRIVE03 manual for more information about how to set these parameters):

DKC Parameter #	Description
P-0-0075	Feedback 2 type
P-0-0121	Velocity mix factor feedback (0%) (<i>in development</i>)
P-0-0221	Measuring wheel filter time constant

S-0-0115	Position feedback type / direction (rotary or linear)
S-0-0117	Feedback 2 resolution (in mm or revolutions)
S-0-0123	Measuring wheel feed constant
S-0-0391	Monitoring window feedback (0 necessary)

Table 1-1: Measuring Wheel-Related DKC Parameters

Analog Feedrate Override

In any DKC drive, the system parameter "Analog Feedrate Override" can be set to provide an analog feedrate override signal to the drive, which will influence the drive velocity.

The standard scaling is that 10V is equivalent to the nominal or programmed velocity. 0V analog feedrate override causes a velocity of 0.

Using drive parameter P-0-0214, the scaling of the analog input voltage can be set (default = 3000). This parameter appears in the DKC parameter list.

1.2 Roll-Feed Press Configuration

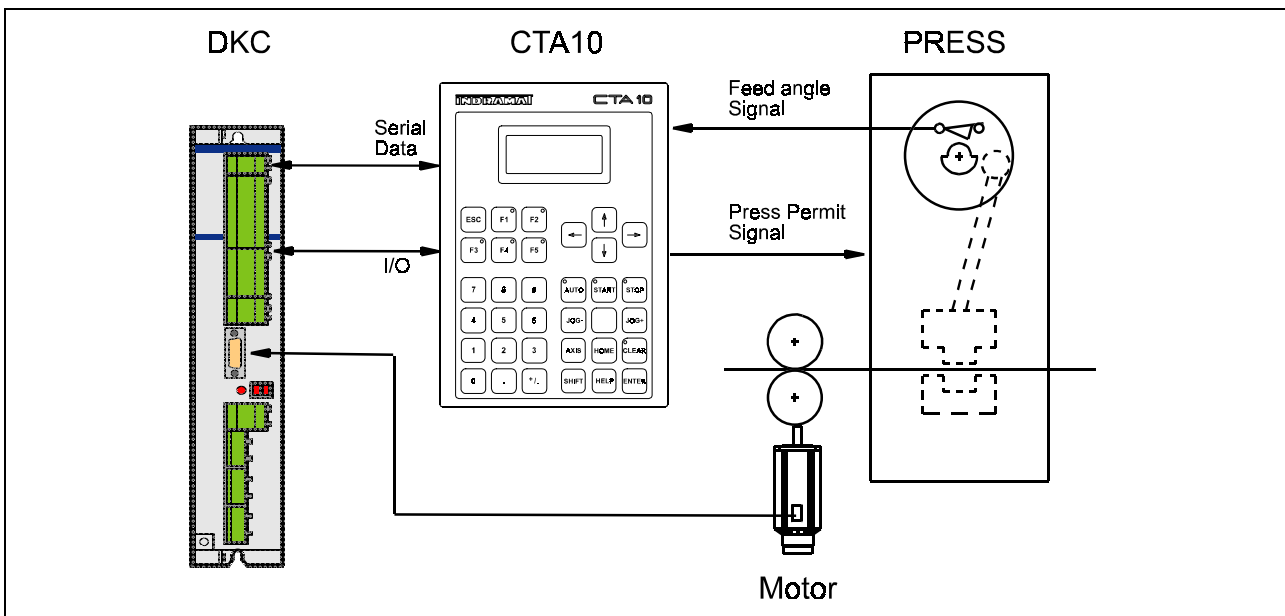

Figure 1-1: Configuration of a Roll-Feed Press

The CTA10 is capable of storing up to 105 part configurations in the FLASH EPROM. Each part can have a separate length, rate, velocity, acceleration and jerk. The operator selects the active part from the CTA10 interface. A new part can become active at any time, but only the length and speed data can be altered by the operator outside of parameter mode.

The CTA10 contains various system performance data and accumulators. It tracks the strokes per minute, time used, total length fed and total number of pieces run. It also has a part counter to allow simple batching.

1.3 Keyboard Functions

Note: For function keys F1-F5, the LED lights up when the key has been configured to perform a special function.



Figure 1-2: CTA10 Keyboard and Display

AUTO: Pressing this key while in manual mode will place the CTA10 in automatic mode. The LED will turn on indicating that it is in automatic mode. Pressing the key while in automatic mode will return the CTA10 to manual mode providing that the feeder is not cycling. If the feeder is cycling, press STOP and then press the AUTO key. If the cycle has not been completed, press SHIFT and STOP simultaneously, then press AUTO. The LED will turn off and the system will be in manual mode.

Arrow Keys: The arrow keys are used to select data fields and position the cursor in a field.

AXIS: This key has no operation. It is disabled.

CLEAR: The clear key is used to clear drive and feed angle lost errors. When clearing a drive error the CTA10 sends a serial command to reset the class 1 diagnostic error. If the drive is in an error state, the LED will be on. The clear key is only active when the LED is on. An operator should go to the drive status display (F5) to review the error message before clearing a drive error.

ENTER: The enter key is used to save entered data.

ESC: The escape key is used to close pop-up messages and return to the previous screen.

F5: The F5 key is used to jump to the drive status display. When the CTA10 detects a drive error, it will flash the LED on the F5 key.

HELP: When pressed, the page-specific help is displayed (in AUTO/MANUAL mode). Release the key to return to the display screen.

HOME: This key has no operation. It is disabled.

JOG+ / JOG- : When a jog key is pressed, the drive start signal (AH) is used to command motion and the position block mode is set to "Traverse in a positive/negative direction." The feedrate override is set to 100% for a normal jog. Pressing SHIFT-JOG will set the override to 10% so that a slow jog can be used. (This function is available only if Feedrate Override is disabled in System Parameter C-0-0018.) Jog keys are active only when the system is in manual mode.

SHIFT-Down: Decrement current field (micro-adjust). When micro-adjusting integer values, the number will change by 1. When micro-adjusting floating point values, the number will change according to system parameter C-0-0002 Micro-Adjust Value.

SHIFT-Up: Increment current field (micro-adjust). When micro-adjusting integer values, the number will change by 1. When micro-adjusting floating point values, the number will change according to system parameter C-0-0002 Micro-Adjust Value.

SHIFT-ESC (reboot): This key combination is used to reboot the CTA10. It has the same effect as power cycling the CTA10.

START: The cycle start key is only active in automatic mode. If the Press Interface parameter (C-0-0008) is set to press before feed, the START button will cause the CTA10 to look for a low-to-high transition on the Feed Angle Input and then begin cycling. When the feed before press mode is selected, the CTA10 will automatically cycle as soon as the Feed Angle Input is high.

STOP: The cycle stop key is only active in automatic mode while cycling. It will stop the feeder after the completion of the current cycle.

SHIFT-STOP: This key combination is used to stop the feeder immediately, even if the current cycle is not complete.

2 CTA10 Display

Note: These displays are accessible from AUTO or MANUAL modes only.

2.1 Display Overview

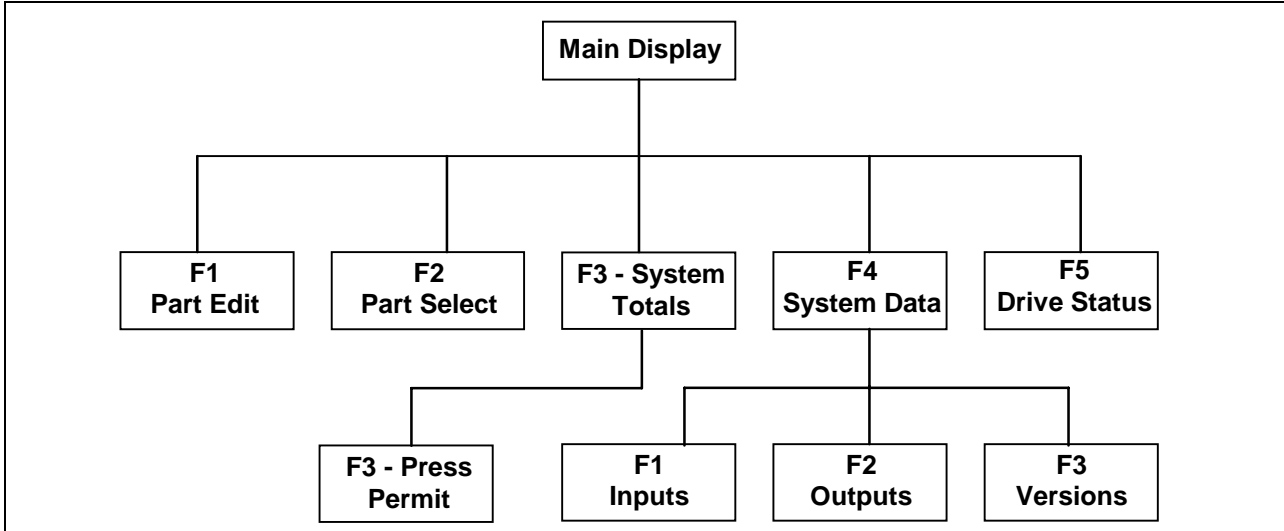

Figure 2-1: Display Overview

The boxes below indicate screen displays. The text on the left represents the normal screen display. The text on the right will be displayed when the help key is pressed. Press ESC to return to the previous screen.

2.2 Main Display

SYSTEM STATUS ACTIVE PART: 105 01234.567 in 12.34%	F1: PART EDIT F2: PART SELECT F3: SYSTEM TOTALS F4: SYSTEM DATA
--	--

The main page displays the active part number along with its length and rate. The system status is listed on the top line of the display. No editing can be done from this page.

2.3 Part Edit Display (F1)

SYSTEM STATUS EDIT PART: 105 LENGTH: 01234.567 RATE: 12.34%	Select Part To Edit. Part data will be stored immediately.
---	--

The operator can edit the length and rate for any part from the part edit page. Data for the currently executing part will be used on the next position cycle. The maximum velocity, acceleration and jerk associated with each part must be entered in parameter mode. The system status is listed on the top line of the display.

Note: Changes to the length and rate will be stored to the flash EPROM on a power cycle or when a new part is selected.

2.4 Part Select Display (F2)

SYSTEM STATUS	Enter QUANTITY = 0
SELECT PART: 105	for a free run.
QUANTITY: 123456	F1: INC. F2: DEC.
COUNT: 123456	F3: CLEAR COUNT

The operator selects the active **part number** from this screen. When a new part is selected the position block data will be sent immediately to the DKC. The new data will become active on the next cycle. The system status is listed on the top line of the display.

Note: The LED on the F1, F2 and F3 keys will be on to indicate that they have a special function while this screen is active.

The operator can enter the desired **quantity** of parts to run. Entering a quantity of 0 specifies a free run condition. The CTA10 will initiate part cycles until the count is greater than or equal to the quantity specified. At this point, the CTA10 will cycle stop and reset the part count value, or it will flash the Cycle Stop LED and continue cycling with the counter increasing. This option is selected in System Parameter **C-0-0011** - Batch Completion. *See Section 3.5 System Data (F3).*

The operator may alter the target quantity at any time during the run. Pressing the **F1** key will add a part to the count. Pressing **F2** will subtract a part from the count. Pressing **F3** will reset the count to 0. During a free run condition (quantity = 0) **F1** and **F2** are inactive.

2.5 System Totals Display (F3)

SYSTEM STATUS	
SPM: 0000 USE: 00%	F1: CLEAR LENGTH
L:1234567890.123	F2: CLEAR PIECES
PIECES: 123456	F3: PERMIT PRESS

The system totals display provides the user with the total length and the total pieces (cycles) fed. This information is retained through a power cycle. The counters are updated at the end of a cycle. Partial feeds are not counted. To clear the total length accumulator, press the **F1** key. To clear the total piece count accumulator, press the **F2** key.

Note: The LED on the F1 and F2 keys will be on to indicate that they have a special function while this screen is active.

The system status is listed on the top line of the display. The strokes per minute (**SPM:**) and time used (**USE:**) calculations are also listed on this display.

The **SPM** calculation tracks the time between high-to-low transitions of the feed angle. The time used calculation measures the percentage of time the feed consumes before the next high-to-low transition of the Feed Angle Input.

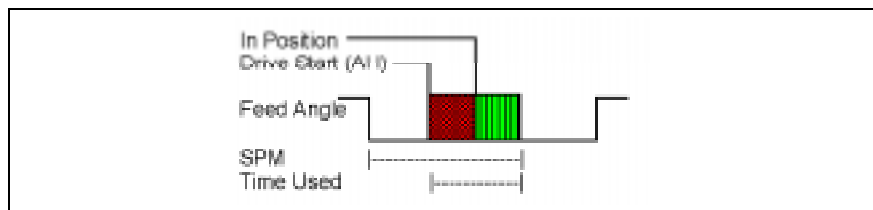

Figure 2-2: SPM Calculation

Press Permissive Interface (F3)

The Press Permissive Interface is a safety feature that generates a signal which can be used to engage or disengage the press clutch. A high signal permits clutch engagement for press cycle operation (if all other safety logic circuitry on the press is satisfied). A low signal disengages the clutch and press operation halts.

Warning: The machine builder should tie this signal into the other "Safety Logic Circuitry" for the press system. Do not use this signal to fire the press without regard for other safety conditions (interlocks open, machine E-Stop, etc.).

The Press Permit display includes the **System Status**, the value of the **Press Permit** signal, the Press Interface setting and the mode of operation. The Press Interface setting determines whether the system will **Feed before Press** or **Press before Feed**. **See Parameter C-0-0008 - Section 3.5 System Data (F3)**. The mode of operation can be **Continuous** or **Intermittent**. Use the left and right arrow keys to select

an operating mode. The ENTER key must be pressed to accept the change.

Continuous mode specifies continuous press cycling, synchronized with the material feed. **Intermittent** mode specifies that the press will be cycled on time at the end of, or just previous to, each feed cycle.

The timing of the Press Permit signal depends on the press interface setting and the mode of operation. See the timing charts illustrated below for the specific timing of this signal.

Continuous Mode - Feed before Press

SYSTEM STATUS	Press The ESC
Permit Press: 0	key to return
Feed then Press	to the System Totals
Continuous	display.

Permit Press is issued after the first feed is completed. In Continuous Mode, it remains high during the automatic cycling. It goes low if the control sees a fault or error, or if a Cycle Stop is issued.

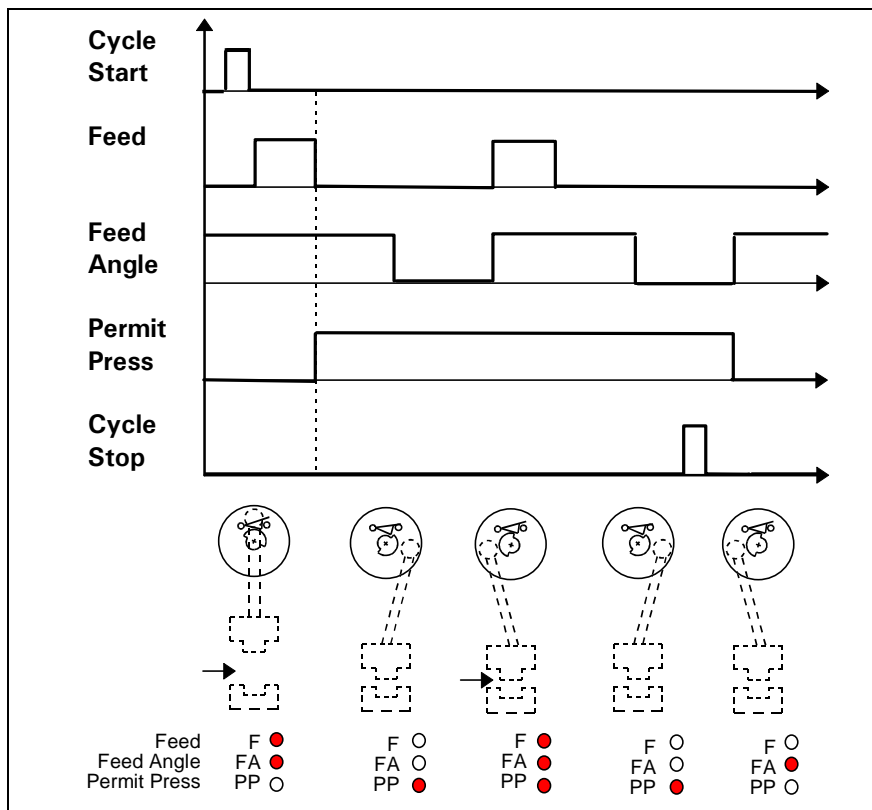

Figure 2-3: Permit Press timing chart - Continuous/Feed before Press

Intermittent Mode - Feed before Press

SYSTEM STATUS	Press The ESC
Permit Press: 0	key to return
Feed then Press	to the System Totals
Intermittent	display.

In Intermittent Mode, Permit Press is issued after a feed cycle is complete, and dropped when the feed angle becomes high or a cycle stop is issued.

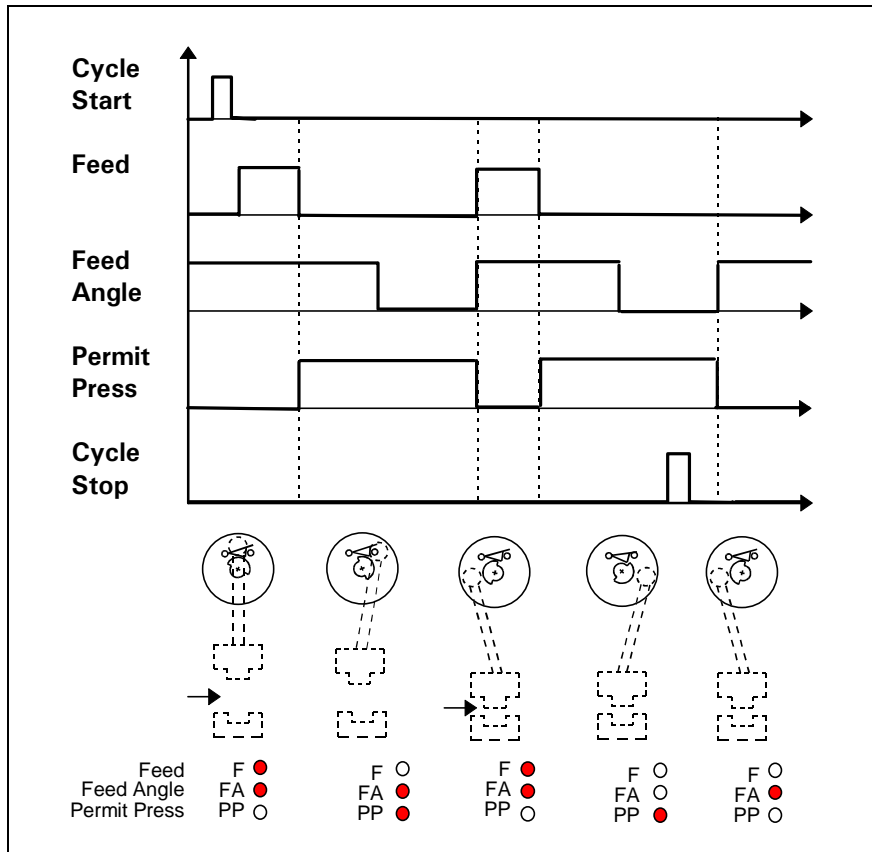

Figure 2-4: Permit Press timing chart - Intermittent/Feed before Press

Continuous Mode - Press before Feed

SYSTEM STATUS	Press The ESC
Permit Press: 0	key to return
Press then Feed	to the System Totals
Continuous	display.

Permit Press is issued after a Cycle Start. In continuous Mode, it remains high during the automatic cycling. It goes low if the control sees a fault or error, or a Cycle Stop is issued.

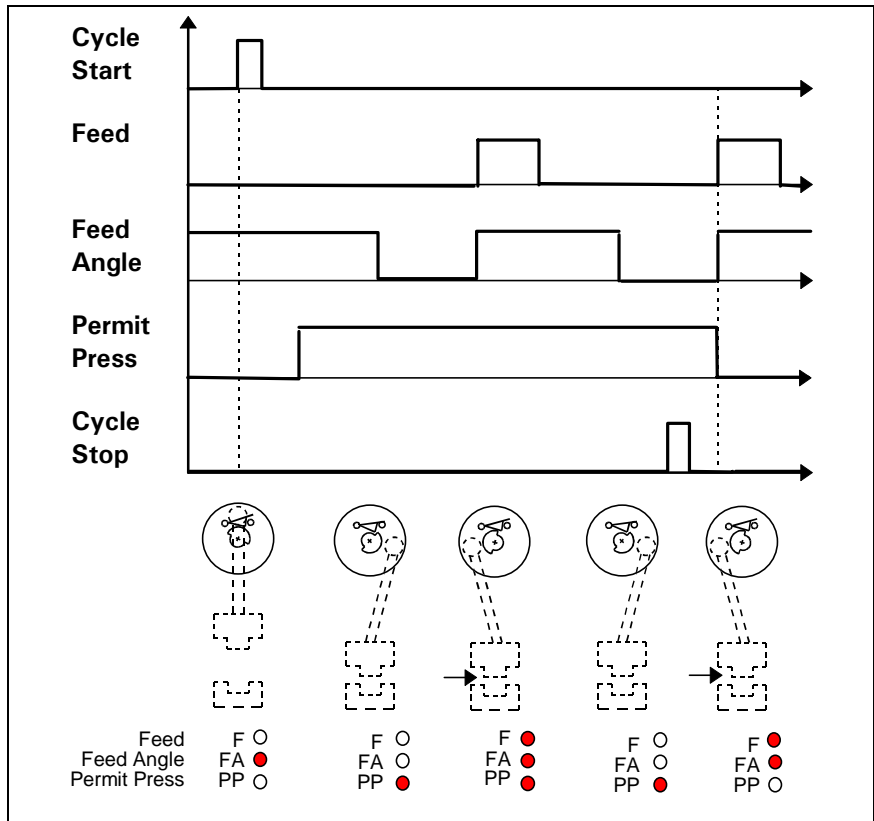

Figure 2-5: Permit Press timing chart - Continuous/Press before Feed

Intermittent Mode - Press before Feed

SYSTEM STATUS	Press The ESC
Permit Press: 0	key to return
Press then Feed	to the System Totals
Intermittent	display.

In Intermittent Mode, Permit Press is issued after a cycle start, and dropped when the feed angle becomes high. After a feed cycle is complete the Permit Press is issued again until the feed angle becomes high.

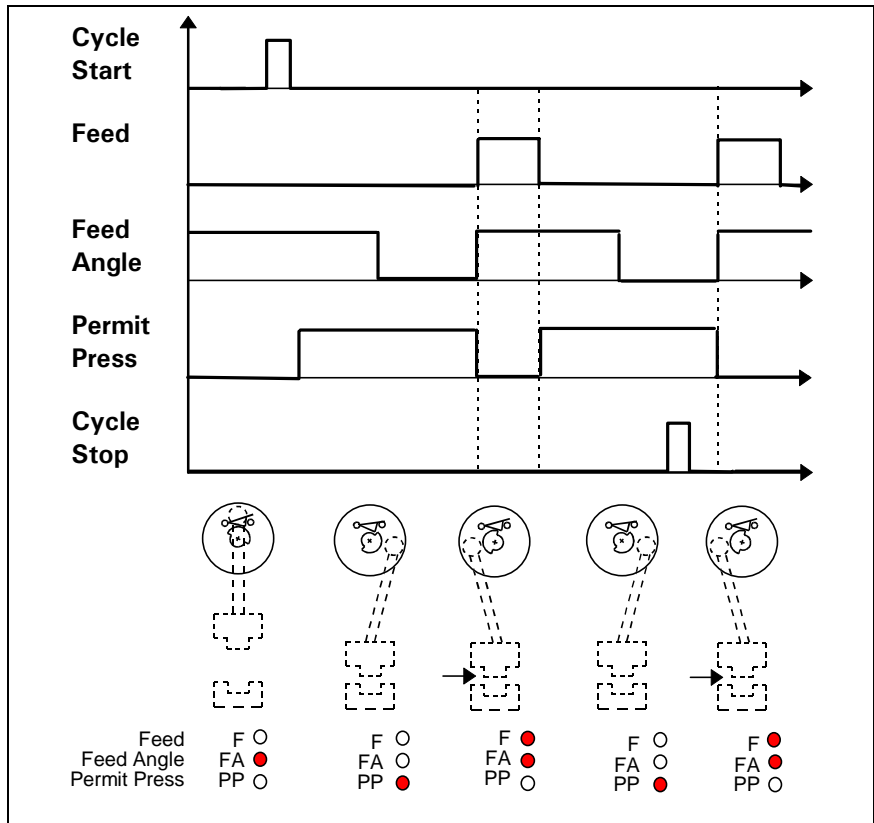

Figure 2-6: Permit Press timing chart - Intermittent/Press before Feed

2.6 System Data Display (F4)

SYSTEM STATUS	Press the ESC
F1: Inputs	key to return
F2: Outputs	to the previous
F3: Versions	display.

The System Data Display contains a sub menu which is used to select system data displays. Press the corresponding function key to view the desired display. The system status is listed on the top line of the display. *See Chapter 4. CTA10 Input/Output System for more information.*

System Inputs (F1)

Feed Angle: 0	Press The ESC
Param Mode: 0	key to return
In Motion: 0	to the previous
In Position: 0	display.

The system input display shows the current state for each of the four input signals. A one means the signal is high, and a zero means it is low. The system status is not listed on the top line of this display.

System Outputs (F2)

Drive Enable: 0	Press The ESC
Drive Start: 0	key to return
Permit Press: 0	to the previous
Manual Mode: 0	display.

The system output display shows the current state for each of the four output signals. A one means the signal is high, and a zero means it is low. The system status is not listed on the top line of this display.

Versions (F3)

SYSTEM STATUS	Press The ESC
CTA10*-DK1-03VRS	key to return
ESM2.1-SGP-01V13	to the previous
MKD025B-144-KG0	display.

The versions display shows the type codes for the CTA10, DKC and the motor. The system status is listed on the top line of the display.

2.7 Drive Status (F5)

SYSTEM STATUS	This screen displays the current system & drive status.
DRIVE STATUS	
MESSAGE	

The Drive Status display lists the system and drive status. The current drive diagnostic text is displayed on the lower three lines. This display can be viewed at any time by pressing the **F5** key.

3 CTA10 Parameter Mode Display

3.1 Display Overview

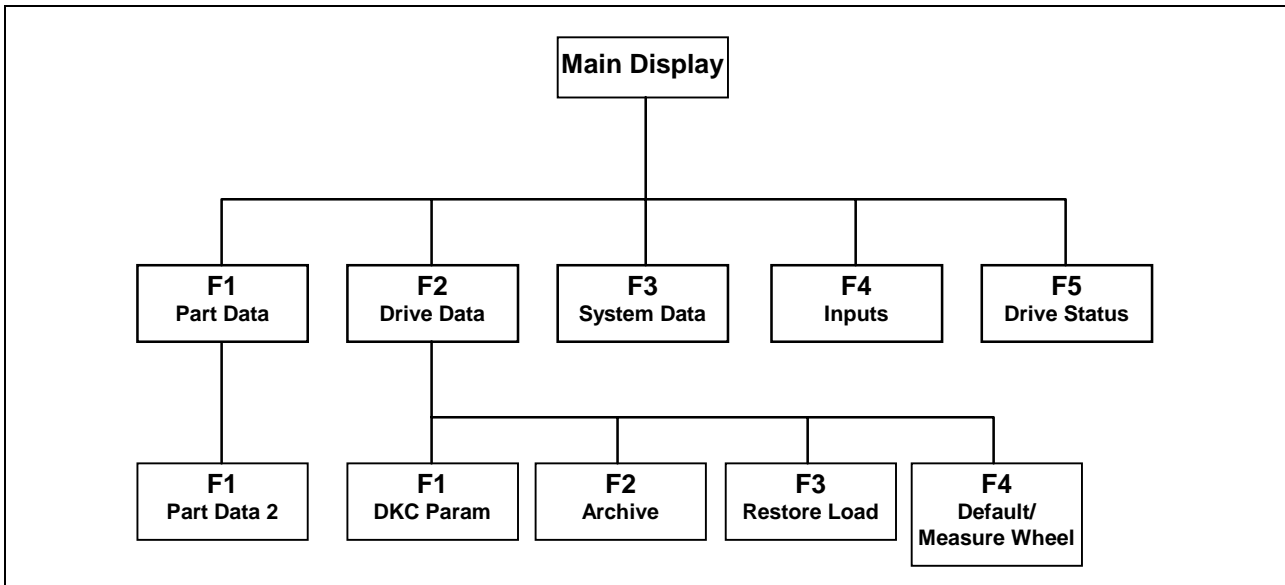

Figure 3-1: Parameter Mode Overview

The boxes below indicate screen displays. The text on the left represents the normal screen display. The text on the right will be displayed when the help key is pressed. Press ESC to return to the previous screen.

3.2 Main Parameter Mode Display (ESC)

F1: Part Data F2: Drive Data F3: System Data F4: Inputs
--

Upon entering parameter mode the above menu is displayed. Press the corresponding function key to access the desired data. Pressing the **F5** key will display the current drive status. The DKC will continue to be polled for drive errors while in parameter mode.

3.3 Part Data Display (F1)

PART NUMBER: 105	Press the F1
VEL: 12345.678	key to edit the
ACCEL:123456.78	length and rate
JERK: 1234567.8	data.

Press the **F1** key in the Part Data display to edit the parts length and rate. These values can also be edited from the **Part Edit Display (F1)** in normal operation mode. **See Section 2.3 Part Edit Display (F1).**

PART NUMBER: 105	Press the ESC
LENGTH: 01234.567	key to return
RATE: 12.30 %	to the previous
	display.

The part data display is used to enter separate velocity, acceleration, jerk, length and rate for each part. To select a part to edit, simply enter the part number. Use the up and down arrow keys to select the parameter data to edit. The parameters will be verified and saved to FLASH EPROM when exiting parameter mode or when selecting a new part to edit.

Note: When editing a new part, the velocity and acceleration will be defaulted to 100% of the current maximum settings in the DKC.

3.4 Drive Data Display (F2)

F1: ECODERIVE Prm.	Press the ESC
F2: Archive	key to return
F3: Restore	to the previous
F4: Load Default	display.

The drive data display is used to edit, archive or restore DKC parameters. The DKC can also be commanded to load its default list of parameter values.

DKC Parameter Display (F1)

PARAM. # UNITS	PARAM. # UNITS
Description	MAX VALUE
Value	MIN VALUE
	Maximum/Minimum

The DKC Parameter display is used to edit a limited set of DKC parameters. The parameter number, units, text description and data will be displayed. Press and hold the HELP key to view the minimum and maximum values for the parameter.

Note: A complete set of DKC parameters can be edited/viewed by pressing the "blank" key while on the Drive Data Display. **See**

Section 3.4 Drive Data Display (F2). The CTA10 will ask for a password before it uploads the list from the DKC. The password is currently "645-3600" (phone number for Indramat USA).

Archive Display (F2)

CONFIRM Archive Parameters YES NO
--

The Archive display allows the user to archive the set of DKC operational parameters from this listing. Parameters are saved in the flash EPROM on the CTA10. The operator will be prompted before this operation is done. Use the arrow keys to select "YES" or "NO" and then press enter.

Restore Display (F3)

CONFIRM Restore Parameters YES NO
--

The Restore display allows the user to restore the set of DKC operational parameters from this listing. Parameters are saved in the flash EPROM on the CTA10. The operator will be prompted before this operation is done. Use the arrow keys to select "Yes" or "No" and then press ENTER.

Load Default (F4)

(if Measuring Wheel Inactive)

CONFIRM Load Default Parameters YES NO

The Load Default display is used to set the default DKC parameters. This is done in parameter mode from the drive data screen. The CTA10 will issue the DKC command P-0-4094, followed by the command S-0-0262. The CTA10 will then send the set of forced configuration parameters. Next the DKC will be brought to phase 4 and back to phase 2 to force recalculation of the parameter set. If there are any invalid parameters found at this point, they will be set to the minimum or maximum value for that parameter. The operator will be prompted before this operation is done. Use the arrow keys to select "Yes" or "No" and then press ENTER.

Note: Following this command the CTA10 will default to metric units to match what the DKC has loaded. Please also note that the communication parameters will be reset to 9600 baud with an RS485 answer delay of 0.

Measure Wheel (F4)

(if Measuring Wheel Active – Available for ECODRIVE03 only)

When the measuring wheel (Parameter C-0-0019) is set to "Active," pressing F4 Measure Wheel from the Drive Data Display jumps to the screens for setting the parameters relevant to the measuring wheel. The

down-arrow allows scrolling through the parameter screens, in the following order:

S-0115	Position feedback type / direction (rotary or linear)
S-0117	Feedback 2 resolution (in mm or rotations)
S-0123	Measuring wheel feed constant
S-0391	Monitoring window feedback (0)
P-0075	Feedback 2 type
P-0221	Measuring wheel filter time constant
P-0121	Velocity mix factor feedback (0%) (<i>in development</i>)

For example:

S-0115 Position feedback 2 type 0000000000001001

3.5 System Data (F3)

Parameter Name and description

C-0-0000	Language: Czechoslovakian, English, German, French, Italian, Portuguese, Spanish and Swedish
C-0-0001	Units (inches, mm)
C-0-0002	Micro-Adjust Value: Amount used to adjust floating point numbers
C-0-0003	Max. Length: Greatest length an operator can enter.
C-0-0004	Min. Length: Smallest length an operator can enter.
C-0-0005	Max. Change In Length: The largest change in length an operator can enter while cycling in automatic mode.

Entering zero for one of the length parameters (C-0-0002 - C-0-0005) will disable that feature. If the operator enters a value outside the configured parameter ranges, the CTA10 will modify the data. No error message will be generated. The maximum and minimum DKC length limits are also still in force.

C-0-0006	Position Polarity: Selects if the motor should turn in a positive or negative direction.
C-0-0007	Slip Distance: Selects whether the DKC will Operate with lag or without.
C-0-0008	Press Interface: Selects press before feed or feed before press.
C-0-0009	Press Mode (continuous/intermittent)
C-0-0010	Press Time Out (minutes). If the CTA10 does not see a transition on the feed angle signal within the specified interval while cycling in automatic mode, a fault will be generated.
C-0-0011	Batch Completion: Select to cycle stop on completion, or flash the cycle stop LED and continue cycling.
C-0-0012	Flash: Static usage display
C-0-0013	Serial Baud Rate
C-0-0014	RS485 Delay Time
C-0-0015	Highest Station Address

- C-0-0016** Version: CTA10*DK1-03VRS (firmware code)
Date (firmware date)
- C-0-0017** Feed Angle Filter (ms)
- C-0-0018** Feed Rate Override (enable/disable)
- C-0-0019** Measuring Wheel (enable/disable)

3.6 System Inputs Display (F4)

Feed Angle:	0	Press the ESC
Param Mode:	0	key to return
In Motion:	0	to the previous
In Position:	0	display.

The system input display shows the current state for each of the four input signals. A "1" means the signal is high, and a "0" means it is low. This screen is useful when configuring the monitoring windows, or testing I/O wiring.

3.7 Drive Status Display (F5)

SYSTEM STATUS	This screen
DRIVE STATUS	displays the
MESSAGE	current system
	& drive status.

The Drive Status display lists the system and drive status. The current drive diagnostic text is displayed on the lower three lines. This display can be viewed at any time by pressing the F5 key.

4 CTA10 Input/Output System

The CTA10 contains 4 digital inputs and outputs. The outputs require an external 24 volt power supply. The input voltage should be 24 volts. All I/O connections are located on connector X4. The following table indicates the pin assignments.

4.1 CTA10 Inputs

- X4 1: Feed Angle
- X4 2: Parameter Mode
- X4 3: In Motion
- X4 4: In Position

Feed Angle Input: This signal comes from the press. When the press is up the Feed Angle Input is high. When the press is down the Feed Angle Input is low. The CTA10 will not allow jogging when this input is low. If the Feed Angle Input goes low during a feed cycle, the motion will be halted and the DKC will cycle stop. The error diagnostic "Feed Angle Lost" will be displayed.

Parameter Mode Input: The Parameter Mode Input should be connected to a keyed input. When this input is high the CTA10 will enter parameter mode. No motion is allowed while in parameter mode. Any motion in progress will be halted. The DKC will be forced into phase 2.

In Motion Input: The In Motion Input comes from the DKC. This signal is high if the axis is rotating at a velocity greater than the velocity tolerance window.

In Position Input: The In Position Input comes from the DKC. This signal is high when the DKC is within the position tolerance window.

4.2 CTA10 Outputs

- X4 5: Drive Enable (RF)
- X4 6: Drive Start/Stop (AH) – DKC 1.1
Block Start – DKC 1.3
- X4 7: Permit Press
- X4 8: Manual Mode Indicator

Drive Enable Output: The Drive Enable Output should be connected to the RF Input on the DKC. This signal will be low if the CTA10 is in parameter mode, or during a fatal error condition.

Drive Start/Stop Output: The Drive Start/Stop Output should be connected to the AH Input on the DKC. The output is set high while cycling in automatic mode or while jogging in manual mode.

Permit Press Output: This signal is configurable by a parameter to operate in Continuous or Intermittent modes (C-0-0009). It also takes into account the Press Interface selection of Press then Feed or Feed then Press (C-0-0008). This signal will only be high while cycling in auto mode. **See section 2.5 Press Permissive Interface (F3).**

Manual Mode Indicator Output: This output is high in manual mode and it can be used to enable the external jogging function or it can be wired to an indicator.

4.3 Emergency Stop

A separate Emergency Stop (E-Stop) palm button will be required to remove incoming 3 phase power from the DKC. **There is no E-Stop available from the CTA10 operator interface.** To halt the DKC more quickly, the E-Stop logic may remove the drive enable signal. The CTA10 polls the drive state and will recover if this signal is removed.

5 CTA10 Modes

5.1 Overview

The CTA10 has four basic modes of operation. Motion is only possible in manual mode and automatic mode.

5.2 Parameter Mode

The CTA10 enters parameter mode when there is a high signal detected on the Parameter Mode Input. **See 4.1 CTA10 Inputs.** The system will stay in this mode while the Parameter Mode Input is high. Before exiting this mode the integrity of the parameter system is verified. While in this mode all CTA10 outputs will be low. Exiting this mode will switch the CTA10 into initialization mode.

5.3 Initialization Mode

The CTA10 enters this mode directly from parameter mode or if there is a drive or feed angle error. All CTA10 outputs are brought low when entering this mode. The system will remain in this mode until the DKC is ready for operation. After the system determines that the DKC is ready, the CTA10 will switch into manual mode. The drive enable signal is brought up before exiting this mode.

5.4 Manual Mode

In manual mode the Drive Start Signal will be low. Jogging will be permitted only when the Feed Angle Input is high. The Feed Angle Input is scanned while in manual mode. If this signal goes low while the DKC is in motion (i.e. jogging) the system will set the feed angle lost error condition and drop into initialization mode. This means that the CTA10 will monitor loss of feed angle even if an external device is using the jog inputs on the DKC.

5.5 Automatic Mode

Automatic mode is entered by pressing the AUTO key while in manual mode. The AUTO key LED will turn on indicating that it is in automatic mode. The system will return to manual mode by pressing the AUTO key again as long as you are not cycling. While in automatic mode, pressing the START key will continuously cycle the DKC using position block data for the active part.

When operating in "Press Before Feed" mode the system will set the Drive Start/Stop (AH) Output high when it sees a low to high transition on the Feed Angle Input. In "Feed Before Press" mode the cycle will begin as soon as the Feed Angle Input is high. The system will reset the Drive Start/Stop Output when it determines that the DKC has reached its target position (In Position Input is high). If the system sees the Feed Angle Input go low before the DKC is in position, the feed angle lost error condition will be set and the CTA10 will drop into initialization mode.

6 CTA10 Diagnostics

6.1 Overview

The top line of most of the displays is reserved for the system diagnostic text. This text messages are used to describes the system state and error conditions. Communication errors are not part of the diagnostic system. They are enunciated with a pop-up window.

6.2 System Status

During normal operation the top line of the CTA10 display will show a system status message. The following descriptions list each of the status messages.

Parameter Mode Status Text

PARAMETER MODE: The CTA10 is in parameter mode.

Initialization Status Text

SETTING PHASE 2: The DKC is being set to phase 2.
 INITIALIZING: The CTA10 is in initialization mode.
 SETTING PHASE 3: The DKC is being set to phase 3.
 SETTING PHASE 4: The DKC is being set to phase 4.

Manual Mode Status Text

MANUAL MODE: The CTA10 is in manual mode.
 JOG FORWARD: The CTA10 is jogging the DKC forward.
 JOG REVERSE: The CTA10 is jogging the DKC in reverse.
 AXIS IN MOTION: The In Motion Output is high. This may also indicate that someone is jogging with an optional Jog Pendant.

Automatic Mode Status Text

AUTOMATIC MODE:	The CTA10 is in Automatic Mode waiting for cycle start.
AWAIT PRESS:	Waiting for the Feed Angle Input to go low while cycling in Automatic Mode.
AWAIT FEED ANGLE:	Waiting for the Feed Angle Input to go high while cycling in Automatic Mode.
AWAIT IN MOTION:	Waiting for the In Motion Input to go high while cycling in Automatic Mode.
FEEDING:	Waiting for the In Position Input to go high while cycling in Automatic Mode.
BATCH COMPLETE:	The CTA10 has reached the target count and cycle stop was selected for the Batch Completion Parameter (C-0-0009).
COMPLETING FEED:	A Cycle Stop has been selected in Automatic Mode but is delayed until the current part completes its cycle feed.
CYCLE STOP:	A Cycle Stop has been selected after running in Automatic Mode.

Drive Warnings

DRIVE DISABLED:	The Drive Enable Output from the CTA10 is not reaching the DKC Drive Enable Input. Check the wiring and the connections.
DRIVE NOT READY:	The DKC has not reached the AB state. Press F5 to view drive status. Refer to the DKC manual for corrective action.

6.3 System Faults

The CTA10 will continuously poll the DKC for drive faults. When an error is detected the LED on the CLEAR key will light and the LED on the **F5** key will flash. The operator should look at the drive status display for the error text.

Hard Faults

A Hard Fault is a Drive fault that forces the CTA10 into initialization mode. All outputs will be dropped (including the RF signal) and the DKC will cycle stop. (The RF signal is not dropped until the DKC *In Motion Output* is low.) The error is cleared when the operator presses the CLEAR key.

The following is a brief description of the fault messages.

DRIVE ERROR:	A DKC fault has been detected. Press F5 to view drive error. Refer to the DKC manual for corrective action.
FEED ANGLE LOST:	<p>The Feed Angle Input went low while the In Motion Input was high, <i>or</i> while jogging in Manual Mode.</p> <p>Check the input connection from the Feed Angle Switch. Ensure that the mechanical functions and timing are sequenced properly. Decrease the feed length or increase the feed rate.</p>

Soft Faults

A Soft Fault will cause the DKC to cycle stop, however it will not drop the RF signal and it will not force the CTA10 into initialization mode. The error is cleared when the operator presses the CLEAR key.

The following is a brief description of the fault messages.

PRESS TIME OUT:	If the CTA10 does not see a transition on the feed angle signal within the specified interval while cycling in automatic mode, a fault is generated.
MOTION TIME OUT:	A fault is generated if the CTA10 does not receive an "In Motion" input signal from the DKC within one second after a Cycle Start.

6.4 Firmware Errors (Troubleshooting)

The following table describes the firmware error codes that are displayed on the CTA10 screen.

Error Code	Description	Possible Cause	Remedy
2	Bus error.	The CPU has detected a bus error.	Contact Indramat Service.
3	Address error.	The CPU has detected an address error.	Contact Indramat Service.
4	Illegal instruction.	The CPU was instructed to execute an unknown instruction. Most likely a problem with the EPROM.	Contact Indramat Service.
5	Divide by zero.	The CPU has caught a divide by zero error.	Contact Indramat Service.
8	Privilege violation.	The CPU was instructed to execute a supervisory level instruction while in user mode.	Contact Indramat Service.
24	Spurious interrupt.	The CPU has received an interrupt from an unknown source.	Replace the hardware.
300	Dynamic memory allocation failed.	Software error indicating heap is corrupt.	Reboot hardware. If problem persists, contact Indramat Service.
301	Hardware failure (keyboard).	Self-diagnostic test found a stuck key during initialization.	Check the connector cable between the keyboard and hardware. If the problem persists, replace the hardware.
302	Incorrect hardware revision (keyboard).	During initialization it was determined that the revision level of the keyboard was wrong. Could indicate a hardware error or a change in hardware.	Contact Indramat Service
303	Incorrect hardware revision (main board).	During initialization it was determined that the revision level of the main board was wrong. Could indicate a hardware error or a change in hardware.	Contact Indramat Service
304	Power fail detected.	Can be seen if the CPU detects an undervoltage condition.	Check the 24-volt power supply.
305	Error initializing serial port.	The self-test of the serial port failed.	Reboot. If the problem persists replace the hardware.
306	Initialization of the operating system failed.	If this error persists, it could indicate a problem with the EPROM or RAM.	Contact Indramat Service.
307	Initialization of the LCD failed.	If the problem persists, it indicates a hardware error.	Contact Indramat Service.
308	Software failure.	Software bug.	Contact Indramat Service.
309	Stack overflow.	Software error indicating that the task's allocated stack space has been exceeded.	Contact Indramat Service.
310	Invalid FLASH EPROM type.	During initialization an unsupported FLASH EPROM type was detected. Could indicate a hardware or manufacturing error.	Contact Indramat Service.
311	FLASH EPROM failed.	The maximum write cycle limit to the FLASH EPROM has been exceeded.	Replace the hardware.

Table 6-1: Firmware Errors

7 Drawings

7.1 CTA10 - DKC 1.1 Interconnect

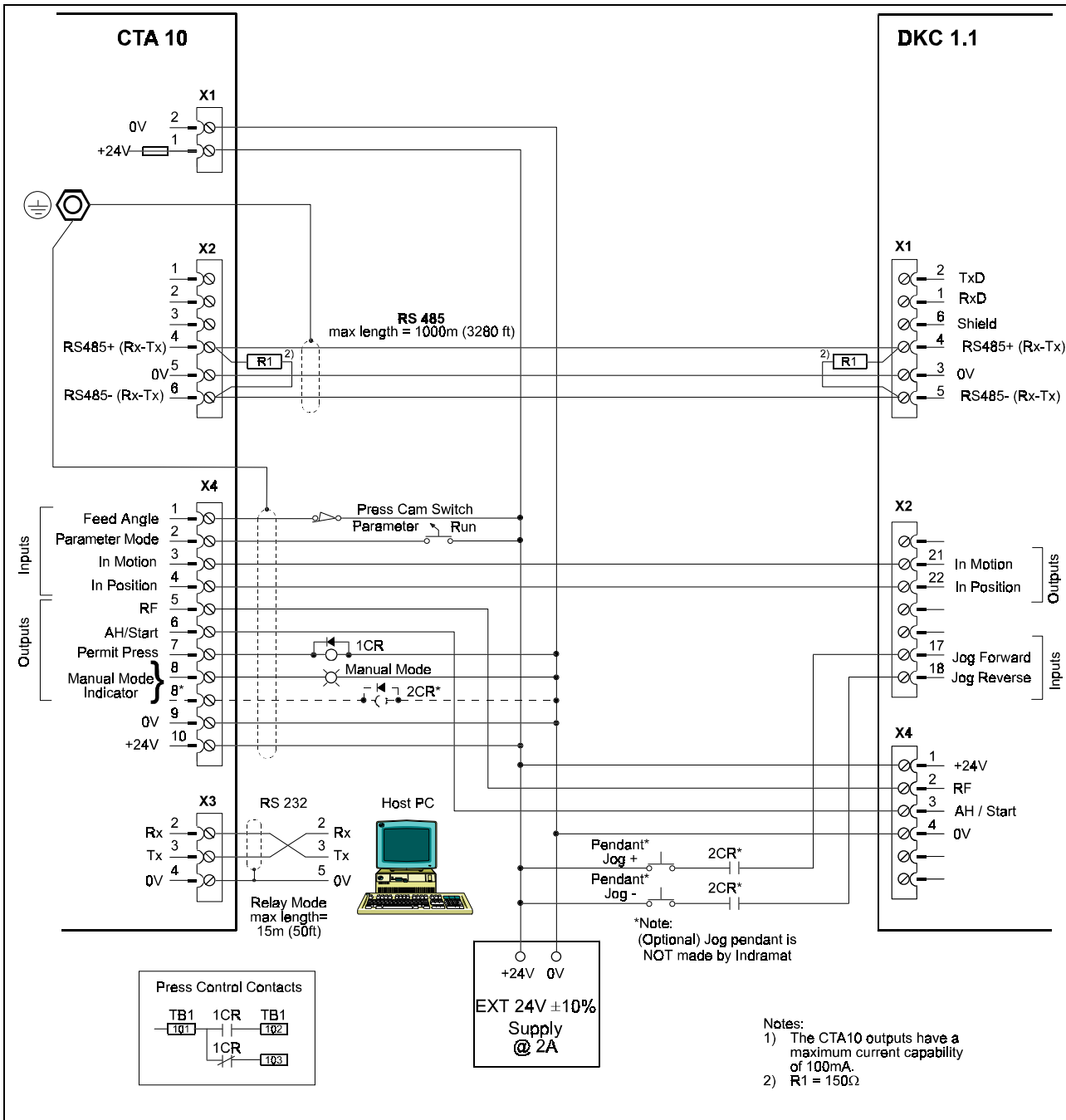

Figure 7-1: CTA10 - DKC1.1 Interconnect

7.2 CTA10 - DKC 1.3 Interconnect

Note: Upon each startup, the CTA10 remaps the I/O on the DKC 1.3, as shown in Figure 7-2: CTA10 - DKC1.3 Interconnect. Any unused I/O cannot be remapped.

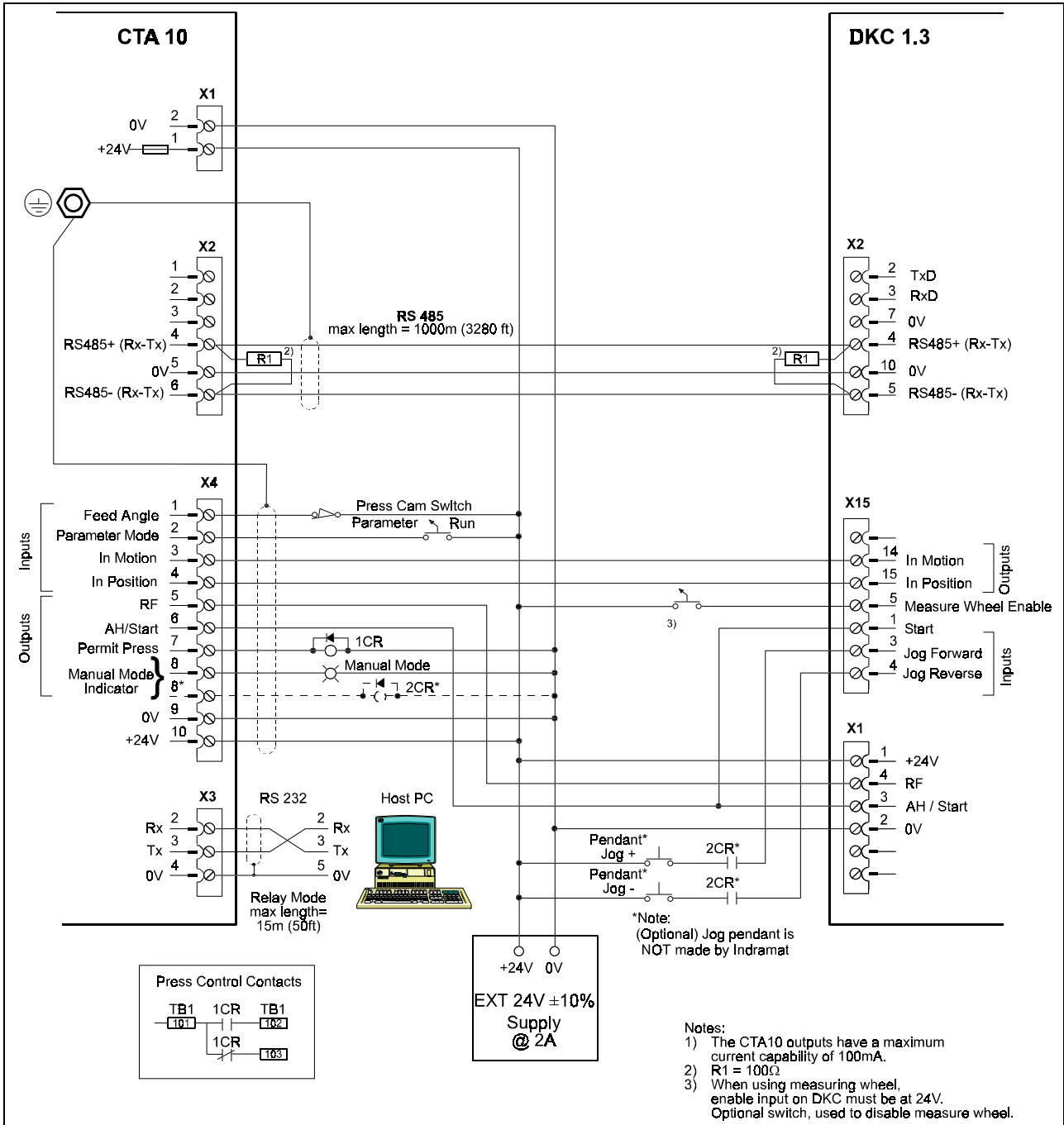

Figure 7-2: CTA10 - DKC1.3 Interconnect

7.3 CTA10 - Layout and Dimensions

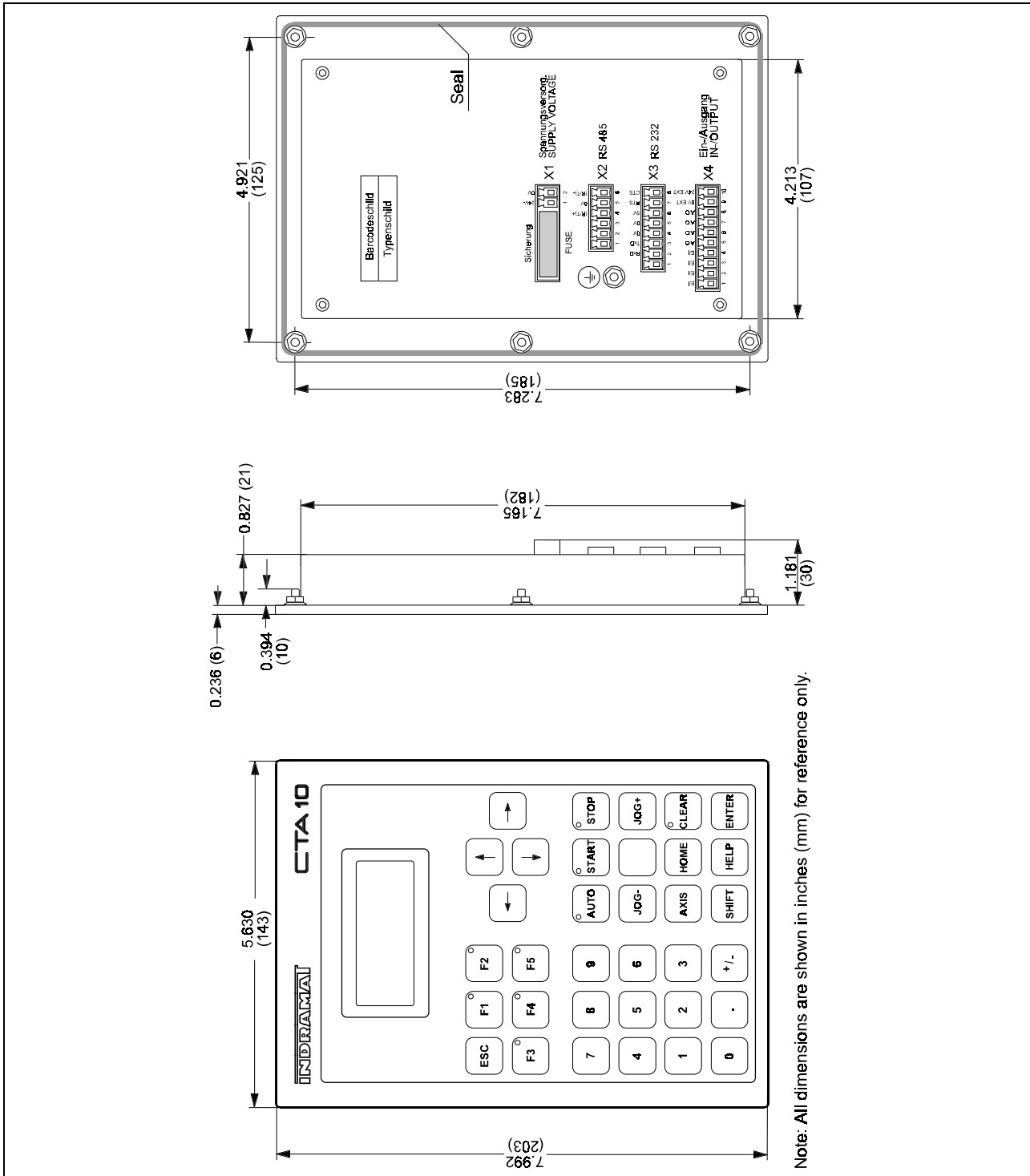

Figure 7-3: CTA10 - Layout and Dimensions

8 Index

A

Archive Display 3-3
 Automatic Mode 5-1, 6-2
 Automatic Mode Status Text 6-2
 AWAIT FEED ANGLE 6-2
 AWAIT IN MOTION 6-2
 AWAIT PRESS 6-2

B

BATCH COMPLETE 6-2
 Batch Completion 3-4

C

C-0000 3-4
C-0001 3-4
C-0002 3-4
C-0003 3-4
C-0004 3-4
C-0005 3-4
C-0006 3-4
C-0007 3-4
C-0008 3-4
C-0009 3-4
C-0010 3-4
C-0011 3-4
C-0012 3-4
C-0013 3-4
C-0014 3-4
C-0015 3-4
C-0016 3-4
 COMPLETING FEED 6-2
 Continuous Mode
 Feed before Press 2-4
 Press before Feed 2-6
 CTA10 - DKC Interconnect 7-1
 CTA10/DKC Interface 1-1
 CYCLE STOP 6-2

D

Diagnostics 6-1
 Display 2-1
 Display Overview 2-1
 DKC Parameter Display 3-2
 Drawings 7-1
 Drive Data Display 3-2
 DRIVE DISABLED 6-2
 DRIVE ERROR 6-3
 DRIVE NOT READY 6-2

Drive Status 2-9
 Drive Status Display 3-5
 Drive Warnings 6-2

E

Emergency Stop 4-2

F

FEED ANGLE LOST 6-3
 FEEDING 6-2
 Firmware Code 3-4
 flash EPROM 2-2
 Flash: Static usage display 3-4

G

General Description 1-1

H

HARD FAULTS 6-3
 Highest Station Address 3-4

I

Initialization Mode 5-1
 Initialization Status Text 6-1
 INITIALIZING 6-1
 Input/Output System 4-1
 Inputs 4-1
 Intermittent Mode
 Feed before Press 2-5
 Press before Feed 2-7

J

JOG FORWARD 6-1
 JOG REVERSE 6-1

L

Language 3-4
 Load Default 3-3

M

Main Display (Esc) 2-1
 Manual Mode 5-1
 Manual Mode Status Text 6-1
 Max. Change In Length 3-4
 Max. Length 3-4
 Micro-Adjust Value 3-4
 Min. Length 3-4
 MOTION TIME OUT 6-3

O

Operating Modes 5-1

Outputs 4-1

P

Parameter Mode 5-1

Parameter Mode Display 3-1

Parameter Mode Status Text 6-1

Part Data Display 3-2

Part Edit Display (F1) 2-2

Part Select Display (F2) 2-2

Position Polarity 3-4

Press Interface 3-4

Press Mode 3-4

Press Permissive Interface 2-3

Press Time Out 3-4, 6-3

R

Restore Display 3-3

RS485 Delay Time 3-4

S

Serial Baud Rate 3-4

SETTING PHASE 2 6-1

SETTING PHASE 4 6-1

Slip Distance 3-4

SOFT FAULTS 6-3

System Data 3-4

System Data Display 2-8

System Faults 6-3

System Inputs 2-8

System Inputs Display 3-5

System Outputs 2-8

System Status 6-1

System Totals Display (F3) 2-3

U

Units 3-4

V

Versions 2-8

Customer Service

Americas (United States, Canada, and Latin America)

USA Rexroth Corporation INDRAMAT Division 5150 Prairie Stone Parkway Hoffman Estates, Illinois 60192 Phone: 847/645-36 00 Fax: 847/645-62 01	USA Rexroth Corporation INDRAMAT Division 2110 Austin Avenue Rochester Hills, Michigan 48309 Phone: 810/853-82 90 Fax: 810/853-82 90	INDRAMAT Service Hotlines USA: 1-800-860-1055 Canada: 1-847-645-3600 (request Service Department) Latin America: (US Phone No.) 847-645-3600 (request Service Department)	Canada Basic Technologies Corporation Burlington Division 3426 Mainway Drive Burlington, Ontario Canada L7M 1A8 Phone: 905/335-55 11 Fax: 905/335-41 84
Mexico Motorización y Diseño de Controles, S.A. de C.V. Av. Dr. Gustavo Baz No. 288 Col. Parque Industrial la Ioma Apartado Postal No. 318 54060 Tlalnepantla Estado de Mexico Mexico Phone: 5/397 86 44 Fax: 5/398 98 88	Argentina Mannesmann Rexroth S.A.I.C. Division INDRAMAT Acassuso 48 41/7 1605 Munro (Buenos Aires) Argentina Phone: 01/756 01 40 01/756 02 40 Telex: 262 66 rexro ar Fax: 01/756 01 36	Argentina Nakase Asesoramiento Tecnico Diaz Velez 2929 1636 Olivos (Provincia de Buenos Aires) Argentina Phone: 01/790 52 30	Brazil Mannesmann Rexroth Automação Ltda. Divisão INDRAMAT Rua Georg Rexroth, 609 Vila Padre Anchieta BR-09.951-250 Diadema-SP Caixa Postal 377 BR-09.901-970 Diadema-SP Phone: 011/745 90 65 011/745 90 70 Fax: 011/745 90 50

Customer Service in the Americas

Asia, Australia, and Far East

Australia Australian Industrial Machinery Services Pty. Ltd. Unit 3/45 Horne ST Campbellfield VIC 2061 Australia Phone: 03/93 59 0228 Fax: 03/93 59 02886	China Rexroth (China) Ltd. Shanghai Office Room 206 Shanghai Intern. Trade Centre 2200 Yanan Xi Lu Shanghai 200335 P.R. China Phone: 021/627 55 333 Fax: 021/627 55 666	China Rexroth (China) Ltd. Shanghai Parts & Service Centre 199 Wu Cao Road, Hua Cao Minhang District Shanghai 201 103 P.R. China Phone: 021/622 00 058 Fax: 021/622 00 068	China Rexroth (China) Ltd. 1430 China World Trade Centre 1, Jianguomenwai Avenue Beijing 100004 P.R. China Phone: 010/50 50 380 Fax: 010/50 50 379
China Rexroth (China) Ltd. A-5F., 123 Lian Shan Street Sha He Kou District Dalian 116 023 P.R. China Phone: 0411/46 78 930 Fax: 0411/46 78 932	Hong Kong Rexroth (China) Ltd. 19 Cheung Shun Street 1st Floor, Cheung Sha Wan, Kowloon, Hong Kong Phone: 741 13 51/-54 or 741 14 30 Telex: 3346 17 GL REX HX Fax: 786 40 19 786 07 33	India Mannesmann Rexroth (India) Ltd. INDRAMAT Division Plot. 96, Phase III Peenya Industrial Area Bangalore - 560058 India Phone: 80/839 21 01 80/839 73 74 Telex: 845 5028 RexB Fax: 80/839 43 45	Japan Rexroth Co., Ltd. INDRAMAT Division I.R. Building Nakamachidai 4-26-44 Tsuzuki-ku, Yokohama 226 Japan Phone: 045/942-72 10 Fax: 045/942-03 41
Korea Rexroth-Seki Co Ltd. 1500-12 Da-Dae-Dong Saha-Gu, Pusan, 604-050 Korea Phone: 051/264 90 01 Fax: 051/264 90 10	Korea Seo Chang Corporation Ltd. Room 903, Jeail Building 44-35 Yoido-Dong Youngdeungpo-Ku Seoul, Korea Phone: 02/780-82 07 ~9 Fax: 02/784-54 08		

Customer Service in Asia, Australia, and the Far East

Europe

Austria G.L.Rexroth Ges.m.b.H. Geschäftsbereich INDRAMAT Hägelingasse 3 A-1140 Wien Phone: 1/9852540-400 Fax: 1/9852540-93	Austria G.L.Rexroth Ges.m.b.H. Geschäftsbereich INDRAMAT Randlstraße 14 A-4061 Pasching Phone: 07229/4401-36 Fax: 07229/4401-80	Belgium Mannesmann Rexroth N.V.-S.A. INDRAMAT Division Industrielaan 8 B-1740 Ternat Phone: 02/5823180 Fax: 02/5824310	Denmark BEC Elektronik AS Zinkvej 6 DK-8900 Randers Phone: 086/447866 Fax: 086/447160
England Mannesmann Rexroth Ltd. INDRAMAT Division 4 Esland Place, Love Lane Cirencester, Glos GL7 1YG Phone: 01285/658671 Fax: 01285/654991	Finland Rexroth Mecman OY Riihimiehentie 3 SF-01720 Vantaa Phone: 0/848511 Fax: 0/846387	France Rexroth - Sigma S.A. Division INDRAMAT Parc des Barbanniers 4, Place du Village F-92632 Gennevilliers Cedex Phone: 1/41475430 Fax: 1/47946941	France Rexroth - Sigma S.A. Division INDRAMAT 91, Bd 1 Joliot Curie F-69634 Venissieux - Cx Phone: 78785256 Fax: 78785231
France Rexroth - Sigma S.A. Division INDRAMAT 270, Avenue de lardenne F-31100 Toulouse Phone: 61499519 Fax: 61310041	Italy Rexroth S.p.A. Divisione INDRAMAT Via G. Di Vittoria, 1 I-20063 Cernusco S/N.MI Phone: 02/92365-270 Fax: 02/92108069	Italy Rexroth S.p.A. Divisione INDRAMAT Via Borgomanero, 11 I-10145 Torino Phone: 011/7712230 Fax: 011/7710190	Netherlands Hydraudyne Hydrauliek B.V. Kruisbroeksestraat 1a P.O. Box 32 NL-5280 AA Boxtel Phone: 04116/51951 Fax: 04116/51483
Spain Rexroth S.A. Centro Industrial Santiago Obradors s/n E-08130 Santa Perpetua de Mogoda (Barcelona) Phone: 03/718 68 51 Telex: 591 81 Fax: 03/718 98 62	Spain Goimendi S.A. División Indramat Jolastokieta (Herrera) Apartado 11 37 E-San Sebastian, 20017 Phone: 043/40 01 63 Telex: 361 72 Fax: 043/39 93 95	Sweden AB Rexroth Mecman INDRAMAT Division Varuvägen 7 S-125 81 Stockholm Phone: 08/727 92 00 Fax: 08/64 73 277	Switzerland Rexroth SA Département INDRAMAT Chemin de l'Ecole 6 CH-1036 Sullens Phone: 021/731 43 77 Fax: 021/731 46 78
Switzerland Rexroth AG Geschäftsbereich INDRAMAT Gewerbestraße 3 CH-8500 Frauenfeld Phone: 052/720 21 00 Fax: 052/720 21 11	Russia Tschudnenko E.B. Arsenia 22 153000 Ivanovo Russia Phone: 093/22 39 633		

Customer Service in Europe

Germany

Central Sales Region INDRAMAT GmbH Bgm.-Dr.-Nebel-Str. 2 D-97816 Lohr am Main Phone: 09352/40-0 Fax: 09352/40-4885	Eastern Sales Region INDRAMAT GmbH Beckerstraße 31 D-09120 Chemnitz Phone: 0371/3555-0 Fax: 0371/3555-230	Western Sales Region INDRAMAT GmbH Hansastraße 25 D-40849 Ratingen Phone: 02102/4318-0 Fax: 02102/41315	Northern Sales Region INDRAMAT GmbH Fährhausstraße 11 D-22085 Hamburg Phone: 040/227126-16 Fax: 040/227126-15
Southern Sales Region INDRAMAT GmbH Ridlerstraße 75 D-80339 München Phone: 089/540138-30 Fax: 089/540138-10	Southwestern Sales Region INDRAMAT GmbH Böblinger Straße 25 D-71229 Leonberg Phone: 07152/972-6 Fax: 07152/972-727	INDRAMAT Service Hotline INDRAMAT GmbH Phone: 0172/660 040 6 -or- Phone: 0171/333 882 6	

Customer Service in Germany

Notes

