



## ECODRIVE03/DURADRIVE Drives for General Automation with SERCOS and Parallel Interface

Firmware Version Notes: SGP 20VRS

SYSTEM200

<b>Title</b>	ECODRIVE03/DURADRIVE Drives for General Automation with SERCOS and Parallel Interface
<b>Type of Documentation</b>	Firmware Version Notes
<b>Document Typecode</b>	DOK-DRIVE*-SGP-20VRS**-FV02-EN-P
<b>Internal File Reference</b>	Box set: 72-20V-EN Based on: SGP 20VRS Document number: 120-0850-B311-02
<b>Purpose of Documentation</b>	This documentation offers an overview of the functionality of the firmware FWA-DRIVE*-SGP-20VRS and describes the differences between this firmware and its previous version FWA-ECODR3-SGP-01VRS.  In the "Summary" chapter, the texts of the functions and parameters that have been changed or added since the previous version FWA-ECODR3-SGP-01VRS are marked with gray background color.

<b>Record of Revisions</b>	<b>Description</b>	<b>Release Date</b>	<b>Notes</b>
	DOK-DRIVE*-SGP-20VRS**-FV01-EN-P	06.2001	First edition
	DOK-DRIVE*-SGP-20VRS**-FV02-EN-P	01.2002	Release

**Copyright** © 2002 Rexroth Indramat GmbH

Copying this document, giving it to others and the use or communication of the contents thereof without express authority, are forbidden. Offenders are liable for the payment of damages. All rights are reserved in the event of the grant of a patent or the registration of a utility model or design (DIN 34-1).

**Validity** The specified data is for product description purposes only and may not be deemed to be guaranteed unless expressly confirmed in the contract. All rights are reserved with respect to the content of this documentation and the availability of the product.

**Published by** Rexroth Indramat GmbH  
Bgm.-Dr.-Nebel-Str. 2 • D-97816 Lohr a. Main  
Telephone +49 (0)93 52/40-0 • Tx 68 94 21 • Fax +49 (0)93 52/40-48 85  
<http://www.boschrexroth.de/>  
Dept. EDF2/EDY (th/mw/hm/bb)

**Note** This document has been printed on chlorine-free bleached paper.

## Summary of Documentation - Overview

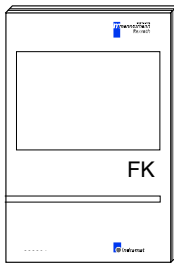

**Functional Description:**

Description of all implemented functions based on SERCOS parameters

Order designation:  
DOK-DRIVE\*-SGP-20VRS\*\*-FK01-EN-P

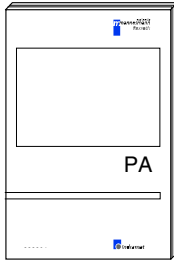

**Parameter Description:**

A description of all parameters used in the firmware

Order designation:  
DOK-DRIVE\*-SGP-20VRS\*\*-PA01-EN-P

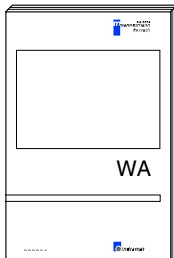

**Troubleshooting Guide:**

- Explanation of the diagnostic states
- How to proceed when eliminating faults

Order designation:  
DOK-DRIVE\*-SGP-20VRS\*\*-WA01-EN-P

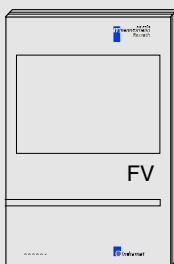

**Firmware Version Notes:**

Summary of the functionalities of the new firmware and of the changes since the previous version  
FWA-ECODR3-SGP-01VRS-MS

Order designation:  
DOK-DRIVE\*-SGP-20VRS\*\*-FV02-EN-P

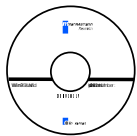

**CD: DRIVEHELP**

Collection of Windows help systems which contain documents on firmware derivatives

Order designation:  
DOK-GENERL-DRIVEHELP\*\*-GEXX-MS-D0600

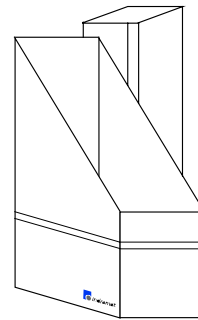

Order designation  
DOK-DRIVE\*-SGP-20VRS\*\*-7201-EN-P

## Notes

# Contents

<b>1</b>	<b>General Information</b>	<b>1-1</b>
1.1	Firmware Types .....	1-1
1.2	Release Notes.....	1-1
1.3	Drive Controllers .....	1-2
1.4	Overview of Operating Modes.....	1-2
<b>2</b>	<b>Replacing the Firmware</b>	<b>2-1</b>
2.1	Notes on How to Replace the Firmware .....	2-1
2.2	Firmware Replacement Procedure .....	2-2
<b>3</b>	<b>Summary FWA-DRIVE*-SGP-20VRS-MS</b>	<b>3-1</b>
3.1	Master Communication Interfaces .....	3-1
	SERCOS Interface.....	3-1
	Parallel Interface (with ECODRIVE03 Only).....	3-1
	Analog Interface (with ECODRIVE03 Only).....	3-2
3.2	Basic Operating Modes.....	3-3
	Torque/Force Control.....	3-3
	Velocity Control.....	3-4
	Position Control.....	3-5
	Drive-Internal Interpolation.....	3-6
	Drive-Controlled Positioning .....	3-7
	Positioning Block Mode.....	3-8
	Jogging.....	3-9
	Velocity Synchronization with Virtual Master Axis .....	3-10
	Phase Synchronization with Virtual Master Axis.....	3-11
	Electronic Cam Shaft with Virtual Master Axis.....	3-13
	Velocity Synchronization with Real Master Axis .....	3-15
	Phase Synchronization with Real Master Axis .....	3-17
	Electronic Cam Shaft with Real Master Axis .....	3-19
3.3	Controller Structure .....	3-21
3.4	Motor Types .....	3-22
	Motor Holding Brake .....	3-22
3.5	Measuring Systems.....	3-23
	Motor Encoder .....	3-23
	Optional Measuring System.....	3-23
	Absolute Measuring Systems .....	3-24
	Establishing the Position Reference for Actual Values.....	3-25
3.6	Physical Values Display Formats.....	3-26

3.7	Error Reactions .....	3-26
3.8	General Functions.....	3-26
	Comprehensive Diagnostic System.....	3-26
	Parameterization.....	3-26
	Language Selection .....	3-27
	Drive Halt .....	3-27
	Analog Inputs.....	3-27
	Analog Output.....	3-27
	Oscilloscope Function.....	3-27
	Probe Function.....	3-28
	Detecting the Marker Position.....	3-29
	Measuring Wheel Mode .....	3-29
	Parking Axis .....	3-29
	Backup Working Memory Procedure .....	3-30
	Programmable Limit Switch .....	3-30
	Incremental Encoder Emulation (TTL format) .....	3-30
	Absolute Encoder Emulation (SSI format).....	3-31
	Automatic Controller Setting .....	3-31
	Automatic Commutation Setting .....	3-31
	Digital Inputs/Outputs.....	3-31
	Master Axis of Master Axis Encoder.....	3-32
	Master Axis of Master Drive.....	3-32
	Virtual Master Axis Generator.....	3-33
3.9	EcoX – Expansion Interface for Digital Drives .....	3-34
	Overview .....	3-34
	Command Value Linkage.....	3-35
	I/O Extension.....	3-35
3.10	DISC Drive Macros .....	3-36
<b>4</b>	<b>New Fields of Application</b>	<b>4-1</b>
	EcoX.....	4-1
	DISC Drive Macros .....	4-1
	Master Axis Generator .....	4-2
	Measuring Wheel Mode .....	4-2
<b>5</b>	<b>Functional Changes with Regard to the Previous Version</b>	<b>5-1</b>
5.1	Incompatible Functional Changes.....	5-1
5.2	Functions No Longer Available .....	5-1
5.3	Deleted Parameters .....	5-1
5.4	New Parameters .....	5-2
5.5	Modified Parameters .....	5-3
<b>6</b>	<b>Index</b>	<b>6-1</b>

<b>7</b>	<b>Service &amp; Support</b>	<b>7-1</b>
7.1	Helpdesk .....	7-1
7.2	Service-Hotline .....	7-1
7.3	Internet .....	7-1
7.4	Vor der Kontaktaufnahme... - Before contacting us.....	7-1
7.5	Kundenbetreuungsstellen - Sales & Service Facilities .....	7-2

## Notes



# 1 General Information

## 1.1 Firmware Types

For the ECODRIVE03/DURADRIVE drive families there are three firmware types for different applications:

- **SMT**: Drives for Machine Tool Applications with SERCOS and Parallel Interface
- **SGP**: Drives for General Automation with SERCOS and Parallel Interface
- **FGP**: Drives for General Automation with Field Bus Interfaces

These Version Notes relate to the firmware version:

**ECODRIVE03/DURADRIVE**  
 Drives for General Automation  
 with SERCOS and Parallel Interface  
**FWA-DRIVE\*-SGP-20VRS-MS**

Using this documentation it is possible to quickly obtain an overview of the functionalities of this firmware.

In addition, this documentation describes the differences between the firmware version FWA-DRIVE\*-SGP-20VRS and the previous version FWA-ECODR3-SGP-01VRS. These differences are marked with gray background color in the "Summary" chapter.

The following drive controllers can be operated with the firmware released:

DKC21.3-040-7-FW	DKC21.3-100-7-FW	DKC21.3-200-7-FW
DKC22.3-040-7-FW	DKC22.3-100-7-FW	DKC22.3-200-7-FW
HDC01.1-A040N-SE02	HDC01.1-A100N-SE02	HDC01.1-A200N-SE02

## 1.2 Release Notes

The general distribution of the firmware version 20 starts as of the **FWA-DRIVE\*-SGP-20V12** firmware release.

This firmware was released on: **16/01/2002**

---

**Note:** The commissioning of the drive firmware version **FWA-DRIVE\*-SGP-20VRS-MS** requires the DriveTop version **SWA-DTOP\*\*\*-INB-14VRS-MS-C1,44-COPY** (or higher).

---

## 1.3 Drive Controllers

With the SMT, SGP and FGP (all 20VRS) firmware types it is possible to operate all drive controllers of the ECODRIVE03/DURADRIVE ranges. The differences between the devices are due to different current ratings and different device concepts (interfaces, supported motor types and measuring systems).

**Interfaces** Apart from a serial interface, there are the following master communication interfaces available:

Master communication interface	FWA	ECODRIVE03	DURADRIVE
<b>SERCOS</b>	SMT, SGP (all 20VRS)	DKC22.3-xxx-7-FW	HDC01.1-AxxxN-SE02
<b>Analog</b>	SMT, SGP (all 20VRS)	DKC21.3-xxx-7-FW	no
<b>Parallel</b>	SMT, SGP (all 20VRS)	DKC21.3-xxx-7-FW	no
<b>INTERBUS</b>	FGP20VRS	DKC04.3-xxx-7-FW	HDC01.1-AxxxN-IB01
<b>PROFIBUS</b>	FGP20VRS	DKC03.3-xxx-7-FW	HDC01.1-AxxxN-PB01
<b>CANopen</b>	FGP20VRS	DKC05.3-xxx-7-FW	HDC01.1-AxxxN-CN01
<b>DeviceNet</b>	FGP20VRS	DKC06.3-xxx-7-FW	HDC01.1-AxxxN-DN01

Fig. 1-1: Master communication interfaces

## 1.4 Overview of Operating Modes

Operating mode	FWA	ECODRIVE03	DURADRIVE
<b>torque/force control</b>	SMT, SGP, FGP (all 20VRS)	yes	only possible via MCM (e.g. SERCOS)
<b>velocity control</b>	SMT, SGP, FGP (all 20VRS)	yes	only possible via MCM (e.g. SERCOS)
<b>position control</b>	SMT, SGP, FGP (all 20VRS)	yes	yes
<b>drive-internal interpolation</b>	SMT, SGP, FGP (all 20VRS)	yes	yes
<b>drive-controlled positioning</b>	SMT, SGP, FGP (all 20VRS)	yes	yes
<b>jogging</b>	SMT, SGP, FGP (all 20VRS)	yes	only possible via MCM (e.g. SERCOS)
<b>positioning block mode</b>	SMT, SGP, FGP (all 20VRS)	yes	only possible via MCM (e.g. SERCOS)
<b>synchronous operating modes with virtual master axis</b>	SGP, FGP (all 20VRS)	yes	yes
<b>synchronous operating modes with real master axis</b>	SGP, FGP (all 20VRS)	yes	yes

Fig. 1-2: Operating modes (MCM: master communication module)

## 2 Replacing the Firmware

### 2.1 Notes on How to Replace the Firmware

When replacing the firmware, please observe the following:

1. The drive controller must be on.
2. The current parameters must be saved.
3. The drive controller must be in phase 2.
4. The baud rate must be set to 9600  
(the value '0' must be set in the parameter **P-0-4021, Baud rate RS-232/485**).

---

**Note:** Do not switch off the 24V control voltage while replacing the firmware!

---

## 2.2 Firmware Replacement Procedure

The following description applies to the firmware replacement with Dolfi V1.05 or newer (SWA-DOL\*PC-INB-01V05-MS-C1.44-COPY, part number 279804).

1. Call Dolfi.
2. Input the following under **Options**:
  - Tab page **Interface**
    - Under **COM Port** select interface to PC.
    - Under **Baud rate connect** set '9600'.
    - Under **Baud rate download** set baud rate for download (recommended setting: '115200').
  - Tab page **Address**
    - Enter the address set at switches S2 and S3 on the drive controller.
  - Tab page **Language**
    - Select language.
3. Press **Connect** button.
4. Press **Transmit** button.
  - The Windows standard dialog for opening a file opens.
5. Select \*.ibf file for update and open file.
  - The headers of the programmed modules are read. (You can view the headers that have been read by selecting the tab page **Header**.)
6. Press **Send** button.
  - If "Module – All" has been selected, the complete \*.ibf file is sequentially programmed without query (an ECODRIVE03/DURADRIVE firmware normally contains three firmware modules). If "Module – Single" has been selected, press **Send** each time a firmware module has been programmed.
7. With successful update press **Disconnect** button.
  - The drive firmware is started.
8. Exit Dolfi.
  - Should the number of parameters to be buffered have changed, "PL" appears on the display (in case errors are pending, then clear these first). If you now press the S1 key, all buffered parameters are reset to their default values. During this time, "C8 Load default parameters" appears on the display.
  - If the "C8 Load default parameters" command has been started or the motor type replaced, "UL" appears on the display during the transition check from phase 3 to phase 4. Now press the S1 key or start the "Clear error" command. The controller default values are then loaded to the drive controller from the motor feedback data memory.
9. Load desired parameter file.

## 3 Summary FWA-DRIVE\*-SGP-20VRS-MS

### 3.1 Master Communication Interfaces

#### SERCOS Interface

---

**Note:** With the FWA-DRIVE\*-SGP-20VRS-MS firmware, the "SERCOS interface" master communication is only available with the DKC22.3/HDC01.1-A\*\*\*N-SE02 devices.

---

**General features:**

- Cyclical data exchange of command values and actual values in equal time intervals
- Data transfer by means of optic fiber
- Service channel for parameterization and diagnosis
- Configuration of the telegram contents is possible
- Synchronization between the point in time the command values become effective and the actual value measuring point in time of all the drives in a ring

**Firmware-specific features:**

- Cycle time: min. 2000  $\mu$ s, max. 65 ms, granularity 1 (i.e. multiples of 1000  $\mu$ s can be set)
- SERCOS compatibility class C
- Baud rate: optionally 2 MBaud or 4 MBaud
- Transmission power can be set
- Max. number of configurable data in the MDT: 16 byte
- Max. number of configurable data in the AT: 16 byte
- Multiplex channel with one data container for MDT data and one for AT data; indexed addressing of elements of list parameters is possible
- Freely configurable signal control word and signal status word
- Automatic baud rate detection

#### Parallel Interface (with ECODRIVE03 Only)

---

**Note:** With the FWA-DRIVE\*-SGP-20VRS-MS firmware, the "parallel interface" master communication is only available with DKC21.3. This functionality cannot be used with DURADRIVE.

---

**General features:**

- 16 digital inputs freely configurable via signal control word
- 12 digital outputs freely configurable via signal status word
- Operating modes can be switched via digital inputs of the parallel interface

## Analog Interface (with ECODRIVE03 Only)

---

**Note:** With the FWA-DRIVE\*-SGP-20VRS-MS firmware, the "analog interface" master communication is only available with DKC21.3. This functionality cannot be used with DURADRIVE.

For inputting analog command values, the general drive function "Analog inputs" (connector X3) is used (see "General Functions").

---

**General features:**

- Drive halt input
- Input for drive enable
- Ready-for-operation output

## 3.2 Basic Operating Modes

### Torque/Force Control

**Note:** With DURADRIIVE it is impossible to preset analog command values.

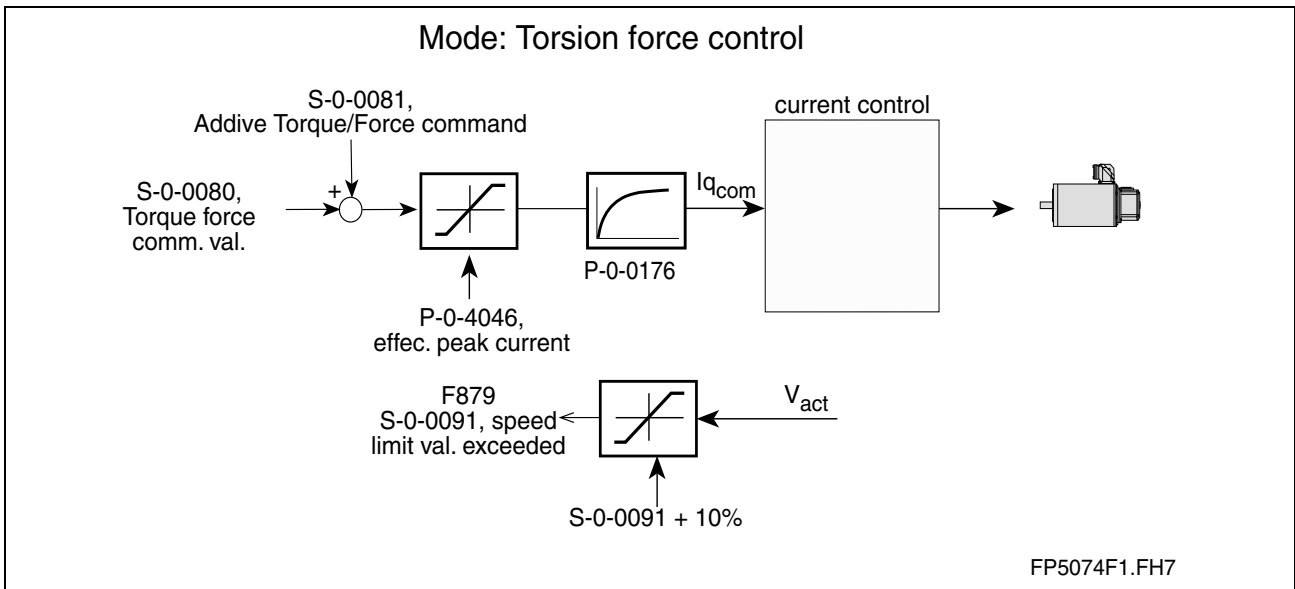

Fig. 3-1: Block diagram: torque/force control

- Torque/force control with regard to the command value preset in parameter **S-0-0080, Torque/Force command** and an additive torque command value in parameter **S-0-0081, Additive Torque/Force command**
- Limiting the preset command value to the limit value that can be parameterized
- Filtering the command value by means of parameter **P-0-0176, Torque/Force command smoothing time constant**
- Monitoring the actual velocity for exceeding parameter **S-0-0091, Bipolar velocity limit value**

## Velocity Control

**Note:** With DURADRIVE it is impossible to preset analog command values.

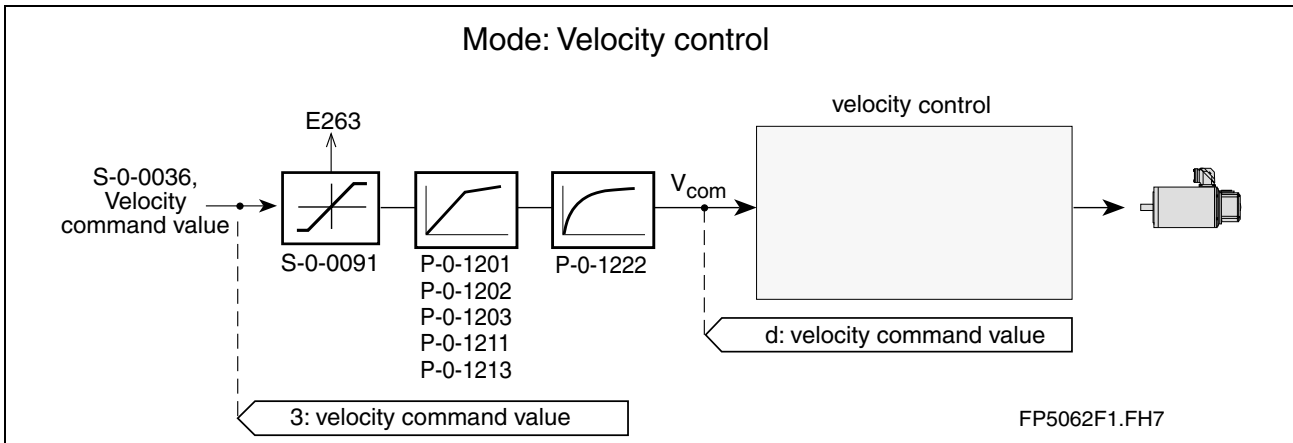

Fig. 3-2: Block diagram: velocity control

- Separately adjustable two-stage acceleration and deceleration limit of the preset velocity command value (parameter **P-0-1211, Deceleration ramp 1** and **P-0-1213, Deceleration ramp 2**); switching from ramp 1 to ramp 2 is done at selectable velocity
- Smoothing the preset command value using a low-pass filter that can be set
- Smoothing the variable using a low-pass filter that can be set
- Filtering a resonance frequency of the variable using a rejection filter with rejection frequency and bandwidth that can be set
- Limiting the variable to a limit value that can be set



## Position Control

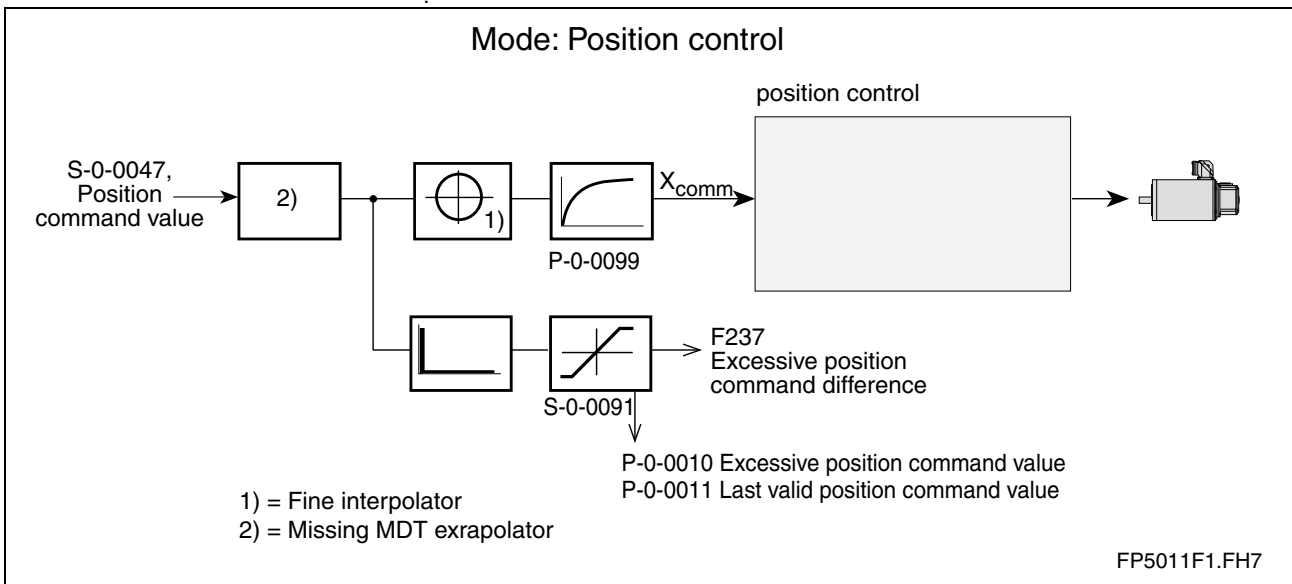

Fig. 3-3: Block diagram: position control

- Position control with regard to **S-0-0047, Position command value**
- Monitoring the position command value difference for exceeding parameter **S-0-0091, Bipolar velocity limit value**
- Fine interpolation of the command value specified in the NC cycle pulse to 1 ms
- Interpolator can be switched from linear to cubic by means of parameter **P-0-0187, Position command processing mode, bit 0** (default is linear fine interpolator)
- Smoothing the fine interpolated position command values using a low-pass filter that can be set, parameter **P-0-0099, Position command smoothing time constant**
- Position control with regard to actual position value encoder 1 (motor encoder) or actual position value encoder 2 [external (load-side) encoder]
- Dynamic synchronization when changing the operating mode

## Drive-Internal Interpolation

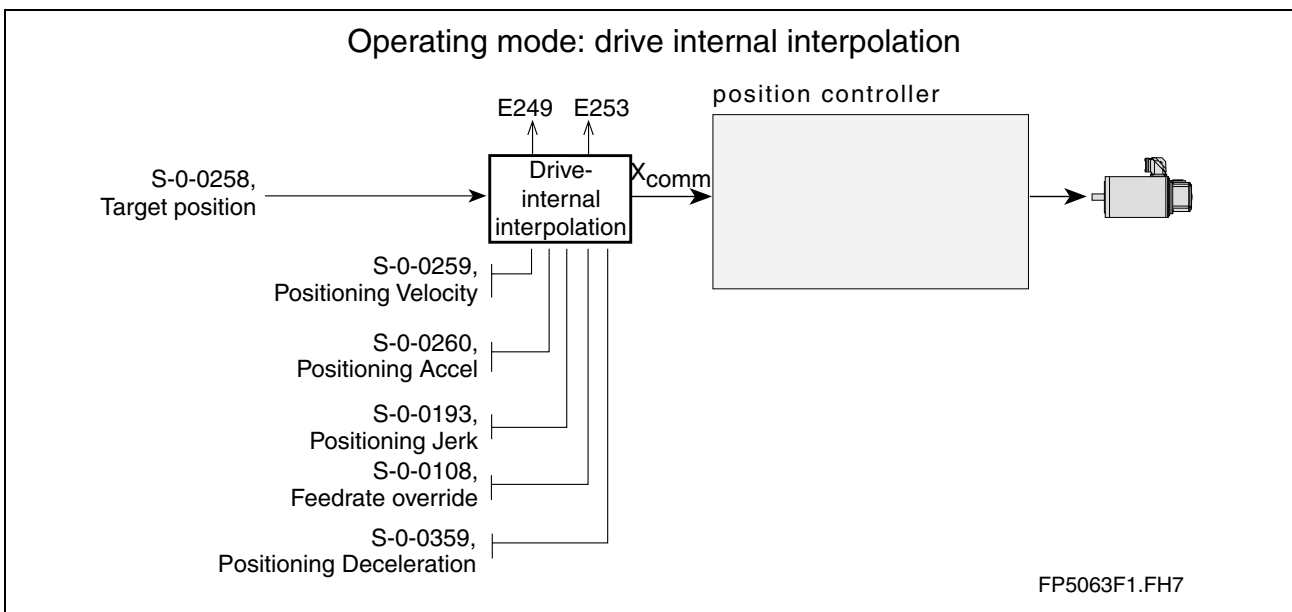

Fig. 3-4: Block diagram: drive-internal interpolation

- Drive-internal generation of a position command value profile to travel to a preset target position (S-0-0258) while maintaining the positioning velocity (S-0-0259) and positioning acceleration (S-0-0260) or positioning deceleration (S-0-0359) that can be set; can be set separately
- Jerk limitation of the generated position command value
- Evaluation of the positioning velocity with feedrate override
- Monitoring the positioning velocity for exceeding parameter **S-0-0091, Bipolar velocity limit value**
- Monitoring the target position for maintaining position limit values
- Command value mode in the modulo format can be set
- Acceleration feedforward (S-0-0348) can be set
- Position control with regard to actual position value encoder 1 (motor encoder) or actual position value encoder 2 [external (load-side) encoder]

## Drive-Controlled Positioning

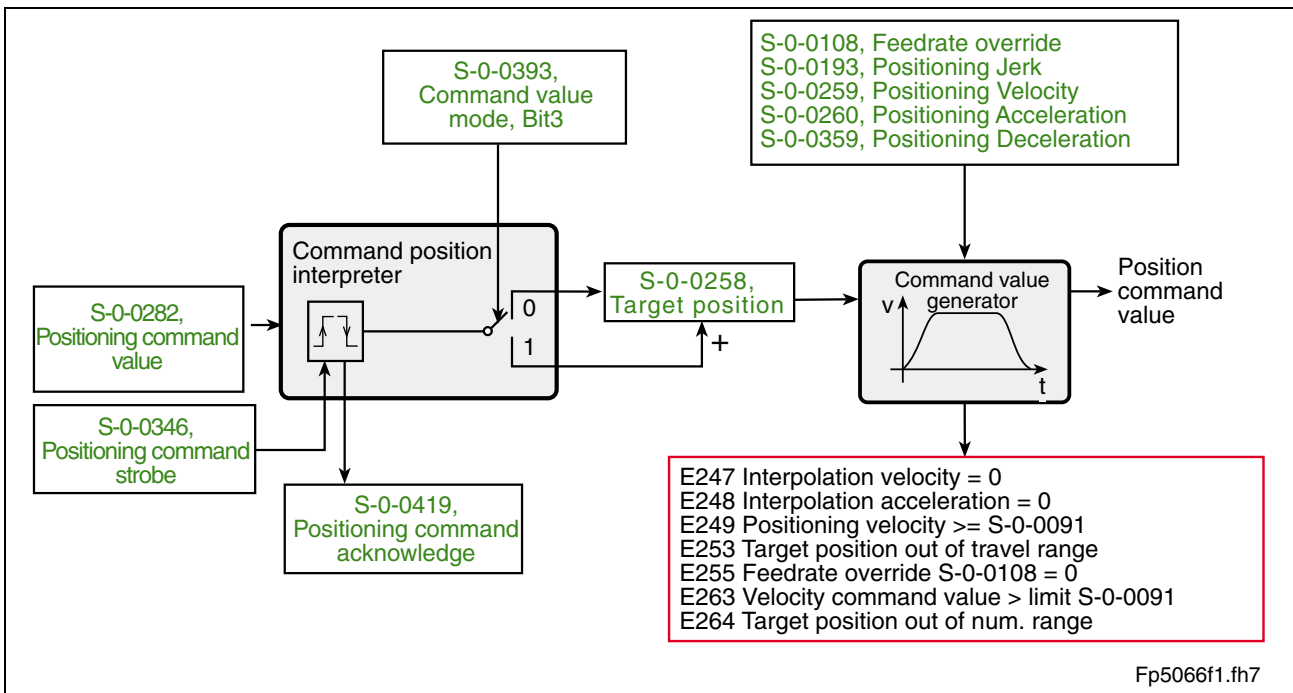

Fig. 3-5: Block diagram: drive-controlled positioning

- Drive-internal generation of a position command value profile to travel to a target position (S-0-0258) preset by means of a positioning command value (S-0-0282) while maintaining the positioning velocity (S-0-0259) and positioning acceleration (S-0-0260) or positioning deceleration (S-0-0359) that can be set; can be set separately
- Control of acceptance of the positioning command value via toggle bit (S-0-0346, bit 0)
- Jerk limitation of the generated position command value
- Evaluation of the positioning velocity with feedrate override
- Monitoring the positioning velocity for exceeding parameter **S-0-0091, Bipolar velocity limit value**
- Monitoring the target position for maintaining position limit values
- Command value mode in the modulo format can be set
- Acceleration feedforward (S-0-0348) can be set
- Position control with regard to actual position value encoder 1 (motor encoder) or actual position value encoder 2 [external (load-side) encoder]
- Generation of the target position from preset positioning command value (absolute or relative positioning)
- Acceleration and deceleration ramps can be set separately

**Note:** If the positioning command value is accepted, the drive data are written to parameter **S-0-0258, Target position**. The axis is positioned in its target position. If the control unit data are written directly to parameter **S-0-0258, Target position**, this operating mode is compatible with the operating mode "Drive-internal interpolation".

## Positioning Block Mode

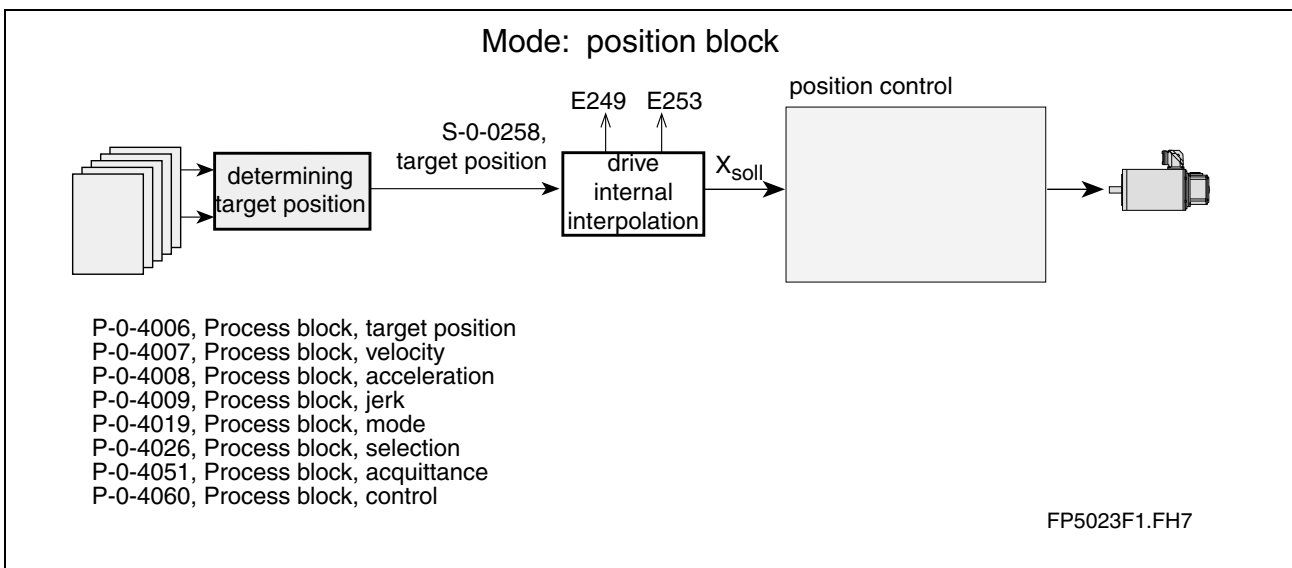

Fig. 3-6: Block diagram: positioning block mode

- Positioning block preselection via parameter **P-0-4026, Process block selection** or via digital inputs (with DKC21.3 only; impossible with DURADRIVE)
- Different modes can be set separately for each positioning block:
  - absolute
  - relative without residual path storage
  - relative with residual path storage
  - infinite travel in positive/negative direction
- Following block mode with position switching or switching signal-dependent switching
- Following block mode with position switching in modes "block transition with old positioning speed", "block transition with new positioning speed" and "block transition with intermediate stop"
- Monitoring the positioning velocity for exceeding the velocity limit value (S-0-0091)
- Monitoring the target position for maintaining position limit values
- Acceleration feedforward can be set
- Position control with regard to actual position value encoder 1 (motor encoder) or actual position value encoder 2 [external (load-side) encoder]
- Acceleration and deceleration can be parameterized separately for each process block. The maximum delay is fixed in parameter **P-0-4063, Process block deceleration**.
- For processing the next process block with block advance by a switch signal the active cam edge can be selected. The effective edge is fixed in parameter **P-0-4019, Process block mode**.
  - **bit 9** = 0: positive edge
  - **bit 9** = 1: negative edge

## Jogging

- The "Jogging" mode (positive and negative) is configured:
  - via digital inputs with DKC21.3 (impossible with DURADRIVE)
  - via parameter **P-0-4056, Jog inputs** with DKC22.3/HDC01.1-A\*\*\*N-SE02
- The drive generates the position command value profile while maintaining  
**P-0-4030, Jog velocity**,  
**S-0-0260, Positioning Acceleration**,  
**S-0-0359, Positioning Deceleration** and  
**S-0-0193, Positioning Jerk** for travelling in one direction.
- With active position limit values and a measuring system that has been homed, the drive runs to the position limit value minus the positioning window and warning **E831 Position limit reached during jog** is generated.

## Velocity Synchronization with Virtual Master Axis

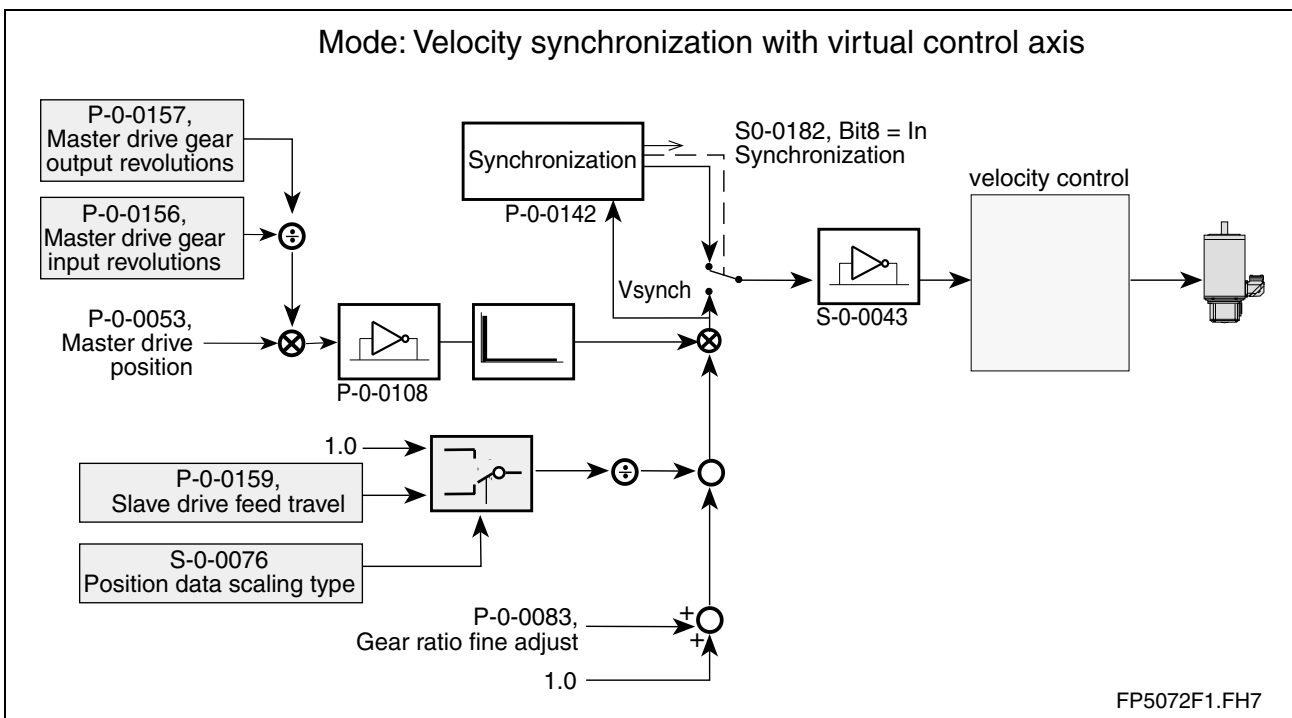

Fig. 3-7: Block diagram: velocity synchronization

- Velocity control with regard to velocity command values calculated by drive from master axis positions and the electronic gear ratio. It is possible to dynamically change the electronic gear ratio (fine adjustment) and the master axis gear (P-0-0156/P-0-0157).
- Drive-controlled acceleration with synchronization acceleration to the velocity command value when this operating mode has been activated
- Status message "IN-Synchronization" with active and non-active operating mode
- Extrapolation of master axis position with simple MDT failures
- Rotary or translatory output of electronic gearbox as dependent on the position scaling selected
- Determining the master axis position range by means of parameter **P-0-0750, Master axis revolutions per master axis cycle**
- It is possible to limit the change of the velocity command value by the synchronization acceleration

## Phase Synchronization with Virtual Master Axis

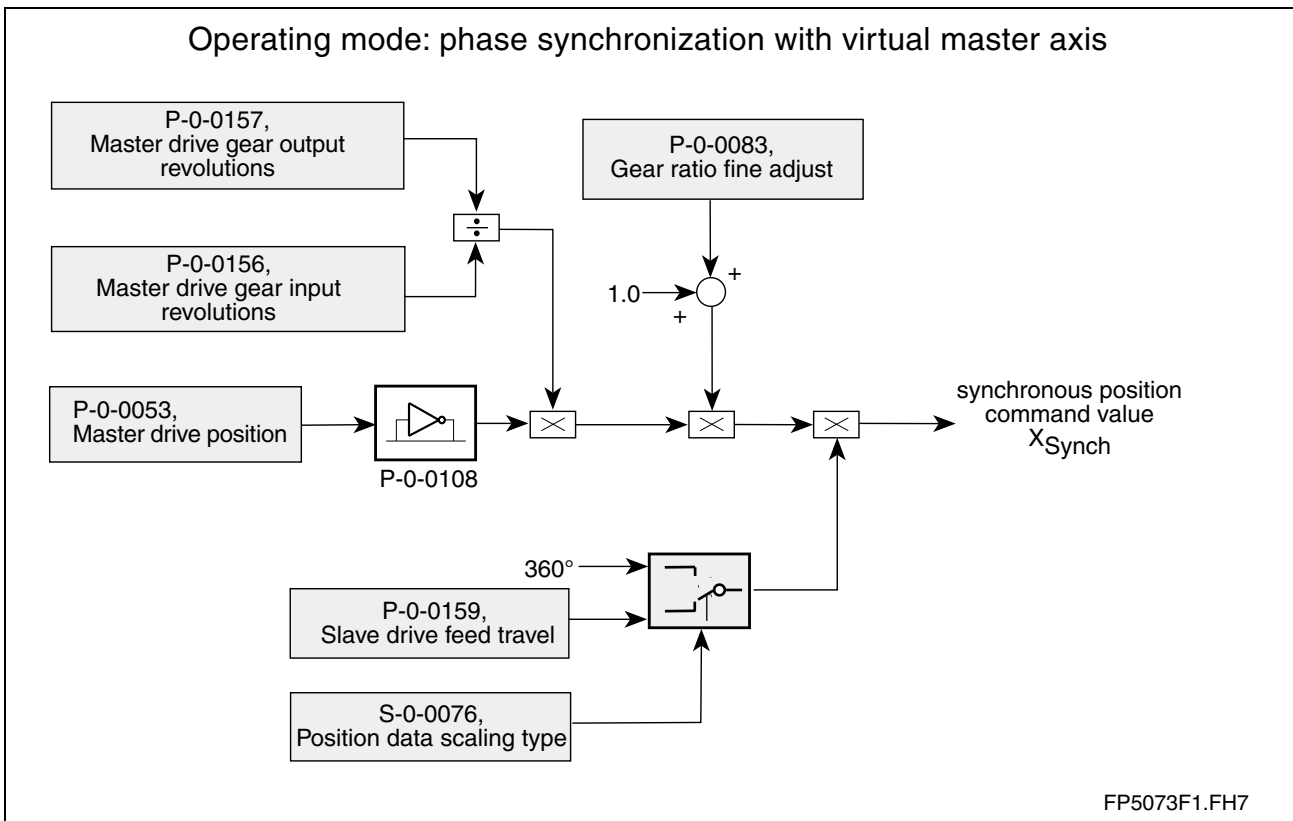

Fig. 3-8: Block diagram: phase synchronization

- Position control with regard to position command values calculated by the drive from the master axis position, the master axis gear and a gear fine adjustment. It is possible to dynamically change the master axis gear (P-0-0156/P-0-0157).
- Fine interpolation of the master axis positions specified in the NC cycle pulse
- In the "phase synchronization" mode of operation, the parameter **S-0-0103, Modulo value** is always set to a fixed value of 360° (corresponding to one load revolution).
- Determining the master axis position range by means of parameter **P-0-0750, Master axis revolutions per master axis cycle**
- Drive-controlled synchronization to the sum of the position command value plus the additive position command value with the synchronization acceleration, velocity and direction being maintained. The synchronous position command value always is a position in the command value cycle. There are various modes for synchronization:
  - Synchronization in the command value cycle
  - Synchronization in a part of the command value cycle
  - Synchronization in the modulo range
  - Status message: "Synchronization completed"

Absolute and relative synchronization is possible which also allows relative processing of parameter **S-0-0048, Position command value additional**

- Changes of parameter **S-0-0048, Position command value additional** are either smoothed using a filter or positioned by means of the synchronization acceleration and velocity
- Generation of parameter **P-0-0034, Position command additional actual value** as the difference between actual position value and calculated position command value
- Status message "IN-Synchronization" with active and non-active operating mode
- Extrapolation of master axis position with simple MDT failures
- Rotary or translatory output of electronic gearbox as dependent on the position scaling selected



## Electronic Cam Shaft with Virtual Master Axis

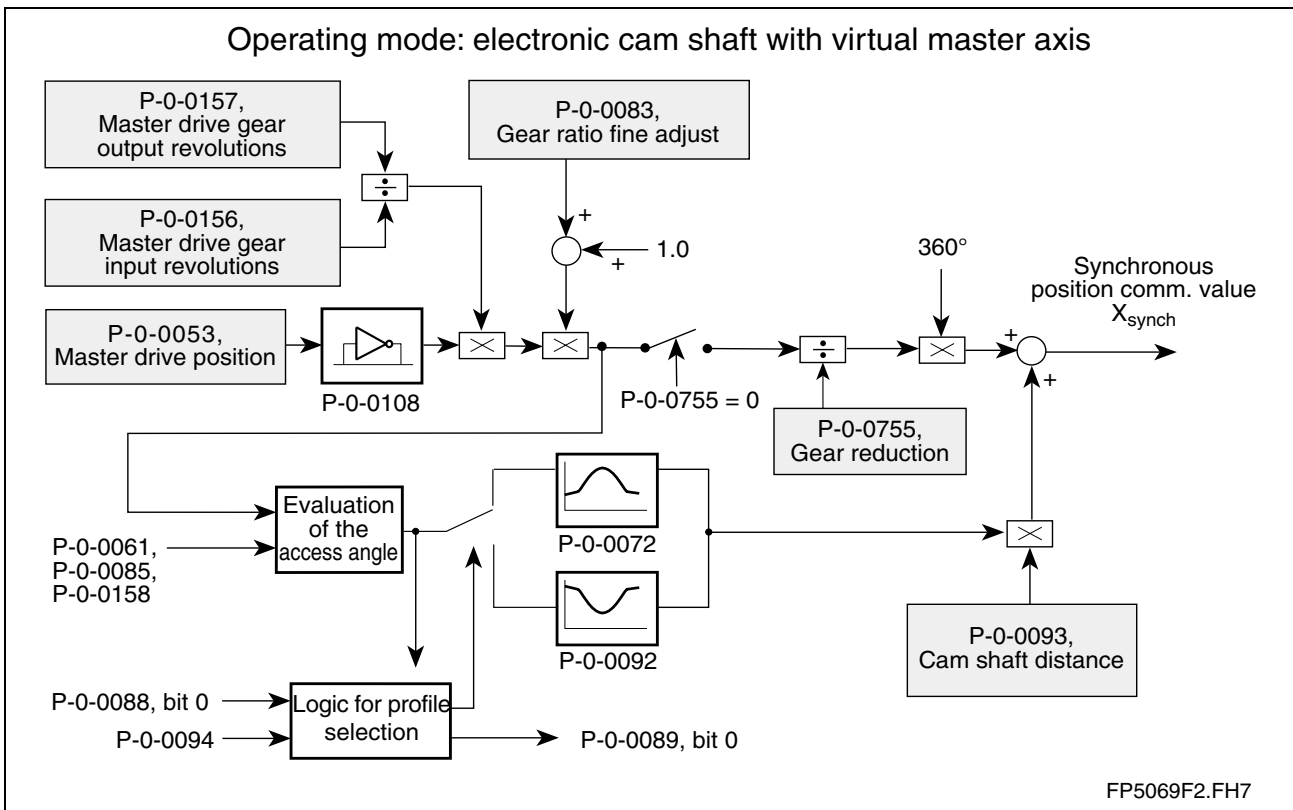

Fig. 3-9: Block diagram: electronic cam shaft

- Position control with regard to position command values calculated by the drive from the master axis position, the master axis gear, a **gear fine adjustment**, a cam shaft profile and the cam shaft distance. The master axis position as per master axis gear (P-0-0156/P-0-0157) serves as the profile access angle for the cam shaft profiles.
- In the "Electronic cam shafts" mode of operation, parameter **S-0-0103, Modulo value**, with the respective cam shaft profile, is freely selectable.
- Drive-controlled synchronization to the sum of the position command value plus the additive position command value with the synchronization acceleration, velocity and direction being maintained. The synchronous position command value always is a position in the command value cycle. There are various modes for synchronization:
  - Synchronization in the command value cycle
  - Synchronization in a part of the command value cycle
  - Synchronization in the modulo range
  - Status message: "Synchronization completed"
- Absolute and relative synchronization is possible
- Absolute and relative synchronization is possible which also allows relative processing of parameter **S-0-0048, Position command value additional**
- Change velocity can be set for **P-0-0061, Angle offset begin of profile**
- Extrapolation of master axis position with simple MDT failures

- Fine interpolation of the master axis positions specified in the NC cycle pulse
- Fine interpolation of the cam shaft profile values
- Two cam shaft profiles with possibility of switching at specified angle
- Change in cam shaft distance only becomes effective at parameterized angle
- Offset for profile access angle can be set
- Lag-error dependent advance of the profile access angle for lag error compensation can be set
- Drive-controlled synchronization to the sum of the position command value plus the additive position command value with the synchronization acceleration, velocity and direction being maintained; status message: "Synchronization completed"
- Changes of parameter **S-0-0048, Position command value additional** are either smoothed using a filter or positioned by means of the synchronization acceleration and velocity
- Generation of parameter **P-0-0034, Position command additional actual value** as the difference between actual position value and calculated position command value
- Status message "IN-Synchronization" with active and inactive operating mode
- Acceleration feedforward can be set
- Separation of constant movement and the movement resulting from the cam shaft (cross cutter function)
- It is possible to simultaneously switch the master axis gear and the distance value

## Velocity Synchronization with Real Master Axis

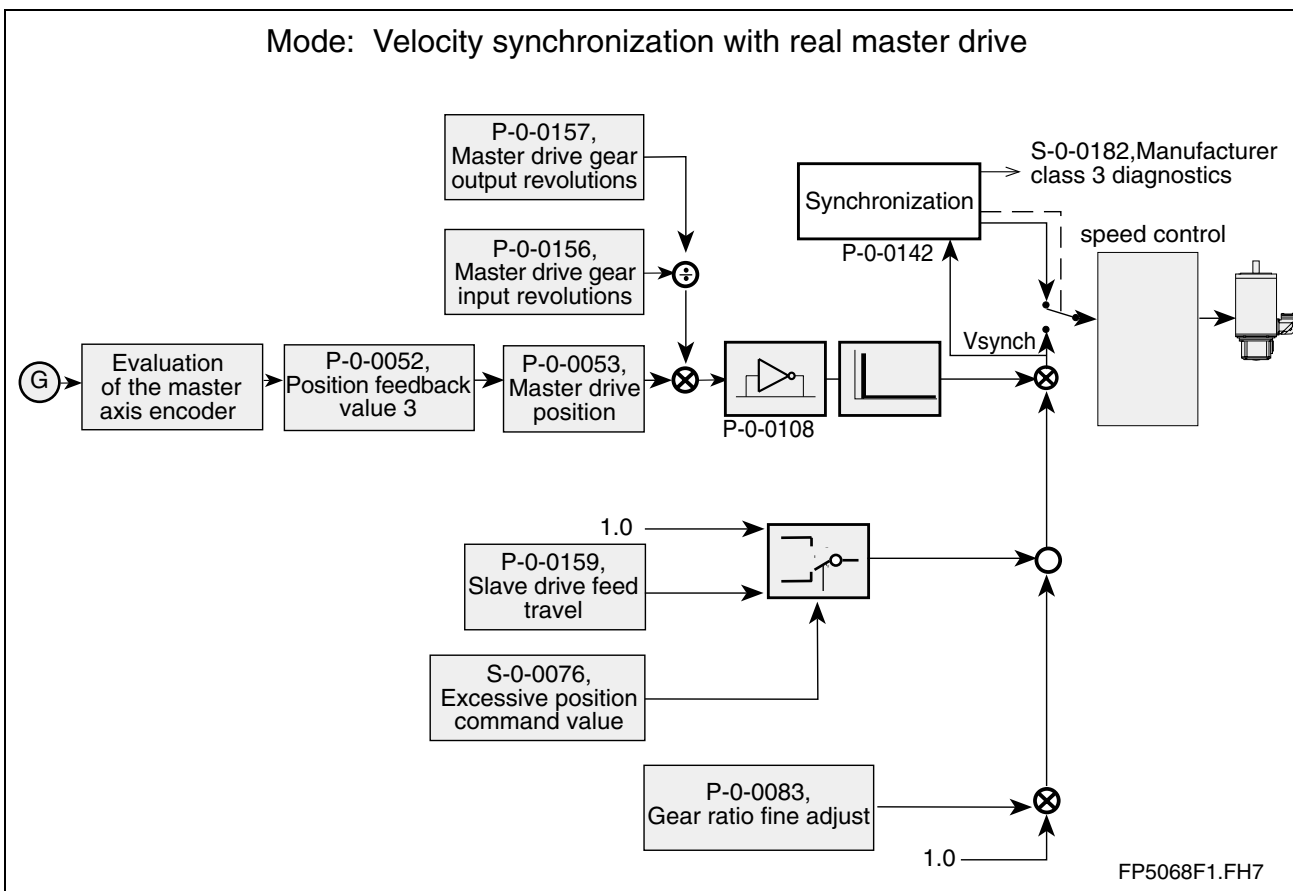

Fig. 3-10: Block diagram: velocity synchronization with real master axis

- The position of the master axis encoder (**P-0-0052, Position feedback value 3**) is directly used as the master axis command value (**P-0-0053, Master drive position**).
- Velocity control with regard to velocity command values calculated by the drive from the master axis positions, the master axis gear and a gear fine adjustment. It is possible to dynamically change the electronic gear ratio (fine adjustment) and the master axis gear (P-0-0156/P-0-0157).
- The master axis position range is determined by means of parameter **P-0-0750, Master axis revolutions per master axis cycle**. The master axis encoder range must equal parameter **P-0-0750, Master axis revolutions per master axis cycle**.
- Drive-controlled acceleration with synchronization acceleration to the velocity command value when this operating mode has been activated
- Optional limitation of the maximum command velocity change to the value of the synchronization acceleration
- Status message "IN-Synchronization" with active and inactive operating mode
- Rotary or translatory output of electronic gearbox as dependent on the position scaling selected

**Notes on master axis encoder evaluation:**

- Setting absolute measurement for master axis encoder

The "Set absolute measurement" command can also be applied to the master axis encoder. Parameter **S-0-0147, Homing parameter** determines the encoder to be set. Parameter **S-0-0054, Reference distance 2** determines the reference value of the master axis encoder.

- Range of the master axis encoder

The modulo range of the master axis encoder can be expanded to  $n * 2^{20}$  revolutions. The value is defined in parameter **P-0-0765, Range of master encoder**.

- Absolute value monitoring of the master axis encoder

On switching to the operating mode (phase 4) the position of the master axis encoder is checked. If this position differs by more than the value defined in parameter **P-0-0766, Master encoder, monitoring window**, the error **F276 Absolute encoder out of allowed window** will be generated.

- Filtering the actual position value 3

For filtering the actual position value 3 a moving average filter with time constants of 0, 2, 4 and 8 ms is available. The phase shift caused by averaging is compensated.

## Phase Synchronization with Real Master Axis

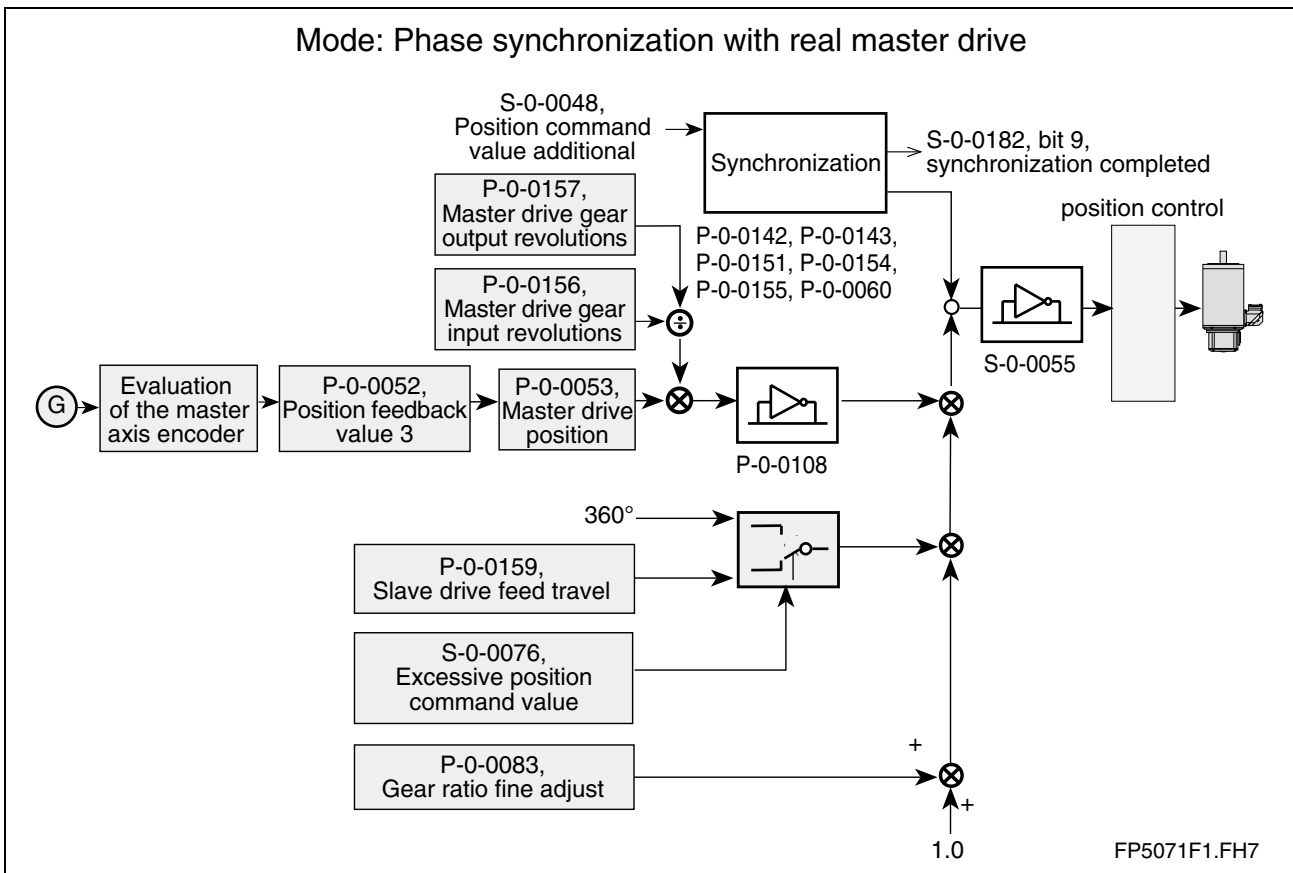

Fig. 3-11: Block diagram: phase synchronization with real master axis

- The position of the master axis encoder (**P-0-0052, Position feedback value 3**) is directly used as the master axis command value (**P-0-0053, Master drive position**).
- Compensation of the filter run time and the processing dead time
- Position control with regard to position command values calculated by the drive from the master axis position, the master axis gear, a gear fine adjustment and the electronic gear ratio. It is possible to dynamically change the master axis gear (P-0-0156/P-0-0157).
- The master axis position range is determined by means of parameter **P-0-0750, Master axis revolutions per master axis cycle**. The master axis encoder range must equal the parameter containing the number of master axis revolutions per master axis cycle
- Drive-controlled synchronization to the sum of the position command value plus the additive position command value with the synchronization acceleration, velocity and direction being maintained. The synchronous position command value always is a position in the command value cycle. There are various modes for synchronization:
  - Synchronization in the command value cycle
  - Synchronization in a part of the command value cycle
  - Synchronization in the modulo range
  - Status message: "Synchronization completed"

- Absolute and relative synchronization is possible which also allows relative processing of parameter **S-0-0048, Position command value additional**
- Changes of parameter **S-0-0048, Position command value additional** are either smoothed using a filter or positioned by means of the synchronization acceleration and velocity
- Generation of parameter **P-0-0034, Position command additional actual value** as the difference between actual position value and calculated position command value
- Status message "IN-Synchronization" with active and non-active operating mode
- Rotary or translatory output of electronic gearbox as dependent on the position scaling selected

#### Notes on master axis encoder evaluation:

- Setting absolute measurement for master axis encoder

The "Set absolute measurement" command can also be applied to the master axis encoder. Parameter **S-0-0147, Homing parameter** determines the encoder to be set. Parameter **S-0-0054, Reference distance 2** determines the reference value of the master axis encoder.

- Range of the master axis encoder

The modulo range of the master axis encoder can be expanded to  $n * 2^{20}$  revolutions. The value is defined in parameter **P-0-0765, Range of master encoder**.

- Absolute value monitoring of the master axis encoder

On switching to the operating mode (phase 4) the position of the master axis encoder is checked. If this position differs by more than the value defined in parameter **P-0-0766, Master encoder, monitoring window**, the error **F276 Absolute encoder out of allowed window** will be generated.

- Filtering the actual position value 3

For filtering the actual position value 3 a moving average filter with the time constants 0, 2, 4 and 8 ms is available. The phase shift caused by averaging is compensated.

## Electronic Cam Shaft with Real Master Axis

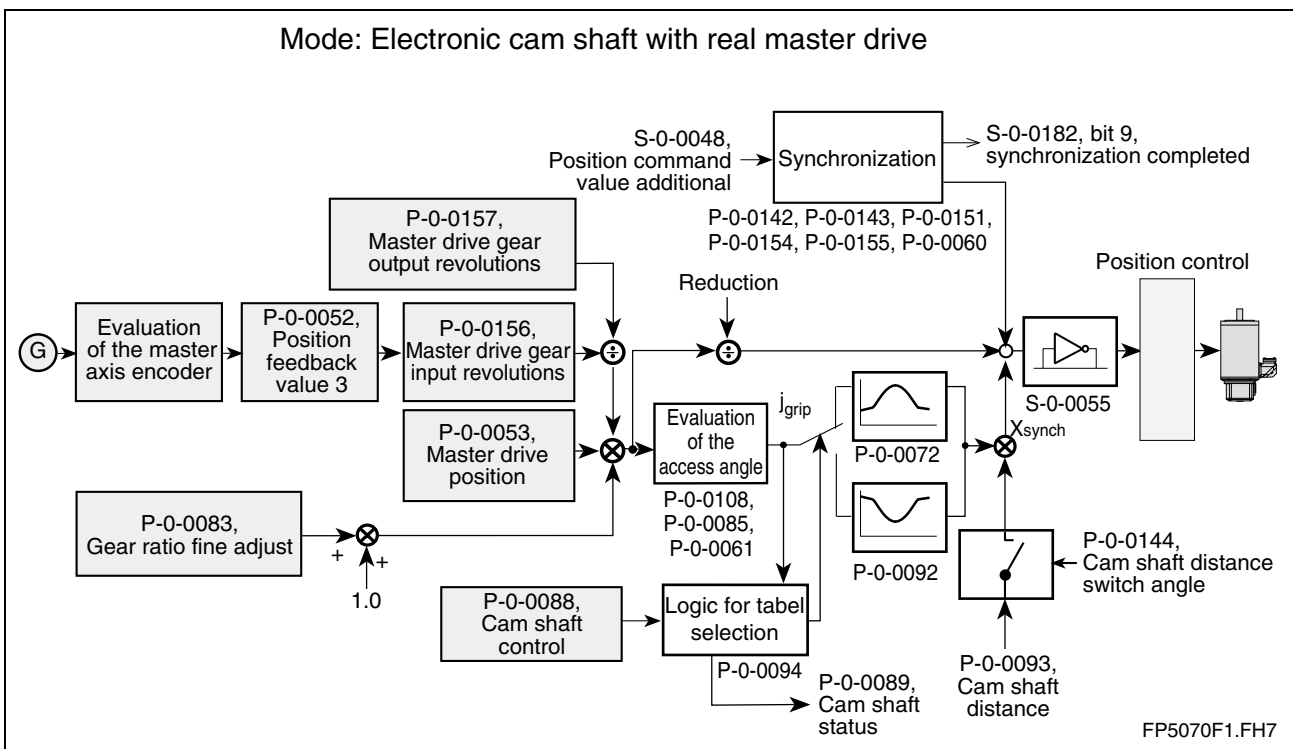

Fig. 3-12: Block diagram: electronic cam shaft with real master axis

- The position of the master axis encoder (**P-0-0052, Position feedback value 3**) is directly used as the master axis command value (**P-0-0053, Master drive position**).
- Compensation of the filter run time and the processing dead time
- Position control with regard to position command values calculated by the drive from the master axis position, the master axis gear, a gear fine adjustment, a cam shaft profile and the cam shaft distance. The master axis position as per master axis gear (P-0-0156/P-0-0157) serves as the profile access angle for the cam shaft profiles.
- The master axis position range is determined by means of parameter **P-0-0750, Master axis revolutions per master axis cycle**. The master axis encoder range must equal parameter **P-0-0750, Master axis revolutions per master axis cycle**.
- Drive-controlled synchronization to the sum of the position command value plus the additive position command value with the synchronization acceleration, velocity and direction being maintained. Status message: "Synchronization completed". The synchronous position command value always is a position in the command value cycle. There are various modes for synchronization:
  - Synchronization in the command value cycle
  - Synchronization in a part of the command value cycle
  - Synchronization in the modulo range
  - Status message: "Synchronization completed"
- Absolute and relative synchronization is possible
- Change velocity can be set for **P-0-0061, Angle offset begin of profile**
- Fine interpolation of the cam shaft profile values

- Two cam shaft profiles with possibility of switching at specified angle
- Change in cam shaft distance only becomes effective at parameterized angle
- Offset for profile access angle can be set
- Lag-error dependent advance of the profile access angle for lag error compensation can be set
- Changes of parameter **S-0-0048, Position command value additional** are either smoothed using a filter or positioned by means of the synchronization acceleration and velocity
- Generation of the position command additional actual value as the difference between actual position value and calculated position command value
- Status message "IN-Synchronization" with active and non-active operating mode
- Acceleration feedforward can be set
- Separation of constant movement and the movement resulting from the cam shaft (cross cutter function)
- It is possible to simultaneously switch the master axis gear and the distance value

#### Notes on master axis encoder evaluation:

- Setting absolute measurement for master axis encoder

The "Set absolute measurement" command can also be applied to the master axis encoder. Parameter **S-0-0147, Homing parameter** determines the encoder to be set. Parameter **S-0-0054, Reference distance 2** determines the reference value of the master axis encoder.

- Range of the master axis encoder

The modulo range of the master axis encoder can be expanded to  $n \cdot 2^{20}$  revolutions. The value is defined in parameter **P-0-0765, Range of master encoder**.

- Absolute value monitoring of the master axis encoder

On switching to the operating mode (phase 4) the position of the master axis encoder is checked. If this position differs by more than the value defined in parameter **P-0-0766, Master encoder, monitoring window**, the error **F276 Absolute encoder out of allowed window** will be generated.

- Filtering the actual position value 3

For filtering the actual position value 3 a moving average filter with the time constants 0, 2, 4 and 8 ms is available. The phase shift caused by averaging is compensated.



### 3.3 Controller Structure

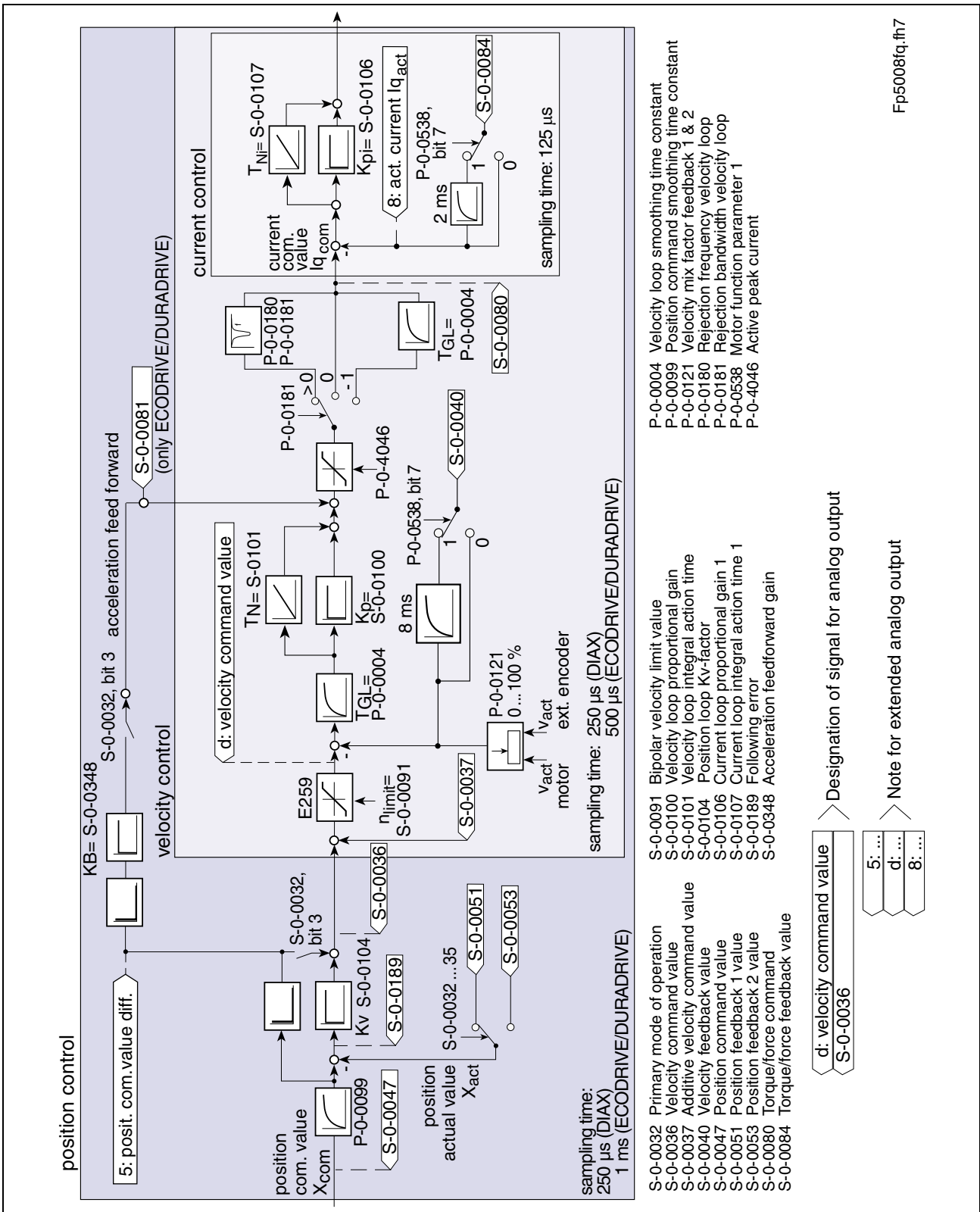

Fig. 3-13: Controller structure FWA-DRIVE\*-SGP-20VRS

**Note:** The controller parameters can be set either manually or by an automated motion cycle (parameter **P-0-0162**, **D900 Command Automatic control loop adjust**).

## 3.4 Motor Types

The following motor types can be operated with the firmware:

- MKD
  - 2AD
  - 1MB
  - LAF
  - MKE
  - MBS (rotary synchronous kit motor)
  - MHD
  - ADF
  - MBW
  - LAR
  - LSF (linear synchronous kit motor)
- Motor encoder on load side with rotary asynchronous motors
  - Field weakening also with synchronous motors
  - Automatic commutation setting with synchronous motors with incremental motor measuring systems after initial switching on of drive enable after switching into operating mode; correction of the commutation offset when overrunning the reference mark (only incremental measuring systems) with parameter **P-0-0507, Optimized commutation offset**
  - Standstill or nominal current standardized to cooling type; new parameter **P-0-0640, Cooling type**
  - Support of third-party motors with temperature sensor KTY84

## Motor Holding Brake

### Features:

- Self-holding and self-releasing brake
- Brake delay time can be set
- Servo and main spindle brake can be selected
- Brake can be released by the user via parameter **P-0-0542, B100 Command Release motor holding brake**
- Holding brake monitor: "brake check" command via command start or automatically after drive enable applied
- Parameter **P-0-0539, Brake status** allows digital brake activation

## 3.5 Measuring Systems

### Motor Encoder

**Note:** As standard, the motor encoders are already mounted at delivery of the motors. The motor encoder type can only be selected with kit motors.

The following motor encoders are supported:

P-0-0074	Interface connector	Measuring system
1	X4	digital servo feedback or resolver
2	X8	incremental encoder with 1V sine signals (from Heidenhain)
5	X8	incremental encoder with square-wave signals (from Heidenhain)
8	X8	encoder with EnDat interface
9	X8	gearwheel encoder with 1V <sub>pp</sub> signals
10	X4	resolver encoder without feedback data memory
11	X4+X8	resolver without feedback data memory + incremental encoder with sine signals
12	X4+X8	Hall encoder + square-wave encoder
14	X4+X8	Hall encoder + sine encoder

Fig. 3-14: Measuring systems: connectors

### Optional Measuring System

Evaluation as second load-side control encoder or load-side motor encoder is possible (depends on P-0-0185):

P-0-0185	Functions of encoder 2
0	optional control encoder
1	master axis encoder
2	load-side motor encoder
3	measuring wheel encoder
5	relative master axis encoder

Fig. 3-15: Functions of encoder 2

P-0-0075	Interface connector	Measuring system
1	X4	digital servo feedback
2	X8	incremental encoder with 1V sine signals (signal specification of Heidenhain)
5	X8	incremental encoder with square-wave signals (signal specification of Heidenhain)
8	X8	encoder with EnDat interface
9	X8	gearwheel encoder with 1V <sub>pp</sub> signals

Fig. 3-16: Measuring systems: connectors

- Can be evaluated as an absolute measuring system
- Monitoring of the actual position value of the external encoder for plausibility in terms of the actual position value of the motor encoder

### Optional Encoder as Master Axis Encoder

The following real master axis encoders can be evaluated:

Type	P-0-0075, Feedback 2 type	Note
GDS/GDM	1	cyclically absolute
Measuring system from Heidenhain with EnDat interface	8	cyclically absolute
incremental encoder with 1V sine signals (signal specification of Heidenhain)	2	incremental
incremental encoder with TTL signals	5	incremental

#### Absolute master axis encoder

Parameter **P-0-0765, Range of master encoder** determines the absolute range of the master axis encoder. The parameter **P-0-0765, Range of master encoder** contains a factor of  $2^{20}$  so that the following is applicable:

- Modulo range of the master axis encoder = master axis encoder range  $\times 2^{20}$
- The master axis encoder is evaluated/displayed in this range.

The absolute (see below) master axis encoder is set by means of parameter **P-0-0012, C300 Command Set absolute measurement**. The position of the master axis encoder (**P-0-0052, Position feedback value 3**) is set to the value of the parameter **S-0-0054, Reference distance 2**.

#### Incremental master axis encoder

Incremental encoders can also be used as master axis encoders. Depending on the parameter **P-0-0185, Function of encoder 2**, incremental encoders are evaluated incrementally only or, after the zero pulse of the encoder has been detected, absolutely within one revolution.

The actual position value 3 can be offset using the parameter **P-0-0087, Offset position feedback value 3**. The actual position value 3 can be smoothed by means of moving average filter with compensation of the filter runtime. Parameter **P-0-0186, Position feedback value 3, smoothing time** determines the time constant.

Only binary resolutions can be used as a master axis encoder!

## Absolute Measuring Systems

Absolute measuring systems are those encoders with an absolute range of at least one encoder revolution. This includes the measuring systems:

- Single-/multi-turn HSF
- Single-/multi-turn resolver
- Single-/multi-turn encoder with EnDat interface
- Absolute linear scales with EnDat interface

These measuring systems are only treated as absolute encoders, if their **absolute range exceeds or equals half the travel range or the entire travel range**.

The absolute encoder function can be switched off.

If position data are displayed in modulo format, it is possible to evaluate both motor and optional encoder as absolute encoders. Absolute encoder monitoring is also possible in both cases.

## Establishing the Position Reference for Actual Values

It is possible to evaluate single-turn encoders and multi-turn encoders as absolute or non-absolute measuring systems. To be selected in the relevant "position encoder type" parameter.

Depending on the selection, the position reference is established by means of parameter **P-0-0012, C300 Command Set absolute measurement** or by means of parameter **S-0-0148, C600 Drive controlled homing procedure command**.

- **C300 Command Set absolute measurement:**

- Initializing the actual position value of an absolute measuring system with regard to a preset value related to the machine zero point, with the help of an **initiator** (switch cam)
- Initializing the actual position value of an absolute measuring system with regard to a preset value related to the machine zero point, with the help of a **command**
- Executing the command either for the actual position value of the motor encoder or the external encoder
- Setting absolute measurement without drive enable
- Setting absolute measurement with drive enable followed by "Drive-controlled homing"
- Setting absolute measurement with drive enable followed by deactivation of drive enable
- Absolute measurement can be set via the home switch input (for systems with slip)
- Setting absolute measurement for a master axis encoder

- **C600 Drive controlled homing procedure command:**

- While maintaining a reference velocity and acceleration to be parameterized, the drive generates position command values in order to automatically execute a drive motion which is intended to establish a reference for the actual position value with regard to the machine zero point.
- Executing the command either for the actual position value of the motor encoder or the external encoder
- Executing command with evaluation of a reference mark and/or a home switch or switching the actual position value without axis motion
- Executing the command with selectable travel direction to reference point
- Evaluation of encoders with distance-coded reference marks is possible

## 3.6 Physical Values Display Formats

- Freely definable LSB valence for the following data transmitted between drive and control unit:
  - position data: degrees, mm, inch
  - velocity data: r.p.m., m/min, inch/min, r/s, m/s, inch/s
  - acceleration data: rad/s<sup>2</sup>, m/s<sup>2</sup>, inch/s<sup>2</sup>
- Choice of data reference to motor shaft or load
- Choice between translatory and rotary scaling
- Choice between preferred scaling and parameter scaling
- Parameterizable divisor for the modulo value that can be used with "Spindle positioning"

## 3.7 Error Reactions

- **Variable error reaction** as dependent on error class and selected best possible deceleration
- Selectable settings for **best possible deceleration**:
  - velocity command value reset
  - torque command value reset
  - velocity command value to zero with command value ramp and filter
  - Additional error reactions by means of DISC drive macros; these allow, for example, absolute or relative return motion.
- **Power off on error** can be set  
If the setting "no power off on error" has been selected, the BB1 contact is closed immediately after control voltage is switched on.
- Deceleration of the drive via an emergency stop input (**E-Stop**) with drive reaction to be selected:
  - emergency stop as drive error with error class "non-fatal"
  - emergency stop as drive error with error class "travel range"
  - emergency stop as fatal warning

## 3.8 General Functions

### Comprehensive Diagnostic System

- Diagnosis parameter in plain text, as diagnosis number and as error number
- List of diagnosis numbers
- Hard wired collective messages
- Freely configurable signal status word
- Error memory with operating hours counter to store the drive errors that occurred

### Parameterization

- Basic parameter set can be activated for defined setting of the drive parameters to default values
- Customer password protection; selection of password-protected parameters can be set

## Language Selection

By means of parameter **S-0-0265, Language selection**, you can select the language of parameter names and units, as well as diagnostic texts.

The following languages have been implemented:

German  
English  
French  
Spanish  
Italian

## Drive Halt

The drive stops automatically, considering acceleration and jerk limit values.

The following limit values are used:

Previous operating state	Parameters used
no position control operating mode	P-0-1211, Deceleration ramp 1 P-0-1213, Deceleration ramp 2 P-0-1202, Final speed of ramp 1
position control with drive-internal interpolation (positioning block mode, drive-internal interpolation, drive-controlled positioning)	previous <b>positioning deceleration</b> and jerk limits remain active
position control without drive-internal interpolation	S-0-0138, Bipolar acceleration limit value S-0-0349, Jerk limit bipolar

Fig. 3-17: Acceleration and jerk with "Drive halt"

## Analog Inputs

- 2 channels with maximum input voltage range of  $\pm 10$  V
- 12-bit A/D converter
- Input of drive parameter data via scaling that can be set

## Analog Output

- 2 channels with maximum output voltage range of  $\pm 10$  V
- 8-bit D/A converter
- Output of drive parameter data via scaling that can be set
- Pre-set drive-internal signals and any bits and bytes of data memory can be output

## Oscilloscope Function

- 2 channels with 512 values each
- Preset signals can be used
- Time resolution: 500  $\mu$ s to 100 ms (time pattern: 500  $\mu$ s)
- Trigger threshold that can be set for position, velocity and torque/force data
- Drive-internal signals can be triggered and recorded
- **Extension of measuring signals to be selected (e.g. S-0-0036, P-0-0053, ...)**

## Probe Function

- 2 probe inputs with a resolution of 1  $\mu$ s
- Possible measuring signals:
  - actual position value encoder 1 or actual position value encoder 2 (if external encoder available)
  - master axis position or actual position value 3 (master axis encoder evaluation)
  - relative internal time (internal counter) with a resolution of 1  $\mu$ s and a recording width of 32 bit
- Determining measured value differences
- Measured value signals can be triggered with regard to positive or negative edges
- Expectation window for probe inputs: It is possible to define a range within which probe edges are generally accepted.
- Continuous measurement: After a measurement, the edge evaluation of the probes is automatically activated again.
- To detect any overflow during the progressing measurement, a probe counter is included in bit 8 to 15 of the corresponding "Probe latched" parameter. This counter is incremented whenever a probe is detected. If the maximum value of  $2^8-1$  (255) is reached, the counter flows over and is reset to 0!
- Failure monitor for probe events: If there does not occur any probe event within the expectation window specified, the counter is incremented in the parameter **P-0-0224, Probe, number of marker failures**. The counter is cleared as soon as a probe event occurs within the expectation window.
- The measuring signal is selected by entering the ID number of the signal in parameter **P-0-0200, Signal select probe 1** or parameter **P-0-0201, Signal select probe 2**. The parameter **P-0-0225, Probe, IDN list signal selection** lists specifies the ID numbers of the possible probe signals.
- Extended control parameter to activate expectation windows, failure monitoring function and time measurement:
- The probe event can be limited to a predefined position window. The "Probe with expectation window" function is activated in parameter **P-0-0226, Probe, extended control word**.
- In conjunction with the expectation window it is also possible to monitor the failure of a probe event. This "Mark failure monitoring function" can also be activated in parameter **P-0-0226, Probe, extended control word**.
- The time measurement for probe 1 is switched on via parameter **P-0-0226, Probe, extended control word**, too. For probe 2 there isn't any time measurement function.
- The following parameters were reprogrammed and now are 16-bit counters:
  - **S-0-0409, Probe 1 positive latched**
  - **S-0-0410, Probe 1 negative latched**
  - **S-0-0411, Probe 2 positive latched**
  - **S-0-0412, Probe 2 negative latched**
- During continuous measurement the counter value is increased with every valid probe event.



## Detecting the Marker Position

Parameter **P-0-0014, D500 Command** determine marker position allows

- checking the faultless detection of the reference mark of an incremental measuring system or
- determining the position of the reference mark in case the homing procedure is carried out by the control unit. In this case this information is used to switch the coordinate system in the control unit.

The home switch is not evaluated in this parameter.

## Measuring Wheel Mode

The measuring wheel mode feature is used with material feed axes (e. g. in sheet-metal machining). By means of a measuring wheel encoder mounted to the material, highly precise material machining is ensured even if some slip occurs between the driving motor and the material itself.

In parameter **S-0-0386, Active Position value** it is always the active actual position value that is displayed; i.e. when the "Measuring wheel mode" command is active and the drive is in a position-controlled operating mode, the actual position value 2 is provided in parameter S-0-0386 (otherwise actual position value 1).

The position difference monitor is activated with parameter **S-0-0391, Monitoring window feedback 2**. If the position difference monitor has been activated (S-0-0391 unequal zero), the position difference is cleared after every measuring wheel revolution (or after 500 mm in the case of linear scaling).

When using a measuring wheel encoder the monitoring window is to be set to the slip that is allowed per measuring wheel revolution. In the case of rotary scaling, the parameter **S-0-0391, Monitoring window feedback 2** refers to the measuring wheel circumference, in the case of linear scaling it refers to 500 mm.

## Parking Axis

The parameter **S-0-0139, D700 Command Parking axis** allows uncoupling an axis. This may, for example, be necessary if an axis is temporarily brought to a standstill. The start of this command causes all monitoring functions of the measuring system and of the control loops to be switched off.

The command may only be started without drive enable. If the command is activated with drive enable applied, then the drive generates a command error.

After starting the command

- the measuring system monitors,
- the control loop monitors and
- the temperature monitors

are deactivated.

The measuring system initializations are conducted at the end of the command. This means all initializations as with command **S-0-0128, C200 Communication phase 4 transition check** are conducted. The 7-segment display reads "PA".

This drive no longer accepts the drive enable.

## Backup Working Memory Procedure

By means of parameter **S-0-0264, B300 Backup working memory procedure command**, all cyclically configured data can be stored in the NOVRAM if required (all data that are not cyclically configured are already stored in the NOVRAM during the writing process).

## Programmable Limit Switch

- 16 dynamic position switch points with one switch-on and switch-off position each
- Parameterizable lead time for each position switch point
- Effective direction of the threshold position switch that can be parameterized, i.e. the threshold position switch only takes effect with the corresponding velocity of the selected reference value.
- Reference position:
  - **S-0-0051, Position feedback 1 value**
  - **S-0-0053, Position feedback 2 value**
  - **P-0-0053, Master drive position**
  - **P-0-0052, Position feedback value 3**
  - **P-0-0434, Internal Position command value**
- Correlation in the "DriveTop" commissioning software with positioning block target positions

## Incremental Encoder Emulation (TTL format)

- **S-0-0051, Position feedback 1 value,**
- **S-0-0053, Position feedback 2 value,**
- **P-0-0434, Internal Position command value,**
- **P-0-0053, Master drive position and P-0-0052, Position feedback value 3**

can be emulated.

The number of lines in the case of emulation can be set as follows:

<b>S-0-0076, Position data scaling type</b>	<b>Unit of parameter P-0-0502, Encoder emulation, resolution</b>
rotary position scaling	lines/encoder revolution
linear position scaling	lines/mm or lines/inch

Fig. 3-18: Setting of the number of lines with incremental encoder emulation

- Zero pulse output also with linear motors and relative encoders (if homed)
- Number of lines with emulation of master axis position can be set in lines/master axis revolution
- Zero pulse can be offset by writing data to parameter **P-0-0503, Marker pulse offset**
- Dead time compensation

## Absolute Encoder Emulation (SSI format)

- S-0-0051, Position feedback 1 value,
- S-0-0053, Position feedback 2 value,
- P-0-0434, Internal Position command value,
- P-0-0053, Master drive position and P-0-0052, Position feedback value 3

can be emulated.

The number of lines in the case of emulation can be set as follows:

Motor	Unit of parameter P-0-0502, Encoder emulation, resolution
rotary motor	bits/motor revolution
linear motor	bits/mm or bits/inch

Fig. 3-19: Setting of the number of lines with absolute encoder emulation

- With the emulation of the values displayed in the parameters S-0-0051, S-0-0053 and S-0-0047, also the emulated actual position values are offset by parameter **P-0-0012, C300 Command Set absolute measurement**.
- Possible display range: 0 to 4096 revolutions

## Automatic Controller Setting

By means of parameter **P-0-0162, D900 Command Automatic control loop adjust**, the velocity and position control loop can be set automatically.

By inputting a travel distance, the command can also be used for modulo axes.

## Automatic Commutation Setting

When the controller enable signal is switched on, **P-0-0508, Commutation offset** is determined by means of the automatic commutation setting. With this parameter it is possible to move the drive. When the command **S-0-0148, C600 Drive controlled homing procedure command** is started, the drive moves to the reference point of the machine. When passing the reference mark of the encoder, the drive switches to the value defined in parameter **P-0-0507, Optimized commutation offset**.

The value of parameter **P-0-0507, Optimized commutation offset** has to be determined with the initial commissioning procedure.

## Digital Inputs/Outputs

In conjunction with the EMD modules it is possible to evaluate freely configurable digital inputs and outputs. The assignment of the inputs to parameters is realized with parameter **P-0-0125, Assignment digital input -> IDN**. Parameters are assigned to outputs by parameter **P-0-0124, Assignment IDN -> Digital output**.

## Master Axis of Master Axis Encoder

**Operating mode:** Synchronous operating mode with "real master axis"

**Functional principle:**

The master axis position of the slave axis is generated with the actual position value 3 as the command value. The master axis generator is not required for this purpose.

If several drives, which realize the master axis connection via EcoX, follow a real master axis encoder, the master axis generator has to be activated in the master drive.

**Pertinent parameters:**

- **P-0-0052, Position feedback value 3**
- **P-0-0761, Master axis position for slave axis**
- **P-0-0762, Master axis generator, signal selection list**
- **P-0-0763, Master axis generator, signal selection list**
- **P-0-0768, Master axis generator, status**

Parameter **P-0-0052, Position feedback value 3** has to be configured in parameter **P-0-0763, Master axis generator, signal selection**.

The master axis generator generates **P-0-0761, Master axis position for slave axis** from the actual position value 3, plus a linear set-up time to compensate for the EcoX transmission time.

**P-0-0761, Master axis position for slave axis** has a fixed resolution of  $2^{20}$  increments per revolution. The modulo value is determined by the useable range of the master axis encoder.

## Master Axis of Master Drive

**Operating mode:** Any in the master; synchronous operating mode with "real master axis" in the slaves

**Functional principle:**

The master axis position of the slave axis is generated with the position command value, the actual position value 1 and the actual position value 2.

The master axis position of the slave axis (P-0-0761) is transmitted to the slave drives via the EcoX bus. For the slave drives (EcoX slave), the value is written to parameter **P-0-0053, Master drive position**. If the slave drives are in a synchronous operating mode with "virtual master axis", they follow the master drive.

**Pertinent parameters**

- **S-0-0051, Position feedback 1 value**
- **S-0-0053, Position feedback 2 value**
- **P-0-0434, Internal Position command value**
- **P-0-0761, Master axis position for slave axis**
- **P-0-0762, Master axis generator, signal selection list**
- **P-0-0763, Master axis generator, signal selection list**
- **P-0-0768, Master axis generator, status**

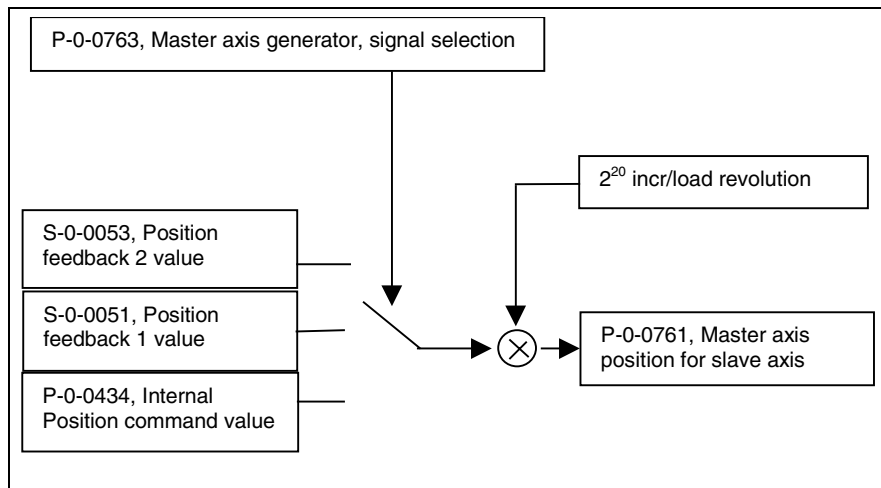

Fig. 3-20: Master axis of master drive

The list of assignable parameters contains all the parameters that can serve as the input values for the master axis generator. The parameter number that generates the input value for the master axis has to be entered in parameter **P-0-0763, Master axis generator, signal selection**.

## Virtual Master Axis Generator

**Operating mode:** Synchronous operating mode with "virtual master axis"

### Functional principle:

In the case of a virtual master axis generator, the master axis position is not derived from the position of an encoder or real drive, but determined by means of calculation. When the enable signal is set, the virtual master axis generator integrates the acceleration limit value until the velocity limit value has been reached. The current velocity is integrated, the result is the master axis position for the slave axis (P-0-0761). When the enable signal has been cleared, the velocity is decelerated to zero with the delay limit value.

### Pertinent parameters:

- **P-0-0760, Master axis generator, command word**
- **P-0-0761, Master axis position for slave axis**
- **P-0-0765, Range of master encoder**
- **P-0-0768, Master axis generator, status**
- **P-0-0770 Master axis generator, velocity limit**
- **P-0-0771, Master axis generator, acceleration limit**
- **P-0-0772 Master axis generator, deceleration**
- **P-0-0773, Master axis generator, preset position**

### 3.9 EcoX – Expansion Interface for Digital Drives

#### Overview

EcoX is the name of an expansion interface for digital drives. It is a serial, cyclic bus that allows the following functions:

- synchronization of drives and I/O modules
- connection of up to 2 modules with 16 digital inputs and outputs each per drive controller
- transmission of a command value to other drive controllers

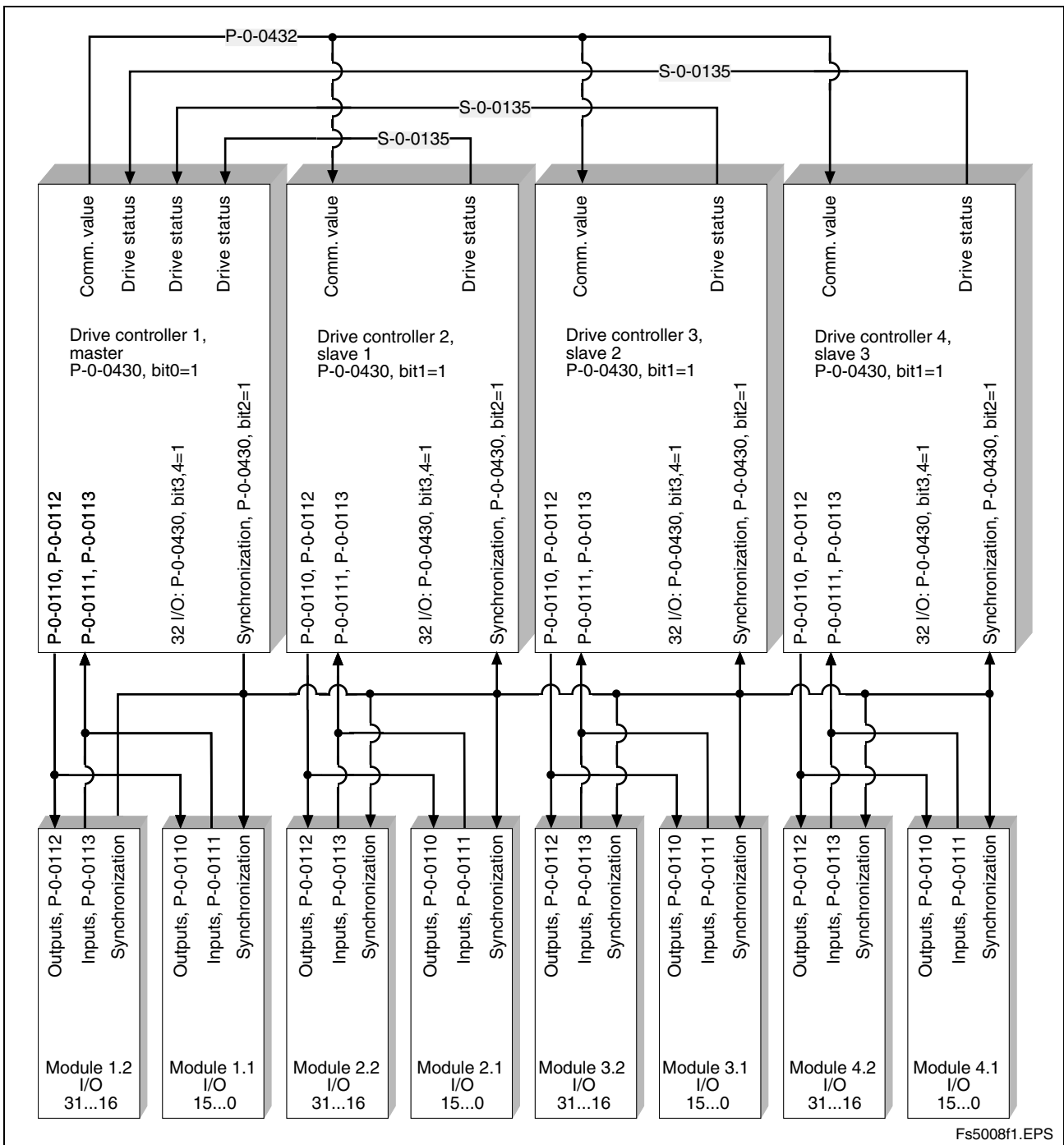

Fig. 3-21: Possible structure of an EcoX bus

## Command Value Linkage

Command value linkage of up to 20 drives. The parameter to be transmitted is specified in parameter **P-0-0432, EcoX command value, configuration**.

The following parameters can be transmitted:

- **S-0-0036, Velocity command value**
- **S-0-0040, Velocity feedback value**
- **S-0-0080, Torque/Force command**
- **S-0-0084, Torque/force feedback value**
- **P-0-0434, Internal Position command value**
- **P-0-0761, Master axis position for slave axis**
- Position command value linkage to operate Gantry axes: The master drive can be used in the positioning mode. The generated position command value is transmitted to the slave drive. The slave drive is operated in cyclic position control.
- Torque linkage: Master-slave operation of several drives. The torque command value (S-0-0080) is transmitted. The slave drive is operated in torque control.
- Speed command value linkage: The speed command value of the motor axis is transmitted to the slave. The slave drive is operated in velocity control.

## I/O Extension

It is possible to activate one (16 inputs, 16 outputs) or two (32 inputs, 32 outputs) Indramat I/O modules per drive. Use parameter **P-0-0430, EcoX configuration** for selection.

The input data are written to parameters

- **P-0-0111, Parallel input 2 and**
- **P-0-0113, Parallel input 3.**

The outputs are written by the parameters

- **P-0-0110, Parallel output 2 and**
- **P-0-0112, Parallel output 3.**

The input parameter can be assigned to any parameter which can be configured in the MDT. Any parameter which can be configured in the AT can be written to the output parameter. The cycle time of the I/O modules depends on the number of controllers at the bus, but is independent of whether 16 or 32 I/Os have been connected.

**As a matter of principle, the following applies:**

- cycle time = 1 ms \* (master + number of slaves)
- input/output delay = 1 ms

## 3.10 DISC Drive Macros

By means of program libraries available in the commissioning tool (e. g. DriveTop) or in the higher-level control unit, function macros can be loaded to the drive. Special functions that are not "hard wired" in the drive firmware are integrated in the standard firmware by means of DISC drive macros.

The following functional extensions have already been realized with DISC drive macros:

- More variable error reactions (relative and absolute return motion)
- Quick stop when signal at probe input
- Extension of existing operating modes (positioning block mode with delay time, ...)
- Automatic drive reactions when an event occurs
- Higher-level process controllers (register controllers, ...)
- Quick stop when signal at digital input
- Relative limit switch



## 4 New Fields of Application

### EcoX

#### Gantry Axis

A Gantry axis can be realized by linking a min. of 2 axes via the EcoX digital expansion interface. This allows using the Gantry axis function for "non-SERCOS drives", too.

#### Linkage of Several Axes (Master Axis Interconnection)

From the position selected via parameter **P-0-0763, Master axis generator, signal selection**, the master axis generates a master axis position for slave axes. The following slaves synchronize to this position.

#### Master-Slave Solution

Advantageous solution can be realized, because, owing to the synchronization via EcoX, there won't be any quantization effects and beat effects.

### DISC Drive Macros

#### More Variable Error Reactions

DISC drive macros allow defining any error reaction, e.g. relative return motion.

#### Additional Axis-Specific Monitoring Functions

In addition, the DISC functionality allows you defining your own monitoring functions, e.g. current or torque monitors.

#### Technology Functions

The manufacturer offers a certain number of predefined technology functions that significantly enhance the functional range of the drive. At present, the following technology functions are made available:

- "flying shears"
- register controller
- In-Feed

#### Automatic (Event-Controlled) Drive Reactions

It is also possible to interrupt the active operating mode (e.g. cam mode or phase synchronization), in order to carry out, after a selectable event, a drive reaction that has been programmed in the DISC macro.

#### Extension of Existing Operating Modes

It is also possible to extend existing operating modes or make them more flexible. There are, for example, the following options:

- positioning block mode with delay time
- relative limit switch
- "Teach\_In" function for positioning block mode
- force control

## Master Axis Generator

### Stand-Alone Drive for Cam Function

By means of the virtual master axis generator it is now possible for the drive to travel any curve shape (e.g. sine curve). This allows predefining any jerk curve (e.g. "AntiSwapp curves").

### Linkage of Several Axes (Master Axis Interconnection)

The master axis position required for linking several axes can be generated by means of the master axis generator in a drive called "master axis". The reference position for generating the master axis position is selected by means of the parameter **P-0-0763, Master axis generator, signal selection**.

### Real Master Axis Linkage

Real master axis linkage is the basic interconnection of axes via EcoX, the master axis position being generated by a real master axis encoder.

## Measuring Wheel Mode

The "measuring wheel mode" function is used with material feed axes (e. g. in sheet-metal machining). By means of a measuring wheel encoder mounted to the material, highly precise material machining is ensured even if some slip occurs between the driving motor and the material itself.

## 5 Functional Changes with Regard to the Previous Version

### 5.1 Incompatible Functional Changes

#### SSI Emulation

The output format (resp. the display range) was changed from  $\pm 2048$  revolutions to 0...4096 revolutions, because it is this kind of display that is generally used in the world of control systems.

### 5.2 Functions No Longer Available

#### As Regards "Master Communication Parallel Interface"

The stepper motor interface is no longer available.

#### As Regards "Relative Drive-Internal Interpolation"

This operating mode does no longer exist. This functionality can be performed completely and compatibly by the operating mode "Drive-controlled positioning".

#### As Regards "Error Reactions"

The error reaction "Return motion" can no longer be configured in parameter **P-0-0119, Best possible deceleration**. The corresponding function is provided by a DISC drive macro.

#### As Regards "Probe Function"

Signal selection in parameter **S-0-0169, Probe control parameter** is no longer available.

The quick stop function via probe 1 is no longer available. This functionality can be realized by means of a DISC drive macro.

### 5.3 Deleted Parameters

**S-0-0236, Master drive 1 revs.**

**S-0-0237, Slave drive 1 revs.**

**S-0-0269, Parameter buffer mode**

**P-0-0096, Distance to move in error situation**

**P-0-0123, Absolute encoder buffer**

**P-0-4033, Stepper motor resolution**

**P-0-4034, Stepper motor interface mode**

**P-7-0514, Absolute encoder offset**

## 5.4 New Parameters

S-0-0000, Dummy parameter  
S-0-0264, B300 Backup working memory procedure command  
S-0-0376, Max. actual velocity difference in percent  
S-0-0377, Maximum actual velocity difference  
S-0-0386, Active position value  
S-0-0398, IDN list of configurable data in the signal status word

P-0-0110, Parallel output 2  
P-0-0111, Parallel input 2  
P-0-0112, Parallel output 3  
P-0-0113, Parallel input 3  
P-0-0125, Assignment digital input -> IDN  
P-0-0224, Probe, number of marker failures  
P-0-0225, Probe, IDN list signal selection  
P-0-0226, Probe, extended control word  
P-0-0350, DISC - Control word  
P-0-0351, DISC - Status word  
P-0-0352, DISC - Program Logic task  
P-0-0353, DISC - Program Drive task  
P-0-0354, DISC - Program Event task  
P-0-0355, DISC - Register Logic task  
P-0-0356, DISC - Register Drive task  
P-0-0430, EcoX Configuration  
P-0-0431, EcoX command, IDN list of configurable parameters in master  
P-0-0432, EcoX command value, configuration  
P-0-0433, EcoX command, IDN list of configurable parameters in slave  
P-0-0434, Internal Position command value  
P-0-0435, List of configurable data dig. Input  
P-0-0436, List of configurable data dig. Output  
P-0-0437, List of EcoX slave drives  
P-0-0507, Optimized commutation offset  
P-0-0603, Position switch, control word  
P-0-0612, Setting absolute measurement, control word  
P-0-0750, Master axis revolutions per master axis cycle  
P-0-0751, Synchronization divisions per command cycle slave axis  
P-0-0752, Load revolutions per actual value cycle slave axis  
P-0-0753, Position actual value in actual value cycle  
P-0-0754, Command value cycle  
P-0-0755, Gear reduction  
P-0-0760, Master axis generator, command word  
P-0-0761, Master axis position for slave axis  
P-0-0762, Master axis generator, signal selection list

**P-0-0763, Master axis generator, signal selection**  
**P-0-0764, Master axis Velocity**  
**P-0-0765, Range of master encoder**  
**P-0-0766, Master encoder, monitoring window**  
**P-0-0768, Master axis generator, status**  
**P-0-0770, Master axis generator, velocity limit**  
**P-0-0771, Master axis generator, acceleration limit**  
**P-0-0772, Master axis generator, deceleration**  
**P-0-0773, Master axis generator, preset position**  
**P-7-4014, Motor type**

## 5.5 Modified Parameters

### **S-0-0040, Velocity feedback value**

- If required, the value displayed in the parameter can be filtered with  $T = 8$  ms (activated with P-0-0538, bit 7)

### **S-0-0084, Torque/Force feedback value**

- If required, the value displayed in the parameter can be filtered with  $T = 2$  ms (activated with P-0-0538, bit 7)

### **S-0-0169, Probe control parameter**

- Bit 4 is no longer available, selection by means of parameter **P-0-0200, Signal select probe 1** or parameter **P-0-0201, Signal select probe 2**
- Bit 7 quick stop is no longer available

### **S-0-0282, Positioning command value**

- In the operating mode "Drive-controlled positioning", this parameter, depending on parameter **S-0-0393, Command value mode**, acts both as the relative travel distance and as the absolute target position (cf. S-0-0258)

### **S-0-0393, Command value mode**

- Bit 3: positioning command value is processed in relative or absolute form
- Bit 4: acceptance of the new positioning command value after having reached the current target position

### **S-0-0399, IDN list of configurable data in the signal control word**

- Selection list was extended

### **P-0-0117, NC reaction on error**

- Bit 2: immediate reaction of the event task (DISC drive macro)

### **P-0-0119, Best possible deceleration**

- return motion impossible

**P-0-0155, Synchronization mode**

- Bits 2 to 4: synchronization range
- Bit 5: acceleration limit in the case of velocity synchronization

**P-0-0200, Signal select probe 1**

- Input of an IDN required; time measurement via bit in parameter **P-0-0226, Probe, extended control word**

**P-0-0201, Signal select probe 2**

- Input of an IDN required; time measurement only possible with channel 1

**P-0-0538, Motor function parameter 1**

- Bits 4 and 5: automatic commutation setting
- Bit 13: When the torque limit value is reached, the best possible deceleration is immediately initiated.

The following parameters are incremented as soon as a valid probe event occurs:

- **S-0-0409, Probe 1 positive latched**
- **S-0-0410, Probe 1 negative latched**
- **S-0-0411, Probe 2 positive latched**
- **S-0-0412, Probe 2 negative latched**

Further bits were added to the following parameters:

- **P-0-0538, Motor function parameter 1**
- **S-0-0135, Drive status word**
- **S-0-0147, Homing parameter**
- **S-0-0169, Probe control parameter**
- **S-0-0393, Command value mode**

## 6 Index

### A

absolute encoder emulation 3-31  
analog inputs 3-27  
analog interface 3-2  
analog output 3-27  
automatic commutation setting 3-31  
automatic controller setting 3-31

### B

backup working memory procedure 3-30  
basic operating modes 3-3  
baud rate 2-2

### C

command value linkage 3-35  
commutation setting, automatic 3-31  
controller setting, automatic 3-31  
controller structure 3-21

### D

deleted parameters 5-1  
detecting the marker position 3-29  
diagnostic system 3-26  
digital inputs/outputs 3-31  
DISC drive macros 3-36  
display formats 3-26  
Dolfi 2-2  
drive controllers 1-2  
drive halt 3-27  
drive macros 3-36  
drive-controlled positioning 3-7  
drive-internal interpolation 3-6

### E

EcoX 3-34  
    command value linkage 3-35  
    I/O extension 3-35  
    overview 3-34  
electronic cam shaft with real master axis 3-19  
electronic cam shaft with virtual master axis 3-13  
error reactions 3-26

### F

fields of application 4-1  
firmware types 1-1  
functional changes 5-1  
functional changes, incompatible 5-1  
functions no longer available 5-1

### I

I/O extension 3-35  
incremental encoder emulation 3-30  
inputs/outputs, digital 3-31  
interfaces (overview) 1-2

**J**

jogging 3-9

**L**

language selection 3-27  
limit switch, programmable 3-30

**M**

master axis  
  of master drive 3-32  
master axis generator, virtual 3-33  
master axis of master axis encoder 3-32  
master communication interfaces 3-1  
measuring system  
  absolute 3-24  
  motor encoder 3-23  
  optional 3-23  
measuring systems 3-23  
measuring wheel mode 3-29  
modified parameters 5-3  
motor encoder 3-23  
motor holding brake 3-22  
motor types 3-22

**O**

operating modes (overview) 1-2  
oscilloscope function 3-27

**P**

parallel interface 3-1  
parameterization 3-26  
parking axis 3-29  
phase synchronization with real master axis 3-17  
phase synchronization with virtual master axis 3-11  
position control 3-5  
position reference for actual values 3-25  
positioning block mode 3-8  
probe function 3-28  
programmable limit switch 3-30

**R**

release notes 1-1  
replacing the firmware  
  firmware replacement procedure 2-2  
  notes on how to replace the firmware 2-1

**S**

SERCOS interface 3-1  
summary of the firmware 3-1

**T**

torque/force control 3-3

**V**

velocity control 3-4  
velocity synchronization with real master axis 3-15  
velocity synchronization with virtual master axis 3-10



## 7 Service & Support

### 7.1 Helpdesk

Unser Kundendienst-Helpdesk im Hauptwerk Lohr am Main steht Ihnen mit Rat und Tat zur Seite. Sie erreichen uns

- telefonisch: **+49 (0) 9352 40 50 60**  
über Service Call Entry Center Mo-Fr 07:00-18:00
- per Fax: **+49 (0) 9352 40 49 41**
- per e-Mail: **service@indramat.de**

Our service helpdesk at our headquarters in Lohr am Main, Germany can assist you in all kinds of inquiries. Contact us

- by phone: **+49 (0) 9352 40 50 60**  
via Service Call Entry Center Mo-Fr 7:00 am - 6:00 pm
- by fax: **+49 (0) 9352 40 49 41**
- by e-mail: **service@indramat.de**

### 7.2 Service-Hotline

Außerhalb der Helpdesk-Zeiten ist der Service direkt ansprechbar unter

oder **+49 (0) 171 333 88 26**  
**+49 (0) 172 660 04 06**

After helpdesk hours, contact our service department directly at

or **+49 (0) 171 333 88 26**  
**+49 (0) 172 660 04 06**

### 7.3 Internet

Unter [www.indramat.de](http://www.indramat.de) finden Sie ergänzende Hinweise zu Service, Reparatur und Training sowie die **aktuellen** Adressen \*) unserer auf den folgenden Seiten aufgeführten Vertriebs- und Servicebüros.

- Verkaufsniederlassungen
- Niederlassungen mit Kundendienst

Außerhalb Deutschlands nehmen Sie bitte zuerst Kontakt mit unserem für Sie nächstgelegenen Ansprechpartner auf.

\*) <http://www.indramat.de/de/kontakt/adressen>  
Die Angaben in der vorliegenden Dokumentation können seit Drucklegung überholt sein.

At [www.indramat.de](http://www.indramat.de) you may find additional notes about service, repairs and training in the Internet, as well as the **actual** addresses \*) of our sales- and service facilities figuring on the following pages.

- sales agencies
- offices providing service

Please contact our sales / service office in your area first.

\*) <http://www.indramat.de/en/kontakt/adressen>  
Data in the present documentation may have become obsolete since printing.

### 7.4 Vor der Kontaktaufnahme... - Before contacting us...

Wir können Ihnen schnell und effizient helfen wenn Sie folgende Informationen bereithalten:

1. detaillierte Beschreibung der Störung und der Umstände.
2. Angaben auf dem Typenschild der betreffenden Produkte, insbesondere Typenschlüssel und Seriennummern.
3. Tel./Faxnummern und e-Mail-Adresse, unter denen Sie für Rückfragen zu erreichen sind.

For quick and efficient help, please have the following information ready:

1. Detailed description of the failure and circumstances.
2. Information on the type plate of the affected products, especially type codes and serial numbers.
3. Your phone/fax numbers and e-mail address, so we can contact you in case of questions.

## 7.5 Kundenbetreuungsstellen - Sales & Service Facilities

### Deutschland – Germany

vom Ausland: (0) nach Landeskennziffer weglassen!  
from abroad: don't dial (0) after country code!

Vertriebsgebiet Mitte Germany Centre  Rexroth Indramat GmbH Bgm.-Dr.-Nebel-Str. 2 / Postf. 1357 97816 Lohr am Main / 97803 Lohr <b>Kompetenz-Zentrum Europa</b>  Tel.: +49 (0)9352 40-0 Fax: +49 (0)9352 40-4885	<b>SERVICE</b>  <b>CALL ENTRY CENTER</b> <b>MO – FR</b> <b>von 07:00 - 18:00 Uhr</b>  <b>from 7 am – 6 pm</b>  <b>Tel. +49 (0) 9352 40 50 60</b> <a href="mailto:service@indramat.de">service@indramat.de</a>	<b>SERVICE</b>  <b>HOTLINE</b> <b>MO – FR</b> <b>von 17:00 - 07:00 Uhr</b> <b>from 5 pm - 7 am</b> + SA / SO  <b>Tel.: +49 (0)172 660 04 06</b> <b>oder / or</b> <b>Tel.: +49 (0)171 333 88 26</b>	<b>SERVICE</b>  <b>ERSATZTEILE / SPARES</b> verlängerte Ansprechzeit - extended office time - ♦ nur an Werktagen - only on working days - ♦ von 07:00 - 18:00 Uhr - from 7 am - 6 pm - <b>Tel. +49 (0) 9352 40 42 22</b>
Vertriebsgebiet Süd Germany South  Rexroth Indramat GmbH Landshuter Allee 8-10 80637 München  Tel.: +49 (0)89 127 14-0 Fax: +49 (0)89 127 14-490	Gebiet Südwest Germany South-West  Bosch Rexroth AG Vertrieb Deutschland – VD-BI Geschäftsbereich Rexroth Indramat Regionalzentrum Südwest Ringstrasse 70 / Postfach 1144 70736 Fellbach / 70701 Fellbach  Tel.: +49 (0)711 57 61-100 Fax: +49 (0)711 57 61-125	Vertriebsgebiet Ost Germany East  Bosch Rexroth AG Beckerstraße 31 09120 Chemnitz  Tel.: +49 (0)371 35 55-0 Fax: +49 (0)371 35 55-333	Vertriebsgebiet Ost Germany East  Bosch Rexroth AG Regionalzentrum Ost Walter-Köhn-Str. 4d 04356 Leipzig  Tel.: +49 (0)341 25 61-0 Fax: +49 (0)341 25 61-111
Vertriebsgebiet West Germany West  Bosch Rexroth AG Vertrieb Deutschland Regionalzentrum West Borsigstrasse 15 40880 Ratingen  Tel.: +49 (0)2102 409-0 Fax: +49 (0)2102 409-406	Vertriebsgebiet Mitte Germany Centre  Bosch Rexroth AG Regionalzentrum Mitte Waldecker Straße 13 64546 Mörfelden-Walldorf  Tel.: +49 (0) 61 05 702-3 Fax: +49 (0) 61 05 702-444	Vertriebsgebiet Nord Germany North  Bosch Rexroth AG Walsroder Str. 93 30853 Langenhagen  Tel.: +49 (0) 511 72 66 57-0 Fax: +49 (0) 511 72 66 57-95	Vertriebsgebiet Nord Germany North  Bosch Rexroth AG Kieler Straße 212 22525 Hamburg  Tel.: +49 (0) 40 81 955 966 Fax: +49 (0) 40 85 418 978

## Europa (West) - Europe (West)

**vom Ausland:** (0) nach Landeskennziffer weglassen, **Italien:** 0 nach Landeskennziffer mitwählen  
**from abroad:** don't dial (0) after country code, **Italy:** dial 0 after country code

<p>Austria - Österreich</p> <p>Bosch Rexroth GmbH Bereich Indramat Stachegasse 13 1120 Wien</p> <p>Tel.: +43 (0)1 985 25 40 Fax: +43 (0)1 985 25 40-93</p>	<p>Austria – Österreich</p> <p>Bosch Rexroth G.m.b.H. Gesch.ber. Rexroth Indramat Industriepark 18 4061 Pasching</p> <p>Tel.: +43 (0)7221 605-0 Fax: +43 (0)7221 605-21</p>	<p>Belgium - Belgien</p> <p>Bosch Rexroth AG Electric Drives &amp; Controls Industrielaan 8 1740 Ternat</p> <p>Tel.: +32 (0)2 5830719 - service: +32 (0)2 5830717 Fax: +32 (0)2 5830731 <a href="mailto:indramat@boschrexroth.be">indramat@boschrexroth.be</a></p>	<p>Denmark - Dänemark</p> <p>BEC A/S Zinkvej 6 8900 Randers</p> <p>Tel.: +45 (0)87 11 90 60 Fax: +45 (0)87 11 90 61</p>
<p>Great Britain – Großbritannien</p> <p>Bosch Rexroth Ltd. Rexroth Indramat Division Broadway Lane, South Cerney Cirencester, Glos GL7 5UH</p> <p>Tel.: +44 (0)1285 863000 Fax: +44 (0)1285 863030 <a href="mailto:sales@boschrexroth.co.uk">sales@boschrexroth.co.uk</a> <a href="mailto:service@boschrexroth.co.uk">service@boschrexroth.co.uk</a></p>	<p>Finland - Finnland</p> <p>Bosch Rexroth Oy Rexroth Indramat division Ansatie 6 017 40 Vantaa</p> <p>Tel.: +358 (0)9 84 91-11 Fax: +358 (0)9 84 91-13 60</p>	<p>France - Frankreich</p> <p>Bosch Rexroth S.A. Division Rexroth Indramat Avenue de la Trentaine BP. 74 77503 Chelles Cedex</p> <p>Tel.: +33 (0)164 72-70 00 Fax: +33 (0)164 72-63 00 <b>Hotline:</b> +33 (0)608 33 43 28</p>	<p>France - Frankreich</p> <p>Bosch Rexroth S.A. Division Rexroth Indramat 1270, Avenue de Lardenne 31100 Toulouse</p> <p>Tel.: +33 (0)5 61 49 95 19 Fax: +33 (0)5 61 31 00 41</p>
<p>France - Frankreich</p> <p>Bosch Rexroth S.A. Division Rexroth Indramat 91, Bd. Irène Joliot-Curie 69634 Vénissieux – Cedex</p> <p>Tel.: +33 (0)4 78 78 53 65 Fax: +33 (0)4 78 78 53 62</p>	<p>Italy - Italien</p> <p>Bosch Rexroth S.p.A. Via G. Di Vittoria, 1 20063 Cernusco S/N.MI</p> <p>Tel.: +39 02 2 365 270 Fax: +39 02 700 408 252378</p>	<p>Italy - Italien</p> <p>Bosch Rexroth S.p.A. Via Paolo Veronesi, 250 10148 Torino</p> <p>Tel.: +39 011 224 88 11 Fax: +39 011 224 88 30</p>	<p>Italy - Italien</p> <p>Bosch Rexroth S.p.A. Via del Progresso, 16 (Zona Ind.) 35020 Padova</p> <p>Tel.: +39 049 8 70 13 70 Fax: +39 049 8 70 13 77</p>
<p>Italy - Italien</p> <p>Bosch Rexroth S.p.A. Via Mascia, 1 80053 Castellammare di Stabia NA</p> <p>Tel.: +39 081 8 71 57 00 Fax: +39 081 8 71 68 85</p>	<p>Italy - Italien</p> <p>Bosch Rexroth S.p.A. Viale Oriani, 38/A 40137 Bologna</p> <p>Tel.: +39 051 34 14 14 Fax: +39 051 34 14 22</p>	<p>Netherlands – Niederlande/Holland</p> <p>Bosch Rexroth B.V. Kruisbroeksestraat 1 (P.O. Box 32) 5281 RV Boxtel</p> <p>Tel.: +31 (0)411 65 19 51 Fax: +31 (0)411 65 14 83 <a href="mailto:indramat@hydraudyne.nl">indramat@hydraudyne.nl</a></p>	<p>Netherlands - Niederlande/Holland</p> <p>Bosch Rexroth Services B.V. Kruisbroeksestraat 1 (P.O. Box 32) 5281 RV Boxtel</p> <p>Tel.: +31 (0)411 65 19 51 Fax: +31 (0)411 67 78 14</p>
<p>Norway - Norwegen</p> <p>Bosch Rexroth AS Rexroth Indramat Division Berghagan 1 or: Box 3007 1405 Ski-Langhus 1402 Ski</p> <p>Tel.: +47 (0)64 86 41 00 Fax: +47 (0)64 86 90 62 <a href="mailto:jul.ruud@rexroth.no">jul.ruud@rexroth.no</a></p>	<p>Spain - Spanien</p> <p>Bosch Rexroth S.A. Divisiòn Rexroth Indramat Centro Industrial Santiga Obradors s/n 08130 Santa Perpetua de Mogoda Barcelona</p> <p>Tel.: +34 9 37 47 94 00 Fax: +34 9 37 47 94 01</p>	<p>Spain – Spanien</p> <p>Goimendi S.A. Divisiòn Rexroth Indramat Parque Empresarial Zuatzu C/ Francisco Grandmontagne no.2 20018 San Sebastian</p> <p>Tel.: +34 9 43 31 84 21 - service: +34 9 43 31 84 56 Fax: +34 9 43 31 84 27 - service: +34 9 43 31 84 60 <a href="mailto:sat.indramat@goimendi.es">sat.indramat@goimendi.es</a></p>	<p>Sweden - Schweden</p> <p>Rexroth Mecman Svenska AB Rexroth Indramat Division - Varuvägen 7 (Service: Konsumentvägen 4, Älfsjö) 125 81 Stockholm</p> <p>Tel.: +46 (0)8 727 92 00 Fax: +46 (0)8 647 32 77</p>
<p>Sweden - Schweden</p> <p>Rexroth Mecman Svenska AB Indramat Support Ekvåndan 7 254 67 Helsingborg</p> <p>Tel.: +46 (0) 42 38 88 -50 Fax: +46 (0) 42 38 88 -74</p>	<p>Switzerland West - Schweiz West</p> <p>Bosch Rexroth Suisse SA Département Rexroth Indramat Rue du village 1 1020 Renens</p> <p>Tel.: +41 (0)21 632 84 20 Fax: +41 (0)21 632 84 21</p>	<p>Switzerland East - Schweiz Ost</p> <p>Bosch Rexroth Schweiz AG Geschäftsbereich Indramat Hemrietstrasse 2 8863 Buttikon</p> <p>Tel. +41 (0) 55 46 46 111 Fax +41 (0) 55 46 46 222</p>	

## Europa (Ost) - Europe (East)

**vom Ausland:** (0) nach Landeskennziffer weglassen  
**from abroad:** don't dial (0) after country code

Czech Republic - Tschechien Bosch -Rexroth, spol.s.r.o. Hviezdoslavova 5 627 00 Brno Tel.: +420 (0)5 48 126 358 Fax: +420 (0)5 48 126 112	Czech Republic - Tschechien DEL a.s. Strojirenská 38 591 01 Zdar nad Sázavou Tel.: +420 616 64 3144 Fax: +420 616 216 57	Hungary - Ungarn Bosch Rexroth Kft. Angol utca 34 1149 Budapest Tel.: +36 (1) 364 00 02 Fax: +36 (1) 383 19 80	Poland – Polen Bosch Rexroth Sp.zo.o. ul. Staszica 1 05-800 Pruszków Tel.: +48 22 738 18 00 – service: +48 22 738 18 46 Fax: +48 22 758 87 35 – service: +48 22 738 18 42
Poland – Polen Bosch Rexroth Sp.zo.o. Biuro Poznan ul. Dabrowskiego 81/85 60-529 Poznan Tel.: +48 061 847 64 62 /-63 Fax: +48 061 847 64 02	Rumania - Rumänien Bosch Rexroth Sp.zo.o. Str. Drobety nr. 4-10, app. 14 70258 Bucuresti, Sector 2 Tel.: +40 (0)1 210 48 25 +40 (0)1 210 29 50 Fax: +40 (0)1 210 29 52	Russia - Russland Bosch Rexroth Wjatskaja ul. 27/15 125015 Moskau Tel.: +7-095-785 74 78 +7-095 785 74 79 Fax: +7 095 785 74 77 <a href="mailto:info.rex@boschrexroth.ru">info.rex@boschrexroth.ru</a>	Russia - Russland ELMIS 10, Internationalnaya Str. 246640 Gomel, Belarus Tel.: +375/ 232 53 42 70 Fax: +375/ 232 53 37 69 <a href="mailto:elmis_ltd@yahoo.com">elmis_ltd@yahoo.com</a>
Turkey - Türkei Bosch Rexroth Otomasyon San & Tic. A..S. Fevzi Cakmak Cad No. 3 34630 Sefaköy Istanbul Tel.: +90 212 541 60 70 Fax: +90 212 599 34 07	Slowenia - Slowenien DOMEL Otoki 21 64 228 Zelezniki Tel.: +386 5 5117 152 Fax: +386 5 5117 225 <a href="mailto:brane.ozebek@domel.si">brane.ozebek@domel.si</a>		

## Africa, Asia, Australia – incl. Pacific Rim

**vom Ausland:** (0) nach Landeskennziffer weglassen!  
**from abroad:** don't dial (0) after country code!

<p>Australia - Australien</p> <p>AIMS - Australian Industrial Machinery Services Pty. Ltd. Unit 3/45 Horne ST Campbellfield , VIC 3061 Melbourne Tel.: +61 (0) 393 590 228 Fax: +61 (0) 393 590 286 Hotline: +61 (0) 419 369 195 <a href="mailto:terryobrien@aimsservices.com.au">terryobrien@aimsservices.com.au</a></p>	<p>Australia - Australien</p> <p>Bosch Rexroth Pty. Ltd. No. 7, Endeavour Way Braeside Victoria, 31 95 Melbourne Tel.: +61 (0)3 95 80 39 33 Fax: +61 (0)3 95 80 17 33 <a href="mailto:mel@rexroth.com.au">mel@rexroth.com.au</a></p>	<p>China</p> <p>Shanghai Bosch Rexroth Hydraulics &amp; Automation Ltd. Wai Gao Qiao Free Trade Zone No.122, Fu Te Dong Yi Road Shanghai 200131 - P.R.China Tel.: +86 21 58 66 30 30 Fax: +86 21 58 66 55 23 <a href="mailto:roger.shi_sh@boschrexroth.com.cn">roger.shi_sh@boschrexroth.com.cn</a></p>	<p>China</p> <p>Bosch Rexroth (China) Ltd. 15/F China World Trade Center 1, Jianguomenwai Avenue Beijing 100004, P.R.China Tel.: +86 10 65 05 03 80 Fax: +86 10 65 05 03 79</p>
<p>China</p> <p>Bosch Rexroth (China) Ltd. A-5F., 123 Lian Shan Street Sha He Kou District Dalian 116 023, P.R.China Tel.: +86 411 46 78 930 Fax: +86 411 46 78 932</p>	<p>China</p> <p>Bosch Rexroth (Changzhou) Co.Ltd. Guangzhou Repres. Office Room 1014-1016, Metro Plaza, Tian He District, 183 Tian He Bei Rd Guangzhou 510075, P.R.China Tel.: +86 20 8755-0030 +86 20 8755-0011 Fax: +86 20 8755-2387</p>	<p>Hongkong</p> <p>Bosch Rexroth (China) Ltd. 6<sup>th</sup> Floor, Yeung Yiu Chung No.6 Ind Bldg. 19 Cheung Shun Street Cheung Sha Wan, Kowloon, Hongkong Tel.: +852 22 62 51 00 Fax: +852 27 41 33 44 <a href="mailto:alexis.siu@boschrexroth.com.hk">alexis.siu@boschrexroth.com.hk</a></p>	<p>India - Indien</p> <p>Bosch Rexroth (India) Ltd. Rexroth Indramat Division Plot. A-58, TTC Industrial Area Thane Turbhe Midc Road Mahape Village Navi Mumbai - 400 701 Tel.: +91 (0)22 7 61 46 22 Fax: +91 (0)22 7 68 15 31</p>
<p>India - Indien</p> <p>Bosch Rexroth (India) Ltd. Rexroth Indramat Division Plot. 96, Phase III Peenya Industrial Area Bangalore - 560058 Tel.: +91 (0)80 8 39 73 74 Fax: +91 (0)80 8 39 43 45</p>	<p>Indonesia - Indonesien</p> <p>PT. Rexroth Wijayakusuma Building # 202, Cilandak Commercial Estate Jl. Cilandak KKO, Jakarta 12560 Tel.: +62 21 7891169 (5 lines) Fax: +62 21 7891170 - 71</p>	<p>Japan</p> <p>Bosch Rexroth Automation Corp. Service Center Japan Yutakagaoka 1810, Meito-ku, NAGOYA 465-0035, Japan Tel.: +81 (0)52 777 88 41 +81 (0)52 777 88 53 +81 (0)52 777 88 79 Fax: +81 (0)52 777 89 01</p>	<p>Japan</p> <p>Bosch Rexroth Automation Corp. Rexroth Indramat Division 1F, I.R. Building Nakamachidai 4-26-44, Tsuzuki-ku YOKOHAMA 224-0041, Japan Tel.: +81 (0)45 942 72 10 Fax: +81 (0)45 942 03 41</p>
<p>Korea</p> <p>Bosch Rexroth-Korea Ltd. 1515-14 Dadae-Dong, Saha-Ku Rexroth Indramat Division Pusan Metropolitan City, 604-050 Republic of South Korea Tel.: +82 (0)51 26 00 741 Fax: +82 (0)51 26 00 747 <a href="mailto:gyhan@rexrothkorea.co.kr">gyhan@rexrothkorea.co.kr</a></p>	<p>Malaysia</p> <p>Bosch Rexroth Sdn.Bhd. 11, Jalan U8/82 Seksyen U8 40150 Shah Alam Selangor, Malaysia Tel.: +60 (0) 3 78 44 80 00 Fax: +60 (0) 3 78 45 48 00 <a href="mailto:hockhwa@hotmail.com">hockhwa@hotmail.com</a> <a href="mailto:rexroth1@tm.net.my">rexroth1@tm.net.my</a></p>	<p>Singapore - Singapur</p> <p>Bosch Rexroth SDN BHD. No.11, Jalan Astaka U8/82 Seksyen U8 40150 Shah Alam Selangor Darul Ehsan Tel.: +65 (0) 3 7844 8000 Fax: +65 (0) 3 7845 4800 <a href="mailto:kenton.peh@boschrexroth.com.sg">kenton.peh@boschrexroth.com.sg</a></p>	<p>South Africa - Südafrika</p> <p>TECTRA Automation (Pty) Ltd. 28 Banfield Road, Industria North Maraisburg 1700 Tel.: +27 (0)11 673 20 80 Fax: +27 (0)11 673 72 69 Hotline: +27 (0)82 903 29 23 <a href="mailto:georgv@tectra.co.za">georgv@tectra.co.za</a></p>
<p>Taiwan</p> <p>Rexroth Uchida Co., Ltd. No.17, Lane 136, Cheng Bei 1 Rd., Yungkang, Tainan Hsien Taiwan, R.O.C. Tel.: +886 (0)6 25 36 565 Fax: +886 (0)6 25 34 754 <a href="mailto:indramat@mail.net.tw">indramat@mail.net.tw</a></p>	<p>Thailand</p> <p>NC Advance Technology Co. Ltd. 59/76 Moo 9 Ramintra road 34 Tharang, Bangkhen, Bangkok 10230 Tel.: +66 2 943 70 62 +66 2 943 71 21 Fax: +66 2 509 23 62 <a href="mailto:sonkawin@hotmail.com">sonkawin@hotmail.com</a></p>		

## Nordamerika – North America

<b>USA</b> Hauptniederlassung - Headquarters  Bosch Rexroth Corporation Rexroth Indramat Division 5150 Prairie Stone Parkway Hoffman Estates, IL 60192-3707 Tel.: +1 847 6 45 36 00 Fax: +1 847 6 45 62 01 <a href="mailto:service@indramat.com">service@indramat.com</a>	<b>USA Central Region - Mitte</b>  Bosch Rexroth Corporation Rexroth Indramat Division Central Region Technical Center 1701 Harmon Road Auburn Hills, MI 48326 Tel.: +1 248 3 93 33 30 Fax: +1 248 3 93 29 06	<b>USA Southeast Region - Südwest</b>  Bosch Rexroth Corporation Rexroth Indramat Division Southeastern Technical Center 3625 Swiftwater Park Drive Suwanee, Georgia 30124 Tel.: +1 770 9 32 32 00 Fax: +1 770 9 32 19 03	<b>USA SERVICE-HOTLINE</b>  - 7 days x 24hrs -  <b>+1-800-860-1055</b>
<b>USA East Region –Ost</b>  Bosch Rexroth Corporation Rexroth Indramat Division Charlotte Regional Sales Office 14001 South Lakes Drive Charlotte, North Carolina 28273 Tel.: +1 704 5 83 97 62 +1 704 5 83 14 86	<b>USA Northeast Region – Nordost</b>  Bosch Rexroth Corporation Rexroth Indramat Division Northeastern Technical Center 99 Rainbow Road East Granby, Connecticut 06026 Tel.: +1 860 8 44 83 77 Fax: +1 860 8 44 85 95	<b>USA West Region – West</b>  Bosch Rexroth Corporation 7901 Stoneridge Drive, Suite 220 Pleasant Hill, California 94588  Tel.: +1 925 227 10 84 Fax: +1 925 227 10 81	
<b>Canada East - Kanada Ost</b>  Bosch Rexroth Canada Corporation Burlington Division 3426 Mainway Drive Burlington, Ontario Canada L7M 1A8 Tel.: +1 905 335 55 11 Fax: +1 905 335-41 84 <a href="mailto:michael.moro@boschrexroth.ca">michael.moro@boschrexroth.ca</a>	<b>Canada West - Kanada West</b>  Bosch Rexroth Canada Corporation 5345 Goring St. Burnaby, British Columbia Canada V7J 1R1 Tel.: +1 604 205-5777 Fax: +1 604 205-6944 <a href="mailto:david.gunby@boschrexroth.ca">david.gunby@boschrexroth.ca</a>	<b>Mexico</b>  Bosch Rexroth S.A. de C.V. Calle Neptuno 72 Unidad Ind. Vallejo 07700 Mexico, D.F.  Tel.: +52 5 754 17 11 +52 5 754 36 84 +52 5 754 12 60 Fax: +52 5 754 50 73 +52 5 752 59 43	<b>Mexico</b>  Bosch Rexroth S.A. de C.V. Calle Argentina No 3913 Fracc. las Torres 64930 Monterey, N.L.  Tel.: +52 8 333 88 34...36 +52 8 349 80 91...93 Fax: +52 8 346 78 71 <a href="mailto:mario.quiroga@boschrexroth.com.mx">mario.quiroga@boschrexroth.com.mx</a>

## Südamerika – South America

<b>Argentina - Argentinien</b>  Bosch Rexroth S.A.I.C. "The Drive & Control Company" Acassusso 48 41/47 1605 Munro Prov. Buenos Aires Tel.: +54 (0)11 4756 01 40 Fax: +54 (0)11 4756 01 36 <a href="mailto:victor.jabif@boschrexroth.com.ar">victor.jabif@boschrexroth.com.ar</a>	<b>Argentina - Argentinien</b>  NAKASE Servicio Tecnico CNC Calle 49, No. 5764/66 1653 Villa Balester Prov. - Buenos Aires Tel.: +54 (0) 11 4768 36 43 Fax: +54 (0) 11 4768 24 13 <a href="mailto:nakase@usa.net">nakase@usa.net</a> <a href="mailto:nakase@nakase.com">nakase@nakase.com</a>	<b>Brazil - Brasilien</b>  Bosch Rexroth Ltda. Av. Tégula, 888 Ponte Alta, Atibaia SP CEP 12942-440  Tel.: +55 (0)11 4414 56 92 +55 (0)11 4414 56 84 Fax sales: +55 (0)11 4414 57 07 Fax serv.: +55 (0)11 4414 56 86 <a href="mailto:alexandre.wittwer@rexroth.com.br">alexandre.wittwer@rexroth.com.br</a>	<b>Brazil - Brasilien</b>  Bosch Rexroth Ltda. R. Dr.Humberto Pinheiro Vieira, 100 Distrito Industrial [Caixa Postal 1273] 89220-390 Joinville - SC  Tel./Fax: +55 (0)47 473 58 33 Mobil: +55 (0)47 9974 6645 <a href="mailto:prochnow@zaz.com.br">prochnow@zaz.com.br</a>
<b>Columbia - Kolumbien</b>  Reflutec de Colombia Ltda. Calle 37 No. 22-31 Santafé de Bogotá, D.C. Colombia Tel.: +57 1 368 82 67 +57 1 368 02 59 Fax: +57 1 268 97 37 <a href="mailto:reflutec@inter.net.co">reflutec@inter.net.co</a>			



---

289470

Printed in Germany